

Errata

Title & Document Type: 83623A and 83624A Synthesized Sweepers Calibration - Volume 2

Manual Part Number: 08360-90025

Revision Date: June 1990

HP References in this Manual

This manual may contain references to HP or Hewlett-Packard. Please note that Hewlett-Packard's former test and measurement, semiconductor products and chemical analysis businesses are now part of Agilent Technologies. We have made no changes to this manual copy. The HP XXXX referred to in this document is now the Agilent XXXX. For example, model number HP8648A is now model number Agilent 8648A.

About this Manual

We've added this manual to the Agilent website in an effort to help you support your product. This manual provides the best information we could find. It may be incomplete or contain dated information, and the scan quality may not be ideal. If we find a better copy in the future, we will add it to the Agilent website.

Support for Your Product

Agilent no longer sells or supports this product. You will find any other available product information on the Agilent Test & Measurement website:

www.tm.agilent.com

Search for the model number of this product, and the resulting product page will guide you to any available information. Our service centers may be able to perform calibration if no repair parts are needed, but no other support from Agilent is available.

CALIBRATION

HP 8360 SERIES SYNTHESIZED SWEEPERS

MODELS

83623A

0.01 to 20 GHz High Power

83624A

2 to 20 GHz High Power

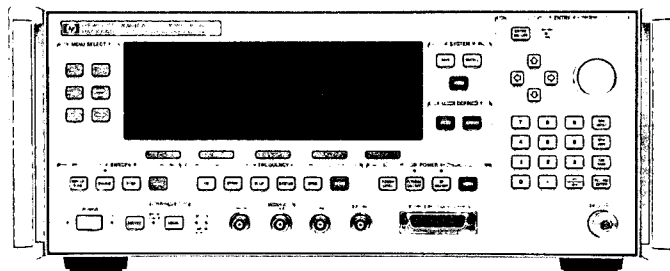

**HEWLETT
PACKARD**

**Volume 2, Calibration
HP 8360 Series Synthesized Sweepers**

Models

83623A	83624A
0.01 to 20 GHz High Power	2 to 20 GHz High Power
(Including Options 001, 003, 004, and 008)	

SERIAL NUMBERS

This manual applies directly to HP 8360 series model 83623A synthesized sweepers having serial number prefix 2931A, and model 83624A synthesized sweepers having serial number prefix 2936A.

For additional information about serial numbers, see Instruments Covered by this Manual, in the "PREFACE."

©Copyright HEWLETT-PACKARD COMPANY 1989
1400 FOUNTAINGROVE PARKWAY, SANTA ROSA, CA 95403 U.S.A.

MANUAL PART NO. 08360-90025
Microfiche Part Number 08360-90027
Part of Documentation Sets:
08360-90076
83623-90007
83624-90007

Printed: JUNE 18, 1990



**HEWLETT
PACKARD**

HP 8360 SERIES DOCUMENTATION MAP CALIBRATION MANUAL

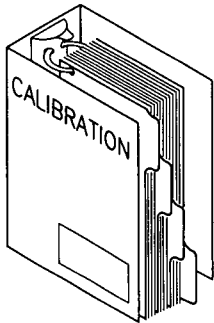

INDEX	
GLOSSARY	
5 MENUS	Menu Maps.
4 AUTOMATED TESTS	Software-Run Performance Tests and Adjustments. Front Panel Emulator Instructions.
Calibration Constants	
3 ADJUSTMENTS	Adjusting Instrument After Repair. Adjusting Instrument After Performance Test Failure.
Operation Verification	
2 PERFORMANCE TESTS	Incoming Inspection. Testing Instrument to Specifications. Testing Instrument after Repair.
1 EQUIPMENT REQUIRED	Equipment for Performance Tests. Equipment for Adjustments.
CONTENTS	
PREFACE	

MORE MAPS

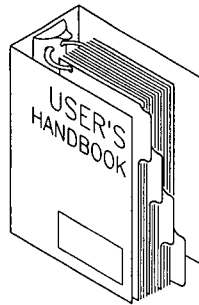

FRONT PANEL
AND
PROGRAMMING REFERENCE

**4 OPERATOR'S CHECK
ROUTINE MAINTENANCE**

Checking Instrument
Operation.
Cleaning Fan Filter.
Changing Fuses.
Cleaning the Display.

3 INSTALLATION

Unpacking the Instrument.
Option Definitions.
Compatibility.
Instrument Storage.
Packing the Instrument.
Environmental Requirements.
Fuses and Line Cords.
Accessories Supplied.
Touch-Up Paint.

**2 OPERATING & PROGRAMMING
REFERENCE**

Softkey Definitions.
Hardkey Definitions.
Error Messages.
Menu Maps.
Specifications.

1 GETTING STARTED

Front Panel Operation.
Remote Operation (Programming).
Operating and Programming Applications.
Operating and Programming Examples.

7 OPTION RETROFITS

Retrofits Available.

6 PREVENTIVE MAINTENANCE

Cleaning the Fan Filter.
Replacing a Fuse.
Cleaning the Display.

5 MENUS & SELF TESTS

Menu Maps.
Running Instrument Self Tests.

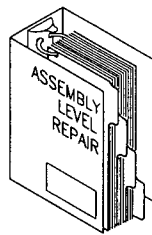

4 REPLACABLE PARTS

Assembly Part Numbers.
Hardware Part Numbers.
Documentation Part Numbers.
Module Exchange Program Information.
Instrument Touch-Up Paint.

3 POST-REPAIR

List of Adjustments After a Repair.
List of Performance Tests After a Repair.

**2 DISASSEMBLY &
REPLACEMENT PROCEDURES**

Replacing Difficult Assemblies.

1 TROUBLESHOOTING

Isolating a Faulty Assembly.

CERTIFICATION

Hewlett-Packard Company certifies that this product met its published specifications at the time of shipment from the factory. Hewlett-Packard further certifies that its calibration measurements are traceable to the United States National Institute of Standards and Technology (NIST, formerly NBS), to the extent allowed by the Institute's calibration facility, and to the calibration facilities of other International Standards Organization members.

WARRANTY

This Hewlett-Packard system product is warranted against defects in materials and workmanship for a period corresponding to the individual warranty periods of its component products. Computer and computer peripherals are warranted for a period of 90 days. Instruments are warranted for a period of one year. During the warranty period, Hewlett-Packard Company will, at its option, either repair or replace products which prove to be defective.

Warranty service for products installed by HP and certain other products designated by HP will be performed at Buyer's facility at no charge within HP service travel areas. Outside HP service travel areas, warranty service will be performed at Buyer's facility only upon HP's prior agreement and Buyer shall pay HP's round trip travel expenses. In all other areas, products must be returned to a service facility designated by HP.

For products returned to HP for warranty service, Buyer shall prepay shipping charges to HP and HP shall pay shipping charges to return the product to Buyer. However, Buyer shall pay all shipping charges, duties, and taxes for products returned to HP from another country.

HP warrants that its software and firmware designated by HP for use with an instrument will execute its programming instructions when properly installed on that instrument. HP does not warrant that the operation of the instrument, or software, or firmware will be uninterrupted or error free.

LIMITATION OF WARRANTY

The foregoing warranty shall not apply to defects resulting from improper or inadequate maintenance by Buyer, Buyer-supplied software or interfacing, unauthorized modification or misuse, operation outside of the environmental specifications for the product, or improper site preparation or maintenance.

NO OTHER WARRANTY IS EXPRESSED OR IMPLIED. HP SPECIFICALLY DISCLAIMS THE IMPLIED WARRANTIES OR MERCHANTABILITY AND FITNESS FOR A PARTICULAR PURPOSE.

EXCLUSIVE REMEDIES

THE REMEDIES PROVIDED HEREIN ARE BUYER'S SOLE AND EXCLUSIVE REMEDIES. HP SHALL NOT BE LIABLE FOR ANY DIRECT, INDIRECT, SPECIAL, INCIDENTAL, OR CONSEQUENTIAL DAMAGES, WHETHER BASED ON CONTRACT, TORT, OR ANY OTHER LEGAL THEORY.

ASSISTANCE

Product maintenance agreements and other customer assistance agreements are available for Hewlett-Packard products.

For any assistance, contact your nearest Hewlett-Packard Sales and Service Office. Addresses are provided at the back of this manual.

PREFACE

HOW TO USE THIS MANUAL

Instruments Covered by this Manual

This manual applies directly to HP 83623A and 83624A synthesized sweepers that have a serial number prefix listed on the title page (see the serial number label attached to the synthesizer's rear panel). Figure i shows a typical serial number label. A prefix (four digits followed by a letter), and a sequential suffix (five digits unique to each instrument), compose the serial number. For serial prefixes before those listed on the title page, refer to the *HP 8360 Series Synthesized Sweepers Instrument History* (to order, see "REPLACEABLE PARTS").

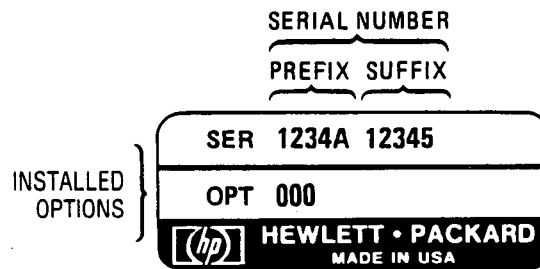

Figure i. Typical Serial Number Label

Manual Organization

Tabs divide the chapters and sections of this manual. See "CONTENTS" for a list of what each chapter and section covers. For a pictorial representation of this manual, the *User's Handbook*, and the *Assembly-Level Repair* manual, see the documentation map at the front of this manual.

Conventions

- Italics* Italic type indicates emphasis, or the title of a manual or other publication.
- Computer Computer type is used for information displayed on the synthesizer. For example: The instrument displays POWER LEVEL.
- Hardkeys** Instrument keys are in "key cap." You are instructed to *press* a hardkey.
- [Softkeys]** softkeys are just below the display, and their functions depend on the current display. These keys are in "softkey." You are instructed to *select* a softkey.

HOW TO ORDER MANUALS

A manual part number and microfiche part number are listed on the title page of this manual. Use either to order extra copies of this manual. Also listed are the documentation sets that include this manual.

Microfiche are 10 by 15 cm (4 by 6 in) microfilm transparencies. Each microfiche contains reduced photocopies of the manual pages.

See "REPLACEABLE PARTS," in the *Assembly-Level Repair* manual for a complete list of documentation and ordering numbers.

SAFETY CONSIDERATIONS

GENERAL

This product and related documentation must be reviewed for familiarization with safety markings and instructions before operation. This product has been designed and tested in accordance with international standards.

SAFETY SYMBOLS

Instruction manual symbol: the product will be marked with this symbol when it is necessary for the user to refer to the instruction manual (refer to Table of Contents).

Indicates hazardous voltages.

Indicates earth (ground) terminal.

WARNING

The WARNING sign denotes a hazard. It calls attention to a procedure, practice, or the like, which, if not correctly performed or adhered to, could result in personal injury. Do not proceed beyond a WARNING sign until the indicated conditions are fully understood and met.

CAUTION

The CAUTION sign denotes a hazard. It calls attention to an operating procedure, practice, or the like, which, if not correctly performed or adhered to, could result in damage to or destruction of part or all of the product. Do not proceed beyond a CAUTION sign until the indicated conditions are fully understood and met.

SAFETY EARTH GROUND

This is a Safety Class I product (provided with a protective earthing terminal). An uninterruptible safety earth ground must be provided from the main power source to the product input wiring terminals, power, cord, or supplied power cord set. Whenever it is likely that the protection has been impaired, the product must be made inoperative and secured against any unintended operation.

BEFORE APPLYING POWER

Verify that the product is configured to match the available main power source per the input power configuration instructions provided in this manual.

If this product is to be energized via an auto-transformer make sure the common terminal is connected to the neutral (grounded side of the mains supply).

SERVICING

WARNING

Any servicing, adjustment, maintenance, or repair of this product must be performed only by qualified personnel.

Adjustments described in this manual may be performed with power supplied to the product while protective covers are removed. Energy available at many points may, if contacted, result in personal injury.

Capacitors inside this product may still be charged even when disconnected from their power source.

To avoid a fire hazard, only fuses with the required current rating and of the specified type (normal blow, time delay, etc.) are to be used for replacement.

CONTENTS

HP 83623A AND 83624A SYNTHESIZED SWEEPERS

TABLE OF CONTENTS

SECTION 1. EQUIPMENT REQUIRED

Required Test Equipment Table	1-1
-------------------------------	-----

SECTION 2. PERFORMANCE TESTS

How to Use this Chapter	2-1
Menus	2-1
Operator's Check	2-2
Operation Verification	2-2
Automated Performance Tests	2-2
Equipment Required	2-2
Test Record	2-2
Test Sequence	2-2
Calibration Cycle	2-2
1. Internal Timebase: Aging	
Rate Test	2-5
2. Swept Frequency Accuracy Test	2-9
3. Frequency Switching Time Test	2-13
4. Power Accuracy Test	2-19
5. Power Flatness Test	2-21
6. Maximum Leveled Power Test	2-23
7. External Leveling Test	2-27
8. Spurious Signals (Harmonic) Test	2-29
9. Spurious Signals (Non-Harmonic) Test	2-33
10. Spurious Signals (Line-Related) Test	2-37
11. Single Sideband Phase Noise Test	2-41
12. Pulse Modulation On/Off Ratio Test	2-47
13. Pulse Performance Test	2-51
14. Pulse Modulation Video Feedthrough Test	2-57
15. AM Accuracy Test	2-63
16. AM Bandwidth Test	2-65
17. AM Dynamic Range Test	2-69
18. FM Accuracy Test	2-73
19. FM Bandwidth Test	2-77
20. Maximum FM Deviation Test	2-83
Test Record	2-87

OPERATION VERIFICATION

Introduction	2-95
Menus	2-95
The Operation Verification Form	2-95
1. Self-Tests	2-95
2. Power Accuracy	2-96
3. Power Flatness	2-96
4. Maximum Leveled Power	2-96
Operation Verification Form	2-97

SECTION 3. ADJUSTMENTS

How to Use this Chapter	3-1
Menus	3-1
Equipment Required	3-2
Cautions and Warnings	3-2
1. 10 MHz Standard Adjustment	3-3
2. Fractional-N VCO Adjustment	3-7
3. Fractional-N Reference and API Spurs Adjustment	3-9
4. Sweep Ramp Adjustment	3-13
5. Sampler Assembly Adjustment	3-15
6. YO Driver +10V Reference Adjustment	3-21
7. YO Driver Gain and Linearity Adjustment	3-23
8. YO Loop Gain Adjustment	3-25
9. Amplifier Detector Offset Adjustment	3-27
10. SYTM Adjustments	3-29
11. Low Power SRD Bias Adjustment	3-53
12. Amplifier Detector Gain Adjustment	3-57
13. Modulator Offset and Gain Adjustment	3-59
14. ALC Power Level Accuracy Adjustment	3-63
15. Power Flatness Adjustment	3-69
16. AM Accuracy Adjustment	3-71
17. AM Delay Adjustment	3-75
18. Pulse Delay Adjustment	3-77
19. FM Gain Adjustment	3-81
20. Square Wave Symmetry Adjustment	3-85

CALIBRATION CONSTANTS

Introduction	3-87
Definition	3-88
Memory Areas	3-88
Working Data	3-88
Protected Data	3-88
Default Data	3-88
Checksum Verification	3-89
Calibration Constant Password	3-89
Entering a Password	3-89
Disabling a Password	3-90
Setting a Password	3-90
Bypassing the Password	3-90
Changing Working Data	
Calibration Constants	3-91
Saving Working Data	
Calibration Constants	3-92
Loading Protected Data	
Calibration Constants	3-92
Loading Default Data	
Calibration Constants	3-92
Calibration Constant Descriptions	3-93
Calibration Constant	
Descriptions Table	3-94

SECTION 4. AUTOMATED TESTS

Introduction	4-1
Setting Up the System	4-2
Hardware Requirements	4-2
Operating System Requirements	4-2
Installing the Software	4-3
Disk Files	4-3
Make Working Copies	4-3

Installing Program to a Hard Disk	4-3
Operating From a Floppy Disk	4-3
Double- to Single-Sided	
Disk Conversion	4-4
Running the Software	4-5
Configuration Limitations	4-5
Loading the Performance	
Test Program	4-5
Loading Single-Sided Formatted Disks	4-6
Reporting Software Bugs	4-6
Automated Performance Tests	4-7
1. Step Attenuator Flatness Test	4-7
2. Power Flatness and Accuracy Test	4-9
Automated Adjustments	4-11
1. Step Attenuator	
Flatness Adjustment	4-11
2. YO Delay Adjustment	4-13
3. ADC Adjustment	4-13
4. Power Flatness Adjustment	4-14
Utilities	4-17
1. Front Panel Emulation	4-17
2. Calibration Constants	4-20
3. Self-Test	4-20

SECTION 5. MENUS

ALC Menu	1
Frequency Menu	2
Marker Menu	3
Modulation Menu	4
Power Menu	5
Service Menu	6
Sweep Menu	7
System Menu	8
User Cal Menu	9

1 EQUIPMENT REQUIRED

Table 1-1. Required Test Equipment (1 of 4)

Instrument	Critical Specifications	Recommended Model ¹	Use ²
Spectrum Analyzer	Output Power: > 16 V p-p into 50Ω	HP 8566B ³	P2,8,9,10,12,17,18,20 A3,19
Function Generator Local Oscillator (Synthesized Sweeper)	Frequency Range: 20 Hz to 5 MHz	HP 3325A Option 002 HP 83620/HP 8340A/B ³	P20 P13,15
Spectrum Analyzer with Tracking Generator Controller	4 Mbyte RAM BASIC 5.0 HP-IB	HP 3585A/B	P16,19
Software	No Substitute (Included in this Manual)	HP 9836/HP 9920/ HP 310/HP 320	AP1,2 AA1,2,3,4
DVM	Range: -50 to +50 VDC Accuracy: ±0.01% Input Impedance: ≥ 10 MΩ	HP P/N 08360-10001	AP1,2 AA 1,2,3,4
Digital Oscilloscope	Dual Channel Bandwidth: dc to 300 MHz Input Impedance: 1 MΩ and 50 MΩ Vertical Sensitivity: ≤5 mV/Div Horizontal Sensitivity: 50 ns/Div Trigger: Event Triggerable Division Ratio: 10:1	HP 3456A ³ HP 3457A	P7,15,19 A17,18 AA3
Oscilloscope Probes	A vs B Sweep Mode Vertical Sensitivity: 5 mV/Div Bandwidth: 100 MHz	HP 5410D/ HP 5411D ³	P1,2,3,13,14,19 A1,11,13
Analog Oscilloscope		HP 10431A HP 1740A	A10

1. A slash "/" separating the models indicates either model may be used for the tests and adjustments listed in the "Use" column. If the models are listed without slashes, then each of the models listed is recommended for use in those tests and adjustments listed directly across from the model.

2. P - Manual performance test (by test number)

A - Manual adjustment (by adjustment number)

3. Recommended model is part of the microwave test station.

AP - Automated performance test (by test number)

AA - Automated adjustment (by adjustment number)

Table 1-1. Required Test Equipment (2 of 4)

Instrument	Critical Specifications	Recommended Model ¹	Use ²
Pulse Generator	Pulse Width: ≤50 ns Rise Time: ≤10 ns Frequency: 10 Hz to 5 MHz	HP 8112B/HP 8116A ³	P13,14 A18
Function Generator	Sinewave Amplitude: ≥1V rms Sinewave Frequency: dc to 100 kHz	HP 3325A/HP 8116A ³	P15,17,18,19 A16,17,19
Frequency Standard	Frequency: 10 MHz Stability: > 1 x 10 ⁻¹⁰ /yr	HP 5061A	P1, A1
Power Meter	Power Range: 1 uW to 100 mW Accuracy: ± 0.02 dB	HP 436A HP 437A HP 438A	P4,17 A10,14,16,20 P5 A15 AP2 AA4
Power Sensor	Frequency Range: 10 MHz to 2.3 GHz Frequency Range: 50 MHz to 20 GHz Power Range: 1 uW to 100 uW	HP 8481A HP 8485A	P5 A15 AP2 AA4 P4,5,17 A10,14,15,16,20 AP2 AA4
Measuring Receiver	Frequency Range (tuned): 2.5 MHz to 1.3 GHz Range: 0 dBm to -127 dBm Relative Power Accuracy: ± 0.5 dB AM Rates: 20 Hz to 100 kHz Depth: to 99% Accuracy: ± 1% of reading ± 1 count	HP 8902A ³	P15 AP1 AA1
Phase Noise Measurement System	Frequency Range (carrier): 0.01 to 18 GHz Sensitivity: < -70 dBc @ 100 Hz offset < -78 dBc @ 1 kHz offset < -86 dBc @ 10 kHz offset < -107 dBc @ 100 kHz offset Offset Frequency Range: 100 Hz to 2 MHz Amplitude Accuracy: ± 2 dB to 1 MHz offset	HP 3048A	P11

1. A slash "/" separating the models indicates either model may be used for the tests and adjustments listed in the "Use" column. If the models are listed without slashes then each of the models listed is recommended for use in those tests and adjustments listed directly across from the model.
 2. P - Manual performance test (by test number)
 A - Manual adjustment (by adjustment number)
 AP - Automated performance test (by test number)
 AA - Automated adjustment (by adjustment number)

3. Recommended model is part of the microwave test station.

Table 1-1. Required Test Equipment (3 of 4)

Instrument	Critical Specifications	Recommended Model ¹	Use ²
Preamplifier/ Power Amplifier	Frequency Range: 100 kHz to 1.3 GHz Preamplifier Gain: 25 dB Power Amplifier Gain: 22 dB ≥ 1 meter	HP 8447F	P13,14
Delay Line Discriminator	Frequency Range: 1 GHz to 20 GHz	HP P/N 08505-20038	P17
Mixer	Frequency Range: 10 MHz to 20 GHz	HP P/N 0955-0307	P13,15,19
Power Splitter	Frequency Range: dc to 20 GHz	HP 11667B	P19
Crystal Detector	Maximum Input: 200 mW Polarity: Negative	HP 33330D	P16
Directional Coupler	Frequency Range: 2 to 20 GHz Coupling: 16 dB Maximum Input Power: 100 mW	HP P/N 0955-0148	A10
3.7 GHz Low Pass Filter		HP P/N 9135-0191	P14
130 MHz Bessel Low Pass Filter		K & L Microwave 5LL30-130/BT2400/BP	P14
Attenuator	Frequency Range: 10 MHz to 20 GHz Maximum Input Power: Attenuation: 6 dB 10 dB	HP 8493C Opt 006 HP 8493C Opt 010	
Tool Kit	No Substitute	HP P/N 08360-60060 California Instruments 501TC	P10
Invertron		HP 11356A	P10
Ground Isolator			

1. A slash "/" separating the models indicates either model may be used for the tests and adjustments listed in the "Use" column. If the models are listed without slashes, then each of the models listed is recommended for use in those tests and adjustments listed directly across from the model.
 2. P - Manual performance test (by test number)
 A - Manual adjustment (by adjustment number)
 AP - Automated performance test (by test number)
 AA - Automated adjustment (by adjustment number)
 3. Recommended model is part of the microwave test station.

Table I-1. Required Test Equipment (4 of 4)

Instrument	Critical Specifications	Recommended Model ¹	Use ²
Capacitor Modular Spectrum Analyzer	1000 pf (Required for automated tests and may be substituted in manual tests)	HP P/N 0160-4574	P7
Mainframe		HP 70001	AP1 AA1
Display		HP 70206A	AP1 AA1
Local Oscillator		HP 70900A	AP1 AA1
RF Section	Frequency Range: 100 Hz to 2.9 GHz	HP 70904A	
RF Section	Frequency Range: 50 kHz to 26.5 GHz	HP 70906A	
RF Section	Frequency Range: 50 kHz to 22 GHz (Required for automated Step Attenuator Flatness test and adjustment only)	HP 70908A	AP1 AA1
IF Section	Resolution Bandwidth: 10 Hz to 300 kHz	HP 70902A	AP1 AA1
IF Section	Resolution Bandwidth: 100 kHz to 3 MHz	HP 70903A	
Frequency Reference	External reference input	HP 70310A	AP1 AA1
Tracking Generator		HP 70300A	
Preselector		HP 70600A	

1. A slash "/" separating the models indicates either model may be used for the tests and adjustments listed in the "Use" column. If the models are listed without slashes, then each of the models listed is recommended for use in those tests and adjustments listed directly across from the model.

2. P - Manual performance test (by test number)
 A - Manual adjustment (by adjustment number)
 AP - Automated performance test (by test number)
 AA - Automated adjustment (by adjustment number)

3. Recommended model is part of the microwave test station.

2 PERFORMANCE TESTS

2. HP 8360 Series Performance Tests

HOW TO USE THIS CHAPTER

Use the procedures in this chapter to test the electrical performance of the synthesizer. These tests (listed in table 2-1) do not require access to the interior of the instrument.

Note



The synthesizer must warm up for at least *one hour* before the electrical specifications are valid.

Note



In all cases where you are instructed to preset the synthesizer, use the factory preset mode only.

Menus

If you are not familiar with the menus in this instrument, go to the "MENU" chapter and fold out the menu maps (see the following figure).

Some menus have more than one page of softkeys. Select the **[more]** softkey to view the next page of softkeys. **[more]** is *not* included in the keystrokes given in these procedures.

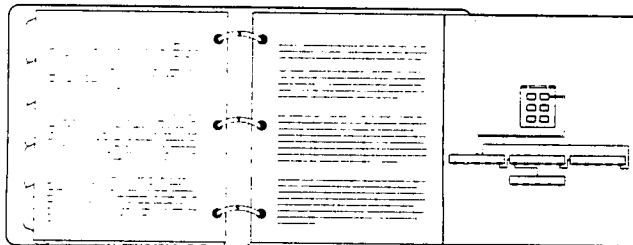

OPERATOR'S CHECK

For assurance that most of the internal functions of the instrument work (without testing for specifications), see "Operator's Check," in the *User's Handbook*.

OPERATION VERIFICATION

To meet the needs of most incoming inspections (80% verification), and provide a reasonable assurance that the instrument works, see the "Operation Verification" section of this chapter.

AUTOMATED PERFORMANCE TESTS

The automated performance tests available at time-of-shipment are included in the "AUTOMATED TESTS" chapter of this manual.

EQUIPMENT REQUIRED

The equipment required to perform the tests in this chapter is listed in the "EQUIPMENT REQUIRED" chapter of this manual. You may use any equipment that meets the critical specifications given.

TEST RECORD

Test records are supplied at the end of this chapter. Use a test record when you perform a full calibration of your synthesizer. This form provides a tabulated index of the performance tests, their acceptable limits, and a column to record actual measurements.

Note



There may be more than one test record. Be sure you use the one designated (at the top) for your synthesizer.

TEST SEQUENCE

Perform the tests in the order that they appear.

CALIBRATION CYCLE

Perform the tests in this chapter at least once every 24 months.

Table 2-1. Performance Tests

Test	Page
1. Internal Timebase: Aging Rate	2-5
2. Swept Frequency Accuracy	2-9
3. Frequency Switching Time	2-13
4. Power Accuracy	2-19
5. Power Flatness	2-21
6. Maximum Leveled Power	2-23
7. External Leveling	2-27
8. Spurious Signals (Harmonics & Subharmonics)	2-29
9. Spurious Signals (Non-Harmonics)	2-33
10. Spurious Signals (Line Related)	2-37
11. Single Sideband Phase Noise	2-41
12. Pulse Modulation On/Off Ratio	2-47
13. Pulse Performance	2-51
14. Pulse Modulation Video Feedthrough	2-57
15. AM Accuracy	2-63
16. AM Bandwidth	2-65
17. AM Dynamic Range	2-69
18. FM Accuracy	2-73
19. FM Bandwidth	2-77
20. Maximum FM Deviation	2-83
Step Attenuator Flatness (see "Automated Tests").	

1. INTERNAL TIMEBASE: AGING RATE

Description and Procedure

This procedure checks the accuracy of the internal time base. The time required for a specific phase change is measured both before and after a specified waiting period. The aging rate is inversely proportional to the absolute value of the difference in the measured times.

The overall accuracy of the internal time base is a function of:

$$TBC \pm AR \pm TE \pm LE$$

TBC = time base calibration

TE = temperature effects

AR = aging rate

LE = line effects

After the time base is adjusted, the timebase frequency should stay within the aging rate if the following things happen:

- The timebase oven does not cool down.
- The instrument keeps the same orientation with respect to the earth's magnetic field.
- The instrument stays at the same altitude.
- The instrument does not receive any mechanical shock.

If the time base oven cools (the instrument is disconnected from ac power), you may have to readjust the time base frequency after a new warmup cycle. Typically, however, the time base frequency returns to within ± 1 Hz of the original frequency.

Note



The internal timebase can be tested after reconnecting ac power for 10 minutes, but for best accuracy, test again after the instrument has been on or in standby condition for 24 hours.

Frequency changes due either to a change in orientation with respect to the earth's magnetic field, or to a change in altitude, usually go away when the instrument is returned to its original position. A frequency change due to mechanical shock usually appears as a fixed frequency error.

1. Connect the equipment as shown in figure 2-1. Preset all instruments and let them warm up for at least one hour.

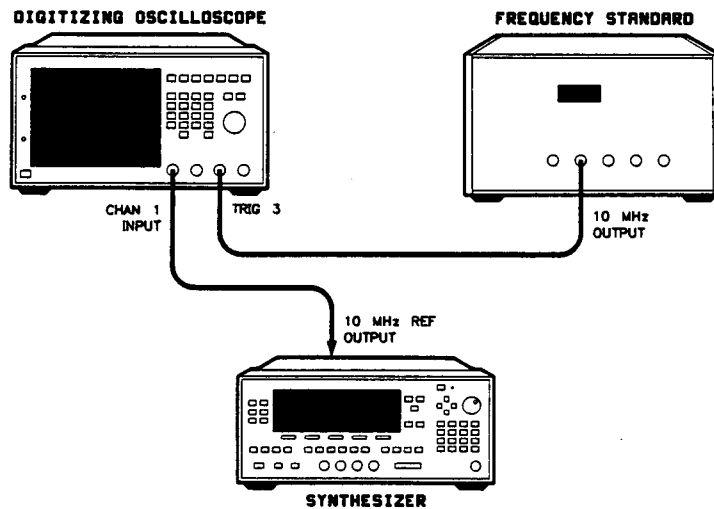

Note



If the oscilloscope does not have a 50 Ω input impedance, connect channel 1 through a 50 Ω feedthrough.

Figure 2-1. Internal Timebase: Aging Rate Test Setup

2. On the oscilloscope, adjust the external triggering for a display of the 10 MHz REF OUTPUT signal from the synthesizer:

Channel 1:

Display	On
Volts/Division	120 mV
Offset	0V
Input Coupling	dc
Input Impedance	50 Ω

Channel 2:

Display	Off
---------	-----

Timebase:
 Time/Division 5 ns
 Delay 0s
 Delay Reference At center
 Sweep Auto

Trigger:
 Trigger Mode Edge
 Trigger Source Trig 3
 Input 50Ω

Display:
 Display Mode Real time

3. Monitor the time and the display. Note the time required for a 360° phase change:
T1 = _____ (s)
4. Wait 3 to 24 hours. Note how long you waited:
T2 = _____ (h)
5. Repeat step 3. Record the phase change time:
T3 = _____ (s)

6. Calculate the aging rate as follows:
 Aging Rate = (1 cycle/10 MHz) (1/T1 – 1/T3) (24 hours/T2)

Example: T1 = 351 seconds
 T2 = 3 hours
 T3 = 349 seconds
 = (1 cycle/10 MHz) (1/351s – 1/349s) (24h/3h)
 = 1.306x10⁻¹¹ per day

7. Enter the aging rate on the test record.

Note



If the absolute frequency of the standard and of the time base oscillator are extremely close, you can reduce the measurement time (T1 and T3) by measuring the time required for a phase change of less than 360°. In step 6, change 1 cycle to 0.5 cycle for 180°, or 0.25 cycle for 90°.

Related Adjustments

10 MHz Standard

In Case of Difficulty

1. Ensure that the instruments have warmed up long enough and that environmental conditions have not changed throughout the test.
2. If the frequency standard and the internal standard are very different in frequency, the time required for a 360° phase shift is too short for an accurate measurement. If the 360° phase shift takes less than two minutes, perform the "10 MHz Standard" adjustment.
3. See "TROUBLESHOOTING" in the *Assembly-Level Repair* manual.

2. SWEPT FREQUENCY ACCURACY

Description and Procedure

With the synthesizer in swept mode, the spectrum analyzer is set to zero span at the measurement frequency. As the synthesizer sweeps through the spectrum analyzer frequency setting, a signal is generated on the spectrum analyzer's video output that is input to the oscilloscope.

The synthesizer's TRIGGER OUTPUT used to trigger the oscilloscope, is a series of 1601 pulses, evenly spaced during the sweep. The oscilloscope is triggered on the pulse that represents the desired measurement frequency, and the spectrum analyzer is tuned to display the video output on the oscilloscope.

1. Connect the equipment as shown in figure 2-2. Preset all instruments and let them warm up for at least one hour.

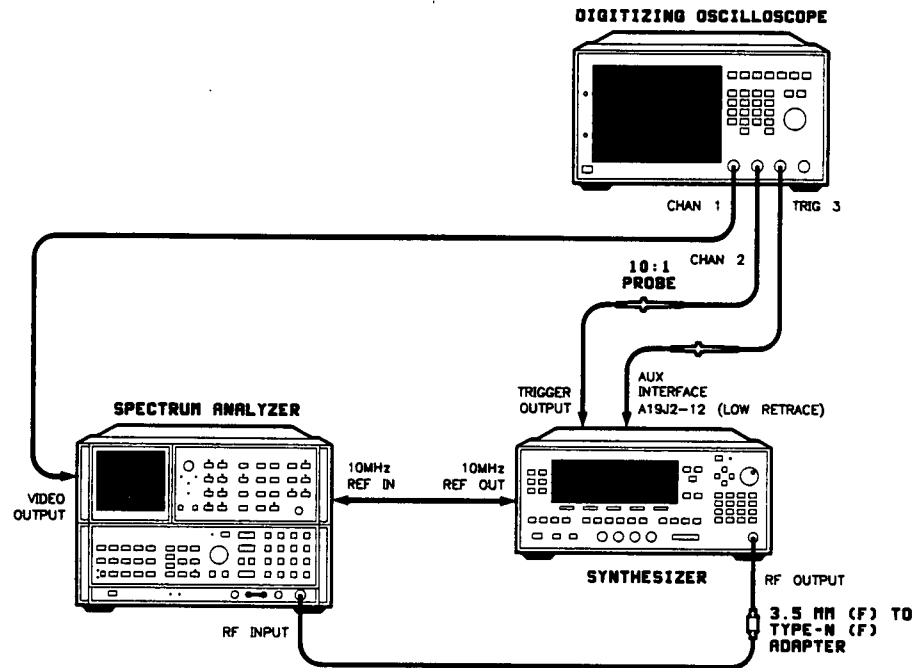

Figure 2-2. Swept Frequency Accuracy Test Setup

2. On the spectrum analyzer, set:

Frequency:	First center frequency in table 2-2
Span:	0 Hz
Reference Level:	0 dBm
Scale Log:	10 dB/div
Resolution Bandwidth:	100 kHz

3. Set the oscilloscope as follows:

Note



Trigger 3 is a trigger enable that ensures that channel 2 (the true trigger) triggers only on a forward sweep after the specified number of events.

Channel 1:

Display	On
Volts/Division	300 mV
Input Coupling	dc
Input Impedance	1 M Ω

Channel 2:

Display	On
Volts/Division	1V
Offset	2V
Input Coupling	dc
Input Impedance	1 M Ω

Timebase:

Time/Division	50 μ s
Delay	5.5 μ s
Delay Reference	At center
Sweep	Triggered

Trigger:

Trigger Mode	Edge
Trigger Source	Chan 2
Trigger Level	1.6V
Trigger Source	Trig 3
Trigger Level	1.6V
Trigger Mode	Events
Trigger	After Positive edge
Trigger	On Trig 3
Trigger	First trigger events in table 2-2
Trigger	Of positive edge
Trigger	On channel 2

Display:

Display mode	Real time
--------------	-----------

4. On the synthesizer, set:

USER CAL [*Freq Cal Menu*] [*Swp Span Cal Always*] (asterisk on)

START First start frequency in table 2-2

STOP First stop frequency in table 2-2

Note



Set the frequency range first, or you cannot set the sweep time properly.

CONT **SWEEP TIME** 100 ms

POWER LEVEL 0 dBm

Table 2-2. Swept Frequency Accuracy Instrument Settings

Synthesizer Frequency (GHz)		Spectrum Analyzer Center Frequency (GHz)	Oscilloscope Trigger Events	Frequency Error	Percent
Start	Stop				
2.3	7	2.399875	34	_____	_____
2.3	7	6.8971875	1565	_____	_____
7	12.5	7.199375	58	_____	_____
7	12.5	12.2971875	1541	_____	_____
15	20	15.2	64	_____	_____
15	20	19.696875	1503	_____	_____
2.3	12.5	2.395625	15	_____	_____
2.3	12.5	6.896375	721	_____	_____
2.3	12.5	7.196	768	_____	_____
2.3	12.5	12.296	1568	_____	_____
7	20	7.195	24	_____	_____
7	20	12.2975	652	_____	_____
7	20	12.695625	701	_____	_____
7	20	19.796875	1575	_____	_____
2.3	20	2.3995625	9	_____	_____
2.3	20	6.8909375	415	_____	_____
2.3	20	7.189625	442	_____	_____
2.3	20	12.2894375	903	_____	_____
2.3	20	12.69875	940	_____	_____
2.3	20	19.7898125	1581	_____	_____

5. Tune the spectrum analyzer center frequency to find and center the video signal on the oscilloscope (see figure 2-3). Align the video input with the trigger output at center screen.

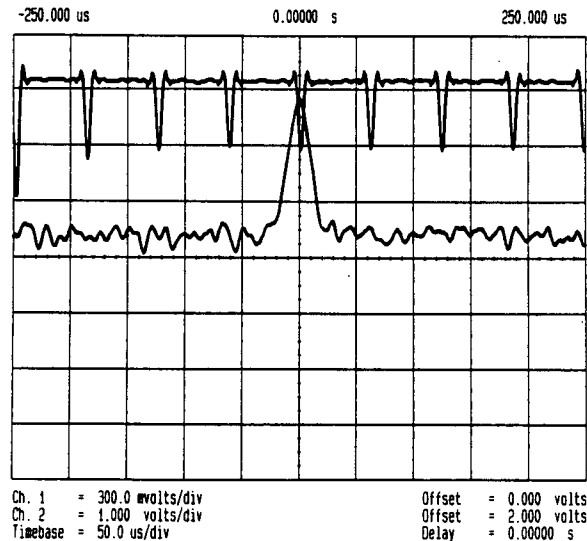

Figure 2-3. Video Signal on the Oscilloscope

6. Note the final center frequency setting required to center the video signal.
7. Record the difference between the initial center frequency setting and the value noted in step 6 in table 2-2 as frequency error.
8. Repeat steps 5 through 7 for the remaining instrument settings in table 2-2.
9. Calculate the frequency error as a percent of the sweep width as follows for each of the results in table 2-2:

$$\frac{\text{frequency error}}{\text{stop frequency} - \text{start frequency}} = \text{percent}$$

10. Record the worst case value on the test record.

Related Adjustments

YO Driver +10V Reference
 YO Gain and Linearity
 YO Delay Compensation
 Sweep Ramp Calibration

In Case of Difficulty

1. Verify that the spectrum analyzer frequency is accurate. If necessary, calibrate the frequency with the synthesizer's 10 MHz reference connected to the spectrum analyzer's external reference.
2. See "TROUBLESHOOTING" in the *Assembly-Level Repair* manual.

3. FREQUENCY SWITCHING TIME

Description and Procedure

The synthesizer's Z-AXIS BLANK/MARKER output goes active high when a change in frequency is initiated, and returns low when the synthesizer settles at the new frequency. Using an oscilloscope to monitor this output, you measure frequency switching time in CW, step sweep, and frequency list modes.

1. Connect the equipment as shown in figure 2-4. Preset both instruments and let them warm up for at least one hour.

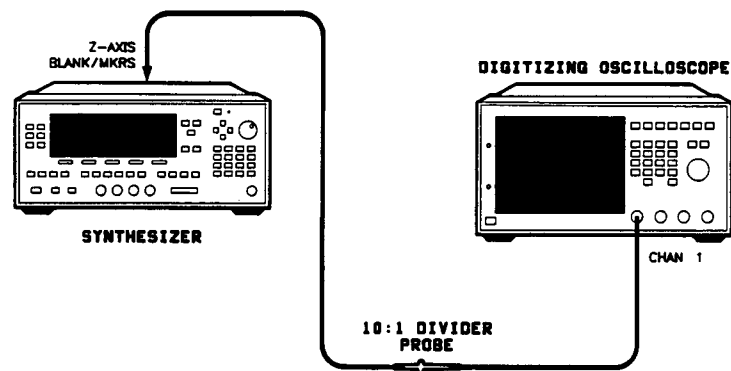

Figure 2-4. Frequency Switching Time Test Setup

CW Frequency Switching Time

2. On the oscilloscope, set:

Channel 1:

Display On
 Preset TTL
 Input Coupling dc

Channel 2:

Display Off

Timebase:

Time/Division 10 ms
 Delay Reference At left
 Delay -10 ms
 Sweep Triggered

Trigger:

Trigger Mode Edge
 Trigger Source Channel 1
 Trigger Level 1.6V
 Trigger Slope Positive

Display:

Display Mode Repetitive

3. On the synthesizer, set the first *Initial CW Frequency* in table 2-3.

4. On the oscilloscope, clear the display.

The oscilloscope should display *Awaiting Trigger*.

5. On the synthesizer, set the first *Second CW Frequency* in table 2-3.

Table 2-3. CW Frequency Switching Time Settings

Initial CW Frequency (GHz)	Second CW Frequency (GHz)	Pulse Width
0.01*	20	_____
12.5	20	_____

* Set to 2 GHz (lowest start frequency) for synthesizers not capable of 0.01 GHz.

6. On the oscilloscope, note the pulse width of the Z-axis blank/markers signal. Record this value as pulse width in table 2-3.

7. Clear the oscilloscope display and repeat steps 3 through 6 for the remaining frequencies in table 2-3.

8. On the test record, record the maximum pulse width from table 2-3.

Stepped Sweep Frequency Switching Time

9. On the synthesizer, set:

FREQUENCY [*Step Swp Menu*] [*Step Size*]

[*Step Dwell*]

SWEEP [*Sweep Mode Step*]

10. On the oscilloscope, set:

Channel 1:

Display	On
Preset	TTL
Input Coupling	dc

Timebase:

Time/Division	2 ms
Delay	-2 ms
Delay Reference	At left
Sweep	Triggered

Trigger:

Trigger mode	Events
Trigger	After negative edge
Trigger Source	Channel 1
Trigger	On 1 events
Trigger	Of positive edge
Trigger	On channel 1

Display:

Display Mode	Repetitive
--------------	------------

11. Set the oscilloscope for a single sweep at the next trigger. Press:

The oscilloscope displays **Awaiting Trigger**

12. On the synthesizer, initiate a stepped sweep. Press:

13. On the oscilloscope:

Measure the positive pulse width and note the value _____.

14. Increment the trigger to 20 events and repeat steps 11 through 13.
Pulse width value _____.
15. Increment the trigger to 45 events and repeat steps 11 through 13.
Pulse width value _____.
16. Record the worst case value from steps 13 through 15 on the test record.

Frequency List Frequency Switching Time

17. On the synthesizer, delete any entries in the frequency list menu:

FREQUENCY **(MENU)** [*List Menu*] [*Delete Menu*] [*All*]

18. On the synthesizer, press [*Enter List Freq*] and enter the following frequencies in the frequency list menu:

Frequency (GHz)
2.2
2.4
6.9

19. On the oscilloscope, set:

Channel 1:

Display	On
Preset	TTL
Input Coupling	dc

Channel 2:

Display	Off
---------	-----

Timebase:

Time/Division	5 ms
Delay	-2 ms
Delay Reference	At left
Sweep	Triggered

Trigger:

Trigger Mode	Events
Trigger	After negative edge
Trigger Source	Channel 1
Trigger	On 1 events
Trigger	Of positive edge
Trigger	On channel 1

Display:

Display Mode	Repetitive
--------------	------------

20. On the synthesizer, set:

SINGLE

SWEEP **MENU** [*Sweep Mode List*]

SINGLE

21. On the oscilloscope, set a single sweep at the next trigger. Press:

Stop/Single

The oscilloscope displays **Awaiting Trigger**

22. On the synthesizer, initiate a frequency list sweep. Press:

SINGLE

23. On the oscilloscope:

Measure the positive pulse width, and note the value:

Pulse Width Value

1 event _____

2 events _____

3 events _____

4 events _____

5 events _____

6 events _____

7 events _____

8 events _____

9 events _____

24. Increment the trigger on events and repeat steps 20 through 24 for a trigger on events up to and including 9.

25. Record the worst case value from step 23 on the test record.

Related Adjustments

Fractional-N VCO
Sampler Assembly
YO Loop Gain

In Case of Difficulty

1. Verify that the oscilloscope triggers when stepping between two frequencies. If necessary, adjust the trigger level on the oscilloscope.
2. See "TROUBLESHOOTING" in the *Assembly-Level Repair* manual.

4. POWER ACCURACY

Description and Procedure

Using a power meter, check the power accuracy of the synthesizer at several CW frequencies. At each frequency, verify that the actual output power is within specification over the full dynamic range of the ALC loop.

1. Turn on the equipment shown in figure 2-5 and let them warm up for at least one hour.
2. On the power meter:
Zero and calibrate the power meter/sensor.
Set to dBm mode.
3. Connect the equipment as shown in figure 2-5 and press **PRESET**.
4. To achieve peak power, turn on RF peaking. Press:
USER CAL **[Tracking Menu]** **[Peak RF Always]** (asterisk on)

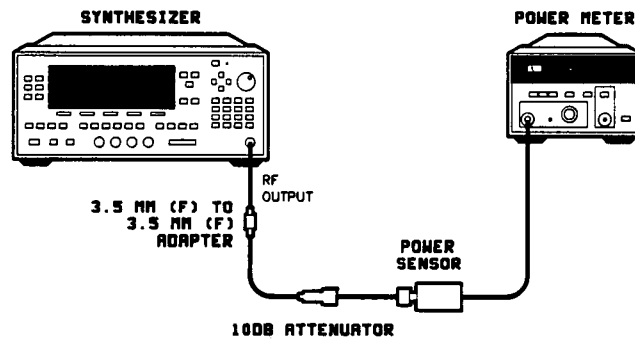

Figure 2-5. Power Accuracy Test Setup

5. On the synthesizer, set:
CW The first CW value in table 2-4
POWER **MENU** **[Up/Dn Power]** **1** **dB**
[Uncoupl Atten] (option 001 only)
POWER LEVEL **-10** **dBm**
RF ON/OFF Off (amber light off)

6. Zero the power meter.
7. On the synthesizer, turn the RF on (amber light on).

Table 2-4. Power Accuracy Frequencies

Frequency (GHz)	Measured Difference
0.1*	_____
1.0*	_____
6.0	_____
10.0	_____
18.0	_____
* Not applicable for all models	

8. On the power meter, set the power sensor calibration factor for the frequency to be measured.
9. Note the difference between the power meter reading and the power value set on the synthesizer.

Note



For power levels of 0 dBm and above, measure the power at 0 dBm, then set the attenuator to the 10 dB position (use a 10 dB attenuator for synthesizers without a step attenuator.) Record the difference between the measurements: _____ (approximately 10 dB). Then, with the attenuator still set to 10 dB, complete the remaining measurements. Each of these measurements should be offset by the difference in dB that you measured.

10. On the synthesizer, use the up (↑) key to increment the power level 1 dB.
11. Repeat steps 8 through 10, to the maximum specified power level. Record the worst case measured difference for this frequency in table 2-4.
12. On the synthesizer, set the power level to -10 dBm.
13. Repeat steps 7 through 11 for the remaining frequencies in table 2-4.
14. Record the worst case measured values below 2.3 GHz and above 2.3 GHz on the test record.

Related Adjustments

Modulator Offset and Gain
Power Meter Leveling Accuracy

In Case of Difficulty

See "TROUBLESHOOTING" in the *Assembly-Level Repair* manual.

5. POWER FLATNESS

Description and Procedure

This procedure uses the user flatness correction array to automatically measure power flatness. The power meter is connected directly to the synthesizer's RF output. The synthesizer controls the power meter via HP-IB while the power meter measures the RF output. (There cannot be another controller on the HP-IB during this test.) If the synthesizer has a step attenuator, it is set to 0 dB so that any input into the flatness array indicates the RF output power flatness.

Note



This performance test requires an HP 437B power meter. The correct power sensor calibration factors must be loaded and selected.

Caution



This procedure deletes any existing user flatness correction array.

1. Turn on the equipment shown in figure 2-6. Connect the power sensor for the frequency range being calibrated. Do not connect the power sensor to the synthesizer yet. Preset all instruments and let them warm up for at least one hour.

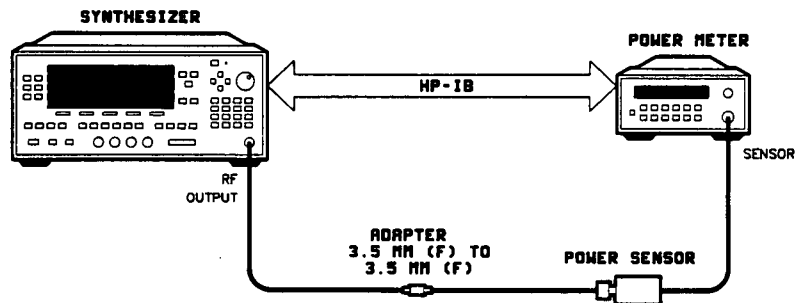

Figure 2-6. Power Flatness Test Setup

Low Band Power Flatness (not applicable for all models)

2. In the synthesizer's flatness menu:
 - a. Delete all entries in the user flatness correction array:
POWER **[MENU]** **[Fitness Menu]** **[Delete Menu]** **[Delete All]**
 - b. Set the auto fill start frequency to 15 MHz:
[Auto Fill Start] **[15]** **[MHZ]**

- c. Set the auto fill stop frequency to 2.3 GHz:

[Auto Fill Stop] (2.3) (GHz)

- d. Set the auto fill increment to 10 MHz:

[Auto Fill Incr] (10) (MHz)

3. On the power meter, load the calibration factors for the power sensor.

Zero and calibrate the power meter/sensor.

Connect the power sensor to the synthesizer's RF OUTPUT as shown in figure 2-6.

4. Set the synthesizer to measure the power correction values and generate a new user flatness array for the frequency range entered. Select:

[Mtr Meas Menu] **[Meas Corr All]**

When the flatness correction array is completed, the following message is displayed on the synthesizer: Cal Completed

5. Scroll through the user flatness correction values using the up/down arrow keys. Note the maximum and minimum correction values. The difference between them is the power flatness measurement. Record the value on the test record and compare the value to the specification.

High Band Power Flatness

6. With the appropriate power sensor for this frequency range, repeat steps 2 through 5 for:

- A 2.35 GHz start frequency.
- A 20 GHz stop frequency.
- A 100 MHz increment.

Related Adjustments

Power Flatness

In Case of Difficulty

1. The power meter must be an HP 437B.
2. The correct calibration factors for the power sensor must be loaded.
3. See "TROUBLESHOOTING" in the *Assembly-Level Repair* manual.

6. MAXIMUM LEVELED POWER

Note



This performance test is not valid unless the synthesizer meets both its power accuracy and power flatness specifications. Perform those tests first.

Description and Procedure

The unlevelled status indicator is displayed when the instrument is unlevelled as the synthesizer sweeps over specific frequency ranges in fast continuous sweep, and fast and slow single sweep operation. Because of the synthesizer's power accuracy and flatness performance, a power meter is not required for this measurement. The following procedure tests the most likely worst case situations for maximum leveled power.

1. Turn on the equipment shown in figure 2-7. Preset the synthesizer and let it warm up for at least one hour.

Note



The 20 dB attenuator provides a good match on the RF output. If the synthesizer has a step attenuator, you can simulate a good match by decoupling the step attenuator from the ALC and setting the attenuator to 20 dB.

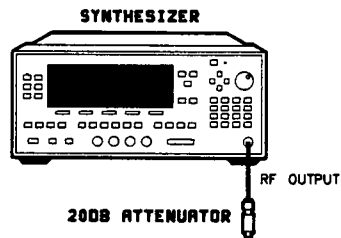

Figure 2-7. Maximum Leveled Power Test Setup

- To achieve peak power, initiate auto tracking on the synthesizer as follows. Terminate the RF OUTPUT with a good 50 ohm impedance match such as a 10 dB attenuator or a power sensor (not necessary for synthesizers with a step attenuator.) Press:

POWER **(MENU)** **[Tracking Menu]** **[Auto Track]**

Wait for the synthesizer to complete auto tracking before continuing to the next step.

- Connect the equipment as shown in figure 2-7.

- On the synthesizer, set:

(POWER LEVEL) Set the power to 1 dB below the specified maximum leveled power.

(RF ON/OFF) (amber light is on)

(CONT) **(SWEEP TIME)** **(0)** **(ms)** (minimum)

(START) First start frequency in table 2-5

(STOP) First stop frequency in table 2-5

Table 2-5. Maximum Leveled Power Test Frequencies

Frequency (GHz)		Power Level
Start	Stop	
Low end of frequency range	High end of frequency range	_____
2.2	"	_____
6.8	"	_____
12.2	"	_____
Low end of frequency range	7.2	_____

- Increase the power level until the unleveled status indicator comes on, then reduce the power level until the indicator just goes off. (Power is leveled).
- Set the sweep to **(SINGLE)** and initiate several sweeps. If necessary, reduce the power level until the unleveled status indicator does not turn on while sweeping.
- On the synthesizer, set:

(SWEEP TIME) **(0.5)** **(sec)**

Initiate several sweeps. If necessary, reduce the power level until the unleveled status indicator does not turn on while sweeping.

Note the power level in table 2-5.

8. On the synthesizer, press:

CONT **SWEEP TIME** **0** **msec** (minimum)

9. Repeat steps 5 through 7 for the remaining frequency ranges in table 2-5.

10. Record the worst case value from table 2-5 on the test record.

Related Adjustments

SYTM Adjustments
Modulator Offset and Gain

In Case of Difficulty

See "TROUBLESHOOTING" in the *Assembly-Level Repair* manual.

7. EXTERNAL LEVELING

Description and Procedure

The synthesizer is set up to externally level using a negative crystal detector. A DVM measures the crystal detector dc output. A 1000 pf capacitor across the DVM input limits the effect of any small signals generated by the DVM. The synthesizer power level is set to the minimum allowable limit and then is increased until the power output is leveled. The external leveling voltage is then measured and compared to the minimum specification. Next, the output power is increased until the maximum leveled power is reached. The leveling voltage is measured and compared to the specification.

Note



The synthesizer must meet the power flatness specification before proceeding with this test.

1. Preset all instruments shown in figure 2-8 and let them warm up for at least one hour.

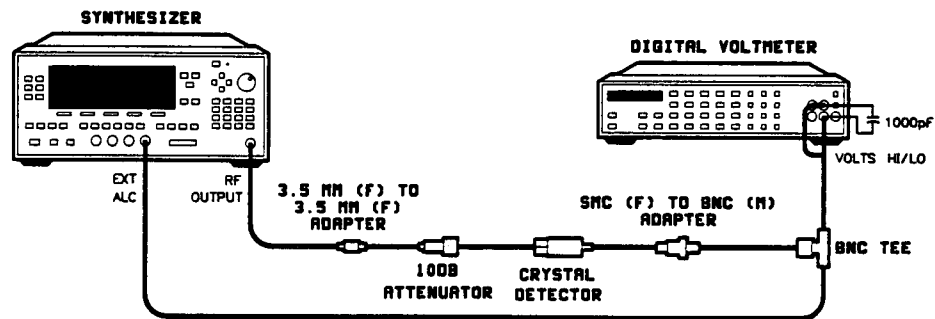

Figure 2-8. External Leveling Test Setup

2. To achieve peak power, initiate auto tracking on the synthesizer as follows. Terminate the RF OUTPUT with a good 50Ω impedance match such as a 10 dB attenuator or a power sensor (not necessary for synthesizers with a step attenuator). Press:

USER CAL **[Tracking Menu]** **[Auto Track]** (asterisk on)

Wait for the synthesizer to complete auto tracking before continuing to the next step.

3. Connect the equipment as shown in figure 2-8.

4. On the synthesizer, set:

ALC **[Leveling Point ExtDet]** **[Coupling Factor]** **-** **10** **dB**

POWER LEVEL **-** **26** **dBm**

5. Set the DVM to measure dc volts.

6. Increase the synthesizer power level until the LOW UNLVLED message turns off. (If it is already out, leave the power level at -36 dBm.)
7. On the synthesizer, set:
CW **10** **GHz**
Record the DVM reading on the test record and compare the reading to the specification.
8. On the synthesizer, set:
START (to initiate a full sweep)
POWER LEVEL Increase the synthesizer power level until the UNLVLED message turns on. Decrease power just until the message goes out.
9. On the synthesizer, set:
CW **10** **GHz**
Record the DVM reading on the test record and compare the reading to the specification.

Related Adjustments

SYTM Adjustments
Power Flatness

In Case of Difficulty

1. Be sure you are externally leveling with a negative crystal detector.
2. If the DVM readings are not within the specifications, perform an external detector calibration (under the **USER CAL** key.)
3. See "TROUBLESHOOTING" in the *Assembly-Level Repair* manual.

8. SPURIOUS SIGNALS (HARMONIC)

Description and Procedure

Use this procedure to measure the synthesizer's harmonics and subharmonics over its entire frequency range. Harmonics are integer multiples of the synthesizer RF output frequency and subharmonics are fractional multiples of the YO frequency. Subharmonics do not exist at all frequencies. In low band, mixer spurs and fundamental feedthrough are the most significant harmonically-related signals. The mixer spur/YO frequency relationship is as follows:

$X (5.4 \text{ GHz fixed oscillator}) - Y (\text{YO frequency}) = \text{Mixer Spur Frequency}$
where X and Y are integers.

Other harmonics are typically direct multiples of the YO frequency.

In this procedure, the synthesizer is manually swept over its frequency range while the spectrum analyzer measures the harmonics and subharmonics in each frequency band. Any harmonics or subharmonics that are within 5 dB of the specification are subsequently verified with a more accurate procedure.

1. Preset the instruments shown in figure 2-9 and let them warm up for at least one hour.

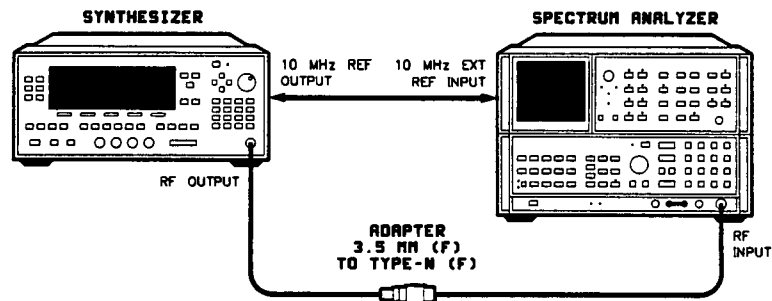

Figure 2-9. Spurious Signals (Harmonic) Test Setup

2. To achieve peak power, turn on RF peaking. Set:
USER CAL [*Tracking Menu*] [*Peak RF Always*] (asterisk on).
3. Connect the equipment as shown in figure 2-9.

4. On the synthesizer, set:

POWER LEVEL Set the maximum specified leveled power.

SWEEP MENU [*Manual Sweep*]

5. On the spectrum analyzer, set:

Frequency: First set of start and stop frequencies from table 2-6 or table 2-7.

Reference Level: 0 dBm

Scale Log: 5 dB/Division

Bandwidth Resolution: 3 MHz

Video Bandwidth 3 MHz

Table 2-6. 10 MHz to 20 GHz Synthesizers: Spectrum Analyzer Start and Stop Frequencies

Start Frequency (GHz)	Stop Frequency (GHz)
0.01	2.4
2.4	7.0
7.0	12.5
12.5	20.0

Table 2-7. 2 GHz to 20 GHz Synthesizers: Spectrum Analyzer Start and Stop Frequencies

Start Frequency (GHz)	Stop Frequency (GHz)
2.0	7.0
7.0	12.5
12.5	20.0

6. Manually sweep the synthesizer across its entire frequency range while checking the spectrum analyzer display for harmonics and subharmonics.

See table 2-8 or 2-9 for the YO frequency ranges that correspond to the RF output frequencies.

**Table 2-8. 10 MHz to 20 GHz Synthesizers:
Corresponding YO Frequency Ranges and RF Output Frequencies**

YO Frequencies (GHz)	Harmonic	RF Output Frequencies (GHz)
5.41 to 7.7	N/A	0.01 to 2.3
2.3 to 7.0	1	2.3 to 7.0
3.5 to 6.25	2	7.0 to 12.5
4.167 to 6.67	3	12.5 to 20.0

**Table 2-9. 2 GHz to 20 GHz Synthesizers:
Corresponding YO Frequency Ranges and RF Output Frequencies**

YO Frequencies (GHz)	Harmonic	RF Output Frequencies (GHz)
2.0 to 7.0	1	2.0 to 7.0
3.5 to 6.25	2	7.0 to 12.5
4.167 to 6.67	3	12.5 to 20.0

7. Compare the amplitude of the harmonics/subharmonics to the specifications listed in the test record. Record the value of the worst harmonic/subharmonic for each of the frequency ranges listed on the test record. However, if any harmonic/subharmonic is within 5 dB of specification, make a more accurate measurement using the "Harmonic/Subharmonic Verification Procedure" that follows.
8. Repeat steps 5 through 7 for each set of start and stop frequencies in table 2-6 or table 2-7.

Harmonic/Subharmonic Verification Procedure

1. Set the synthesizer to the RF output frequency that corresponds to the harmonic or subharmonic to be measured.
2. On the spectrum analyzer, set:

Frequency:	Same frequency as the synthesizer
Span:	1 MHz
Reference Level:	+20 dBm
Scale Log:	5 dB/Division
Bandwidth Resolution:	10 kHz
Video Bandwidth:	30 kHz

3. Measure the synthesizer RF output amplitude with the spectrum analyzer marker.
4. Set the spectrum analyzer to the harmonic or subharmonic frequency to be measured. Measure the signal level with the spectrum analyzer marker. Change the reference level as necessary.
5. Calculate the harmonic/subharmonic level, where the harmonic/subharmonic is less than the carrier, as follows:

$$\text{Harmonic/Subharmonic amplitude (dBc)} = -[\text{Synthesizer RF output amplitude (dBm)} - (\text{Harmonic/Subharmonic amplitude (dBm)})]$$

For example:

$$\begin{aligned} \text{RF Output} &= +10 \text{ dBm} \\ \text{Harmonic} &= -60 \text{ dBm} \\ \text{Harmonic (dBc)} &= [\text{RF Out} - (\text{Harmonic})] \\ &= -[10 - (-60 \text{ dBm})] \\ &= -[10 + 60 \text{ dBm}] \\ &= -70 \text{ dBc} \end{aligned}$$

Related Adjustments

None

In Case of Difficulty

See "TROUBLESHOOTING" in the *Assembly-Level Repair manual*.

9. SPURIOUS SIGNALS (NON-HARMONIC)

Description and Procedure

Use this procedure to measure known, fixed, offset spurs that are generated in the frequency synthesis section of the synthesizer. The synthesizer is set to various CW frequencies where these spurious signals will most likely occur. Then the spectrum analyzer is tuned to the spur frequencies to measure their levels.

1. Preset the instruments shown in figure 2-10 and let them warm up for at least one hour.

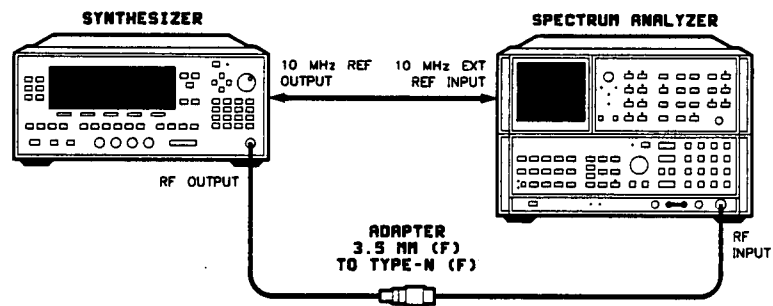

Figure 2-10. Spurious Signals (Non-Harmonic) Test Setup

2. To achieve peak power, turn on RF peaking. Set:
USER CAL **[Tracking Menu]** **[Peak RF Always]** (asterisk on)
3. Connect the equipment as shown in figure 2-10.

Fixed Spurious Signals

4. On the synthesizer, set:
CW **19.765** **GHz**
POWER LEVEL Set the maximum specified leveled power.

5. On the spectrum analyzer, set:

Center Frequency: 19.765 GHz
Frequency Span: 100 Hz
Reference Level: 20 dBm
Scale Log: 5 dB/Division
Resolution Bandwidth: 10 Hz
Sweep Time: Auto
Marker: Set to 19.765 GHz

6. On the spectrum analyzer, set the marker to the highest peak and note the frequency difference of the marker from the center frequency. Calibrate the spectrum analyzer frequency offset so that the signal peak is in the center of the display.
7. Note the signal amplitude on the spectrum analyzer. This is the carrier amplitude to which the spurs are referenced.

_____ dBm Carrier Amplitude

8. On the spectrum analyzer, set:

Center Frequency: Spectrum analyzer frequency for the first spur from table 2-10
Reference Level: -30 dBm
Video Averaging: On 100 samples
Marker: Same as spectrum analyzer frequency

9. Locate the spur corresponding to the spectrum analyzer frequency (see table 2-10) and use the marker to measure its amplitude. If the spur is in the noise level, use the noise level amplitude (this gives a worst case value).

_____ dBm Spur Absolute Amplitude

10. Calculate the spur level in dBc as follows:

Carrier Amplitude (dBm) - Spur Absolute Amplitude (dBm) = Spur Level (dBc)

Record the result on the test record. Compare the result to the specification.

11. Repeat steps 8 through 10 for each of the spurs and spectrum analyzer frequencies in table 2-10.

Table 2-10. Spectrum Analyzer Frequencies and Corresponding Spur Frequencies

Spur Frequency* (kHz)	Spectrum Analyzer Frequency (Hz)
20 + Calibration Constant #18	19,765,020,000
40 + 2(Calibration Constant #18)	19,765,040,000
60 + Calibration Constant #19	19,765,060,000
120 + 2(Calibration Constant #19)	19,765,120,000
125	19,765,125,000
500	19,765,500,000

* To determine the actual frequency of the spur, add the value of the calibration constant (or twice the value, where indicated) to the frequency. For example, set:

[SERVICE] [Adjust Menu] [Calib Menu] [Select Cal]

Use the RPG knob to select calibration constant #19. If the value for this calibration constant is -800 , the spur frequency calculation for the 60 kHz spur is:

$$60 \text{ kHz} + (-800) = 59.2 \text{ kHz.}$$

Low Band Spurious Signals

12. On the synthesizer, set:

[CW] [1] [GHz]

13. On the spectrum analyzer, set:

Center Frequency: 1 GHz
 Frequency Span: 500 Hz
 Reference Level: 20 dBm
 Resolution Bandwidth: Auto
 Video Bandwidth: Auto
 Marker: 1 GHz

14. Use the marker to measure the synthesizer's RF output amplitude at 1 GHz. This is the carrier amplitude to which the spurs are referenced.

_____ dBm RF output at 1 GHz

15. Set the spectrum analyzer center frequency to each of the frequencies in table 2-11. Use the marker to measure the spurs (change the reference level as necessary).

Calculate the spur level in dBc for each of the spurs as follows:

$$\text{Spur Level (dBc)} = -[\text{RF Output at 1 GHz (dBm)} - (\text{Spur Level})]$$

Record the spur level in dBc on the test record. Compare the spur level to the specification.

Table 2-11. Low Band Spurious Signals

Spectrum Analyzer Frequency	Spur
100 MHz 900 MHz 6.4 GHz	100 MHz Fixed Spur 100 MHz Offset Spur LO Feedthrough Spur

Related Adjustments

Fractional-N Reference and API Spurs

In Case of Difficulty

See "TROUBLESHOOTING" in the *Assembly-Level Repair* manual.

10. SPURIOUS SIGNALS (LINE-RELATED)

Description and Procedure

Use this procedure to measure line-related spurs. The synthesizer is placed at a CW frequency where the synthesizer is most sensitive to line-related spurs. The spectrum analyzer measures the RF output offset by the harmonics of the line power frequency (60 Hz or 50 Hz). To eliminate measuring the spectrum analyzer line related spurs, an Invertron is used to operate the spectrum analyzer at a different line frequency so that its own spurs will not affect the measurement.

Note



The spectrum analyzer must have a 10 Hz resolution bandwidth. A wider resolution bandwidth results in the synthesizer's phase noise masking the spur.

1. Set the invertron for a line frequency of 55 Hz and for normal operating voltage.
2. Connect the equipment as shown in figure 2-11. Preset the instruments and let them warm up for at least one hour.

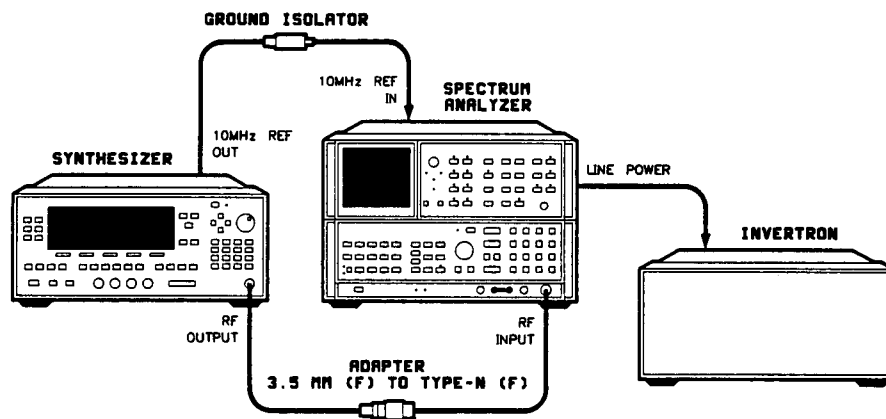

Figure 2-11. Spurious signals (Line-Related) Test Setup

3. To achieve peak power, turn on RF peaking. Set:
USER CAL [Tracking Menu] [Peak RF Always] (asterisk on)

4. On the synthesizer, set:

CW **6.99** **GHz**

POWER LEVEL **0** **dBm**

5. On the spectrum analyzer, set:

Center Frequency: 6.99 GHz
Frequency Span: 2 kHz
Reference Level: 10 dBm
Scale Log: 5 dB/Division
Resolution Bandwidth: 300 Hz
Sweep Time: Auto
Marker: Set to 6.99 GHz

6. On the spectrum analyzer, set the marker to the highest peak and note the frequency difference of the marker from the center frequency. Calibrate the spectrum analyzer frequency offset so that the signal peak is in the center of the display.
7. Note the signal amplitude on the spectrum analyzer. This is the carrier amplitude to which the spurs are referenced.

_____ dBm Carrier Amplitude

Note



This procedure is written for a line frequency of 60 Hz. For a 50 Hz line frequency, look for spurs at frequencies of 50 Hz times the harmonics in table 2-12, and set the spectrum analyzer frequencies accordingly.

8. On the spectrum analyzer, set:

Center Frequency: Spectrum analyzer frequency for the first spur from table 2-12
Reference Level: -50 dBm
Frequency Span: 100 Hz
Resolution Bandwidth: 10 Hz
Marker: Same as spectrum analyzer frequency
Video Averaging: On 100 samples

9. Locate the spur corresponding to the spectrum analyzer frequency (see table 2-12) and use the marker to measure its amplitude. If the spur is in the noise level, use the noise level amplitude (this gives a worst case value).

_____ dBm Spur Absolute Amplitude

10. Calculate the spur level in dBc as follows:

$$\text{Spur Level (dBc)} = -[\text{Carrier Amplitude (dBm)} - (\text{Spur Level})]$$

Record the result on the test record. Compare the result to the specification.

Note



The odd harmonics will normally be higher than the even harmonics.

11. Repeat steps 8 through 10 for each of the spurs and spectrum analyzer frequencies in table 2-12. Change the spectrum analyzer reference level as indicated in the table.

Table 2-12. Spectrum Analyzer Frequencies and Line Spur Frequencies and Harmonics

Line Spur Harmonic	Line Spur Frequency (Hz)	Spectrum Analyzer Frequency (Hz)	Reference Level (dBm)
2	120	6,990,000,120	-50
3	180	6,990,000,180	-50
4	240	6,990,000,240	-50

12. For synthesizers capable of frequencies down to 10 MHz, set the synthesizer and spectrum analyzer to 2.3 GHz and repeat steps 6 through 11 for this frequency.

Related Adjustments

None

In Case of Difficulty

See "TROUBLESHOOTING" in the *Assembly-Level Repair* manual.

11. SINGLE SIDEBAND PHASE NOISE

Description and Procedure

This test provides two procedures. The first procedure uses a Phase Noise Measurement System and is the faster, more accurate method. The alternate procedure uses a high performance spectrum analyzer. This method degrades the measurement accuracy due to the addition of the spectrum analyzer's phase noise. Use the alternate procedure *only* if a Phase Noise Measurement System is not available.

1. Connect the equipment as shown in figure 2-12. Preset the equipment and let them warm up for at least one hour.

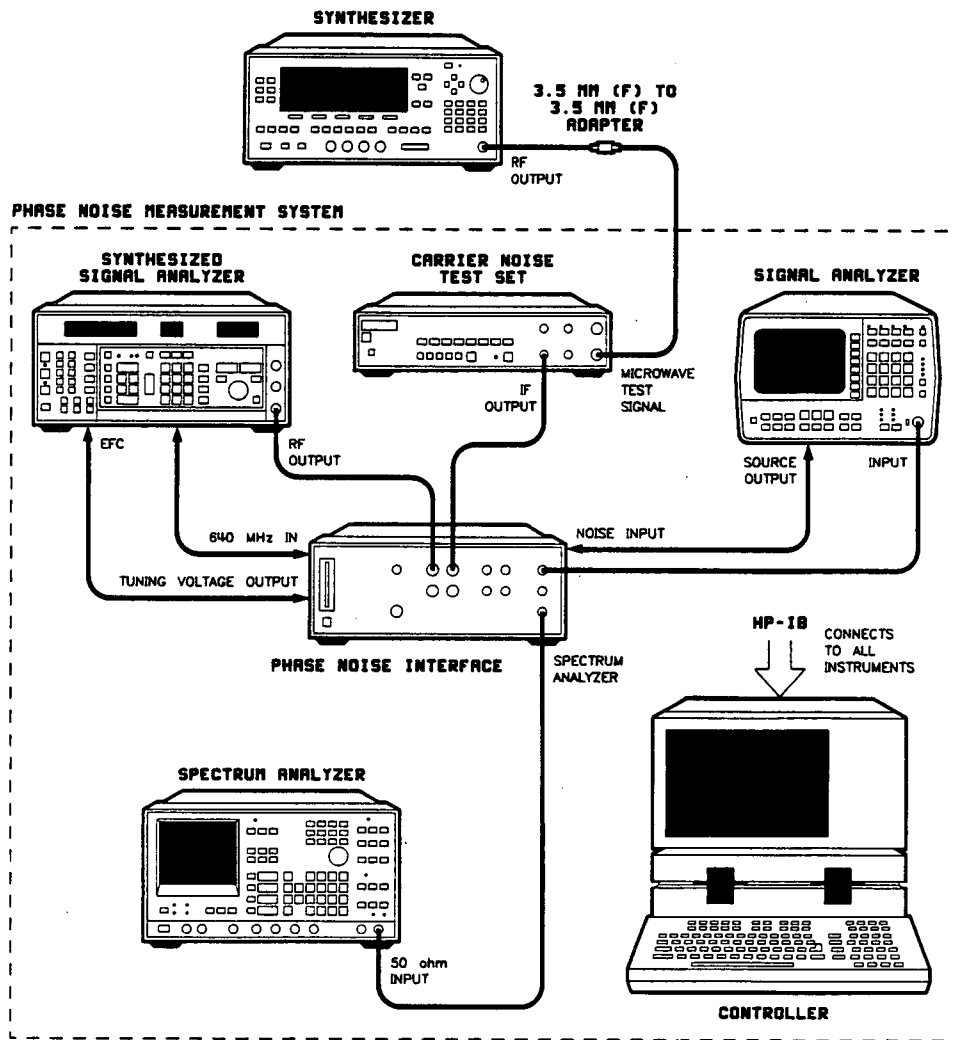

Figure 2-12. Single Sideband Phase Noise Test Setup

2. Load the measurement software for the Phase Noise Measurement System.

3. On the synthesizer, set:

CW **6.99** **GHz**

POWER LEVEL **0** **dBm**

4. On the Phase Noise Measurement System, set:

Measurement Type: phase locked
 Start Offset Freq: 100 Hz
 Stop Freq: 2 MHz
 Minimum Averages: 40
 Carrier Frequency: 6.99 GHz
 Det Input Freq: 50 MHz
 DUT: user's srce, man
 Ref Source: 8662A, SYS, VCO, EFC
 Ext Timebase: not in use
 Down Converter: 1179C, SYS
 HP 11848A LNA: out

Note



To avoid entering these parameters each time you perform this test, create a file on the Phase Noise Measurement System containing these parameters.

With these parameters entered, the software automatically sets the remaining parameters. Table 2-13 shows the complete set of parameters.

Table 2-13. Phase Noise Measurement System Parameters

Measurement Type:	phase locked	K_VCO Method:	Measured
Start Offset Freq:	100 Hz	VCO Tune Constant:	82.33 Hz/V
Stop Freq:	2 MHz		
Minimum Averages:	40	Loop Suppression:	Verified
		Closed PLL BW:	150.5 Hz
Carrier Frequency:	6.99 GHz	Peak Tuning Range:	725.1 Hz
Det Input Freq:	50 MHz	Assumed Pole:	37.9 kHz
Entered K_VCO:	28 Hz/V	DUT:	user's srce, man
Center Voltage:	0V	Ref Source:	8662A, SYS, VCO, EFC
		Ext Timebase:	not in use
Tune-voltage Range:	± 10V	Down Converter:	11792C, SYS
Phase Detector:	5 to 1600 Mhz	HP 11848A LNA:	Out
K_Detector Method:	measured		
Detector Constant:	458.8 mV/Rad		

5. Follow the instructions on the controller to make the phase noise measurement.
6. At the message:

VERIFY BEATNOTE <1 MHZ

The dynamic signal analyzer has two traces. The sine wave shows the beatnote frequency in time domain (like an oscilloscope). The other trace is in the frequency domain (like a spectrum analyzer). Tune the signal generator for minimum sine wave frequency with the frequency domain signal near the left edge (0 Hz).

7. When the measurement is complete record the results on the test record and compare them to the specification.
8. Repeat steps 3 through 6 for the frequencies in table 2-14.

Table 2-14. Frequency Setting for Phase Noise Measurements

Synthesizer Frequency (GHz)	Phase Noise Measurement System	
	Carrier Frequency (GHz)	Detector Input (MHz)
2.23	2.23	310
18.0	18.0	720

Related Adjustments

Sampler Assembly

In Case of Difficulty

1. Line spurs may be present in the trace which exceed the phase noise specification. They should be ignored.
2. Be sure that the signal generator frequency (detector input) is tuned close enough that a zero beat can be found.
3. Note where the problem occurs (carrier frequency and offset frequency from the carrier) and see "TROUBLESHOOTING" in the *Assembly-Level Repair* manual.

ALTERNATE PROCEDURE – SINGLE SIDEBAND PHASE NOISE

Description and Procedure

This procedure uses a high performance spectrum analyzer. This method degrades the measurement accuracy approximately 3 dB due to the addition of the spectrum analyzer's phase noise. Use this procedure *only* if a Phase Noise Measurement System is not available.

1. Connect the equipment as shown in figure 2-13. Preset the equipment and let them warm up for at least one hour.

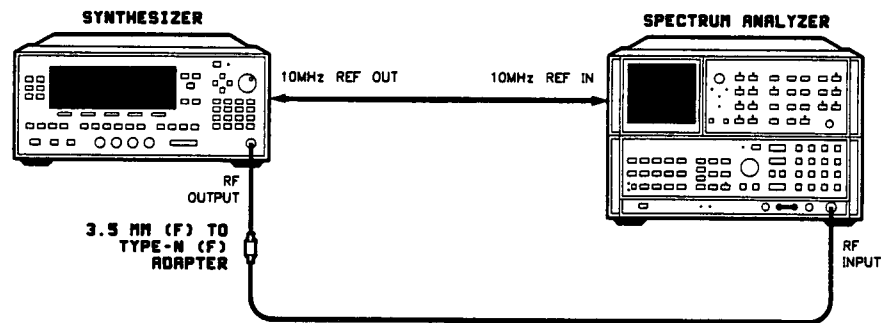

Figure 2-13. Alternate Phase Noise Test Setup

2. On the synthesizer, set:

CW 6.99 GHz
POWER LEVEL 0 dBm

3. On the spectrum analyzer, set:

Center Frequency:	Same frequency set in step 2
Frequency Span:	1 MHz
Reference Level:	0 dBm
Scale Log:	2 dB/Division
Resolution Bandwidth:	Auto
Video Bandwidth:	Auto
Sweep:	Auto
Video Averaging:	Off

4. On the spectrum analyzer:
Center the CW carrier signal on the display.
Reduce the frequency span to 100 Hz.
5. On the synthesizer, press **POWER LEVEL** and use the rotary knob to adjust the power level to place the signal peak at the 0 dBm reference level on the analyzer.
6. On the spectrum analyzer, set:

CF Step Size:	First CF step size in table 2-15
Reference Level:	-10 dBm
Frequency Span:	0 Hz
Scale Log:	10 dB/Division
Marker:	Noise level measurement
Center Frequency:	Increase (step up) by CF step size
7. After several sweeps, record the worst-case marker noise measurement (dBc/Hz) on the test record for the carrier offset frequency (from table 2-15) and compare it to the specification.
8. On the spectrum analyzer, change the CF step size to each of the settings in table 2-15 (to achieve the associated frequency offset from the carrier), step up the center frequency, and then repeat step 7.

Table 2-15. CF Step Size and Carrier Offset Frequencies

CF Step Size	Carrier Offset Frequency
100 Hz	100 Hz
900 Hz	1 kHz
9.1 kHz	10 kHz
90 kHz	100 kHz

9. On the spectrum analyzer, repeat steps 2 through 8 for synthesizer CW frequencies of 2.23 GHz and 18 GHz.

Related Adjustments

Sampler Assembly

In Case of Difficulty

This method of measuring phase noise introduces potential errors due to the addition of the spectrum analyzer's phase noise into the measurement. Use a Phase Noise Measurement System (the procedure preceding this one) and retest the failed frequencies.

12. PULSE MODULATION ON/OFF RATIO

Description and Procedure

Using a spectrum analyzer, the synthesizer's CW RF output power is measured both with pulse on and with pulse off. The difference in power is the pulse on/off ratio.

1. Connect the equipment as shown in figure 2-14. Preset all instruments and let them warm up for at least one hour.

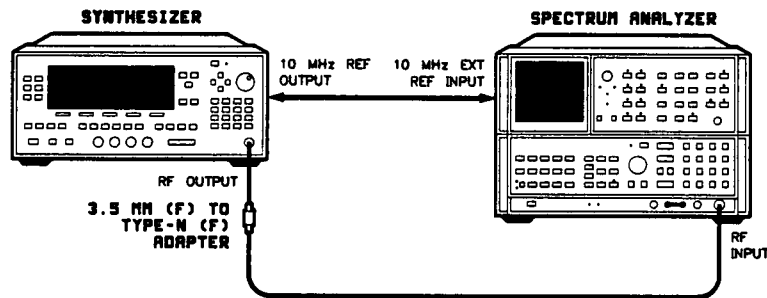

Figure 2-14. Pulse Modulation On/Off Ratio Test Setup

2. On the synthesizer, set:

CW The first center frequency in table 2-16

POWER LEVEL **0** **dBm**

FREQUENCY **MENU** **[Up/Dn Size CW]** **50** **MHz**

3. On the spectrum analyzer, set:

Center Frequency:	The same frequency set in step 2
Frequency Span:	100 Hz
Reference Level:	10 dBm
Marker:	On
Resolution Bandwidth:	10 Hz
Sweep Time:	50 ms
Center Frequency Step Size:	50 MHz

Table 2-16. Pulse On/Off Center Frequencies

Center Frequency (GHz)	Pulse On/Off Ratio
1.0*	_____
6.0	_____
9.0	_____
16.0	_____
* Not applicable for all models	

4. On the spectrum analyzer:
 - Tune center frequency to center the signal on the display.
 - Set the marker to highest peak.
 - Note the marker amplitude.
5. On the synthesizer, turn on the external pulse:
 - MOD** [**Pulse On/Off Extnl**] (asterisk on)
6. On the spectrum analyzer set the reference level to -60 dBm.
7. Set the marker to the highest peak and note the maximum marker amplitude.
8. The difference between the marker value in step 4 and the marker value in step 7 is the pulse on/off ratio. Record this value in table 2-16.
9. On the spectrum analyzer, set the reference level to 10 dBm.
10. On the synthesizer, turn off external pulse:
 - MOD** [**Pulse On/Off Extnl**] (asterisk off)
11. Repeat steps 2 through 10 for the remaining synthesizer and spectrum analyzer frequencies in table 2-16 with the following changes to step 7 when testing 6.0 GHz:
 - For a CW Frequency of 6.0 GHz:
 - a. Step the synthesizer and spectrum analyzer in 50 MHz steps from 6.0 to 7.0 GHz.
 - b. Note the frequency of the highest amplitude signal. Set the synthesizer and spectrum analyzer to this frequency.
 - c. Set the marker to the highest peak and note the maximum marker amplitude.
12. Record the worst case value from table 2-16 on the test record.

Related Adjustments

None

In Case of Difficulty

1. A failure can be caused by a spur. Move the center frequency of both the spectrum analyzer and the synthesizer by 1 kHz, and retest at that point. If the on/off ratio is bad, it will be bad over greater than a 100 kHz region.
2. See "TROUBLESHOOTING" in the *Assembly-Level Repair* manual.

13. PULSE PERFORMANCE

Description and Procedure

In this procedure, the synthesizer's RF output is downconverted in frequency so that an oscilloscope can measure the rise and fall times and make a comparison of pulsed and CW power level accuracy. Power level accuracy is checked at a 10 Hz pulse repetition rate to verify its operation at the slowest specified rate. The power amplifier ensures a sufficient signal level into the oscilloscope to make the measurement.

Rise and Fall Times

1. Connect the equipment as shown in figure 2-15. Preset the instruments and let them warm up for at least one hour.

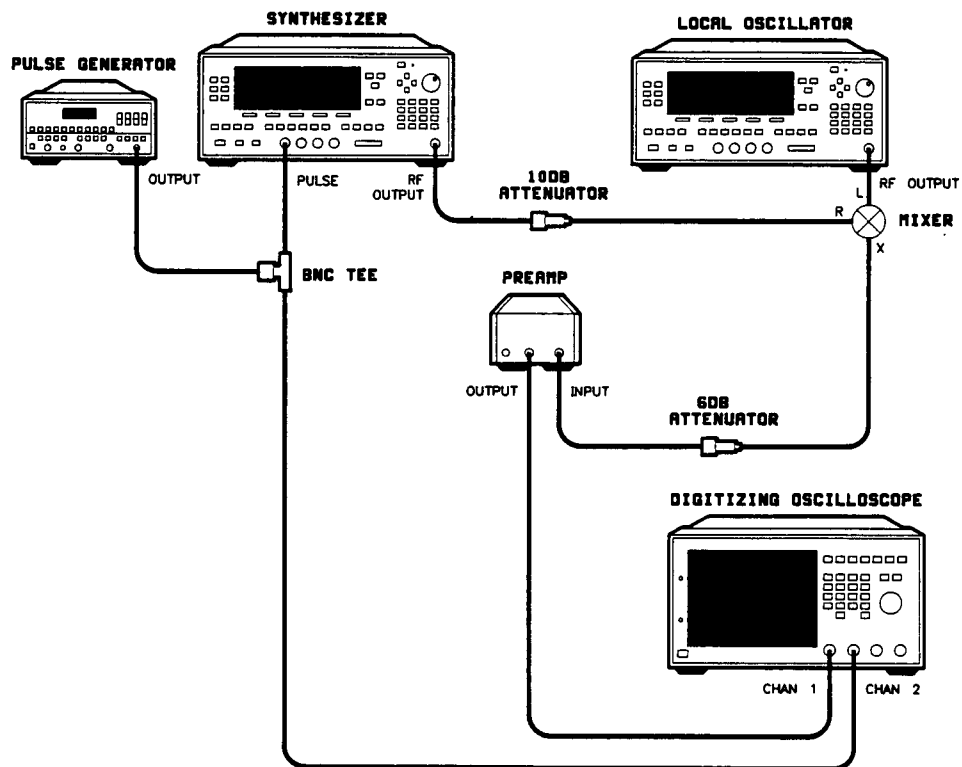

Figure 2-15. Pulse Performance Test Setup

2. On the synthesizer, set:

CW First synthesizer frequency in table 2-17

POWER LEVEL **-** **5** **dBm**

ALC [**Leveling Point Internal**] (asterisk on)

[**Leveling Mode Search**] (asterisk on)

3. On the local oscillator (HP 83620A), set:

Center Frequency: First LO frequency in table 2-17

Power Level: 10 dBm

RF Power: On

Table 2-17. Synthesizer and LO frequencies

Synthesizer Frequencies (GHz)	LO Frequencies (GHz)	Risetime	Falltime	Level Accuracy
1.9*	2.4*	_____	_____	_____
5.0	4.5	_____	_____	_____
9.0	8.5	_____	_____	_____
15.0	14.5	_____	_____	_____
* Not applicable for all models.				

Note



The CW frequencies checked provide a minimum verification of pulse performance. If pulse performance at a different frequency is important, repeat the test at that CW frequency.

4. On the pulse generator, set:

Pulse Width: 200 ns

Pulse Period: 10 us (100 kHz)

Pulse Level: 5V

Disable: LED off (enables pulse generator)

5. On the oscilloscope, set:

Channel 1:

Display	On
Volts/Division	100 mV
Offset	0V
Input Coupling	dc
Input Impedance	50 ohms

Channel 2:

Display	Off
---------	-----

Timebase:

Time/Division	10 ns
Delay	100 ns
Delay Reference	At center

Trigger:

Trigger Mode	Edge
Trigger Source	Chan 2
Trigger Level	2V

Display:

Display Mode	Repetitive
Averaging	On
Number of Averages	1
Screen	Single

Note



On the oscilloscope, turn the waveform math function on. Then use the waveform math maximum function to determine the pulse envelope when making the following measurements.

6. On the synthesizer, set:

MOD [*Pulse On/Off Extrl*] (asterisk on)

7. On the oscilloscope:

- Adjust the timebase delay to position the rising edge of the pulsed RF near the center of the display.
- Adjust the channel 1 volts/division and offset to obtain a 5 division signal level between the RF power off and the RF power on (see figure 2-16.)
- Adjust the channel 1 offset to move the the RF power off line one-half division below the nearest horizontal graticule (making the horizontal graticule cross the waveform at the 10% point.)
- Use the oscilloscope's delta T function to measure the time difference between the 10% and 90% risetime points on the envelope. (The 10% point of the risetime is where the pulse envelope crosses the graticule. The 90% point is 4 divisions up.) Record this value in table 2-17.

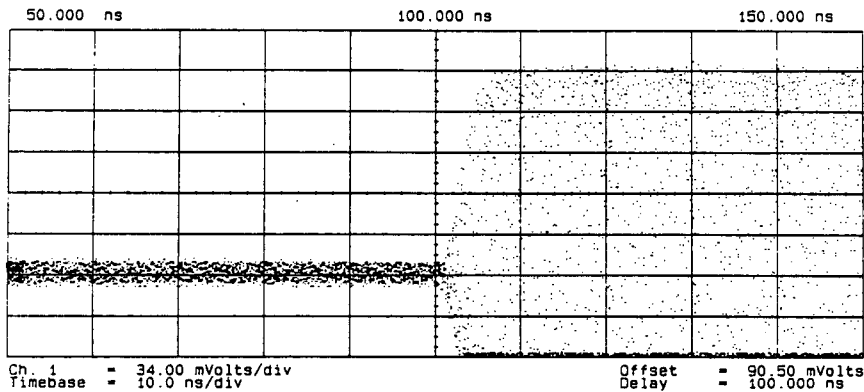

Figure 2-16. Signal Level between RF Power Off and On

8. Adjust the timebase delay to position the falling edge of the pulse near the center of the oscilloscope display.
9. Measure the falltime the same way as you measured the risetime (see step 7). Record this value in table 2-17.
10. Repeat steps 6 through 8 at each synthesizer and LO frequency in table 2-17.
11. Record each worst case risetime and falltime value from table 2-17 on the test record.

Pulse Leveling Accuracy

12. On the pulse generator, set:
 - Pulse Width: 1 us
 - Pulse Period: 0.1s (10 Hz)
 - Pulse Level: 5V
13. On the synthesizer, set:
 - CW First synthesizer frequency in table 2-17
 - POWER LEVEL dBm
 - ALC [Leveling Mode Normal]
 - MOD [Pulse On/Off Extnl] (asterisk on)

14. On the spectrum analyzer, set:

Center Frequency: First frequency in table 2-17

15. On the oscilloscope, set:

Channel 1:

Volts/Division 30 mV

Timebase: 100 ns

Time/Division

Delay Reference At left

Adjust the delay and timebase so that the pulse waveform takes up the entire display. Adjust the oscilloscope channel 1 offset to position the top of the pulse envelope near the center graticule.

16. On the synthesizer, turn off external pulse and set the power level to -5.3 dBm. Press:

[Pulse On/Off Extrl] (asterisk off)

POWER LEVEL **-** **5.3** **dBm**

17. Use the oscilloscope's waveform math maximum function to determine the peak power level (if the waveform math function was previously on, clear the display before executing this step.) Use the oscilloscope's delta V feature and position marker 1 at the center of the peak power as displayed by the math waveform (the width of the waveform is caused by noise in the system.) Leave the marker at that position.

18. Set the synthesizer's power level to -4.7 dBm. Press:

POWER LEVEL **-** **4.7** **dBm**

19. Clear the oscilloscope display and use the oscilloscope's waveform math maximum feature to determine the peak power level. Use the oscilloscope's delta V feature and position marker 2 at the center of the peak power as displayed by the math waveform.

20. On the synthesizer, set:

POWER LEVEL **-** **5** **dBm**

MOD **[Pulse On/Off Extrl]** (asterisk on)

21. Reset the oscilloscope waveform math feature to maximum and observe the peak pulse power. It should stay within the two delta V markers set in steps 14 and 17. Record the value in table 2-17 as Level Accuracy.

22. Repeat steps 11 through 20 at each synthesizer and LO frequency in table 2-17.

23. Record the worst case value from table 2-17 on the test record.

Related Adjustments

Pulse Delay

In Case of Difficulty

1. A noisy amplifier can cause a noisy trace that is too wide to measure. Substitute amplifiers to verify a problem with the amplifier.
2. If there is no change in amplification, the amplifier may be saturated (operating in compression). The 0.3 dB variation should be approximately equal on both sides. Try a lower synthesizer power level to get the amplifier out of saturation.
3. See "TROUBLESHOOTING" in the *Assembly-Level Repair* manual.

14. PULSE MODULATION VIDEO FEEDTHROUGH

Description and Procedure

In CW, at specified maximum leveled power, the synthesizer is pulse modulated using a pulse generator. The synthesizer's RF output is filtered (only the video feedthrough passes), amplified, and displayed on an oscilloscope. Because of the low amplitude of the video feedthrough, a preamplifier is used in the test setup; system gain must be considered when making this measurement.

When video feedthrough is expressed as a percentage, the following equation is used:

$$\text{Video feedthrough (\%)} = [(\text{video } V_p / \text{carrier } V_p) \times 100] / \text{video gain}$$

1. Preset all the instruments shown in figure 2-17 and let them warm up for at least one hour.
2. To achieve peak power, turn on RF peaking:

[USER CAL] **[Tracking Menu]** **[Peak RF Always]** (asterisk on)

3. Connect the equipment as shown in figure 2-17 with the pulse generator connected directly to channel 1 of the oscilloscope (A).

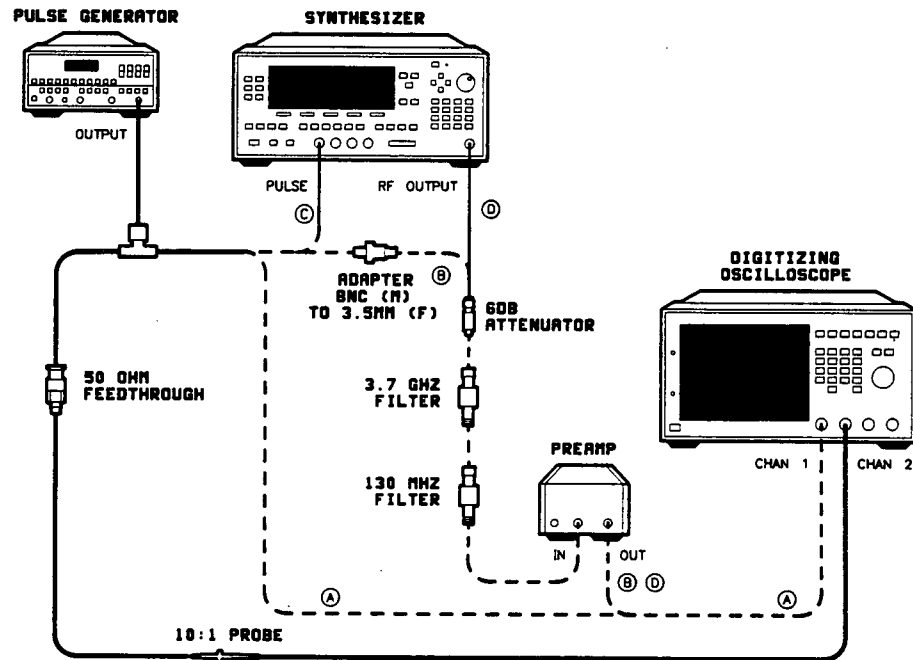

Figure 2-17. Video Feedthrough Test Setup

System Calibration

Note



The pulse generator output level can be affected by loading. Leave the pulse generator connected to the oscilloscope's channel 2 (through the BNC tee) as you set the output level.

4. On the oscilloscope, set:

Channel 1:

Display	On
Volts/Division	50 mV
Offset	0V
Input Coupling	dc
Input Impedance	50Ω

Channel 2:

Display	Off
---------	-----

Timebase:

Time/Division	20 ns
Delay	0s
Delay Reference	At center

Trigger:

Trigger Mode	Edge
Trigger Source	Channel 1
Trigger Level	0.05V
Trigger Slope	Positive

Display:

Display Mode	Repetitive
Averaging	On
Number of Averages	16

5. On the pulse generator, set:

Pulse:	Selected
Pulse width:	10 ns
Frequency:	2 MHz (500 ns)
Offset:	0V

6. On the pulse generator, set the pulse amplitude for a reading of 0.1V on the oscilloscope.

Video Gain

7. Connect the pulse generator to the oscilloscope's channel 1 through the attenuator, filters, and amplifier (B).

8. On the oscilloscope, set:

Channel 1:

Volts/Division 0.2V
 Offset -0.3V
 Input Coupling dc
 Input Impedance 50Ω

Trigger:

Trigger Mode Edge
 Trigger Source Channel 1
 Trigger Level -0.4V
 Trigger Slope Negative

9. On the oscilloscope, note the pulse amplitude: _____ Vp

10. Calculate the video gain:

$$\begin{aligned} \text{Video gain} &= \frac{\text{system Vp (from step 7)}}{\text{pulse generator Vp}} \\ &= \frac{\text{system Vp}}{0.1 \text{ Vp}} \end{aligned}$$

Low Band Video Feedthrough (not applicable for all models)

11. Connect the pulse generator output to the synthesizer's pulse input (C).

12. Connect the synthesizer to the oscilloscope's channel 1 through the attenuator, filters, and amplifier (D).

13. On the synthesizer, set:

CW First CW frequency in table 2-18.

ALC [Leveling Mode Search].

POWER LEVEL 10 dBm .

MOD [Pulse On/Off Extrnl] (asterisk on).

Table 2-18. Low Band Video Feedthrough Frequencies

Synthesizer CW Frequency (GHz)	Video Feedthrough (%)	
	+ 10 dBm	Maximum Levelled Power
0.4	_____	_____
0.7	_____	_____
1.0	_____	_____
1.3	_____	_____
1.6	_____	_____
1.9	_____	_____
2.2	_____	_____

14. On the oscilloscope, set:

Channel 1:

Display	On
Volts/Division	0.010V
Offset	0V
Input Coupling	dc
Input Impedance	50 Ω

Channel 2:

Display	Off
Volts/Division	1V
Offset	2V

Timebase:

Time/Division	200 ns
Delay	400 ns
Delay Reference	At center

Trigger:

Trigger Mode	Edge
Trigger Source	Channel 2
Trigger Level	1V
Trigger Slope	Positive

Display:

Display Mode	Repetitive
Averaging	On
Number of averages	64

15. On the pulse generator, set:

Pulse width:	500 ns
Frequency:	200 kHz (5 μ s)
Offset:	0V
Amplitude:	5V

16. On the oscilloscope, note the maximum voltage from the baseline (see figure 2-18). Video feedthrough (Vp) = _____ Vp

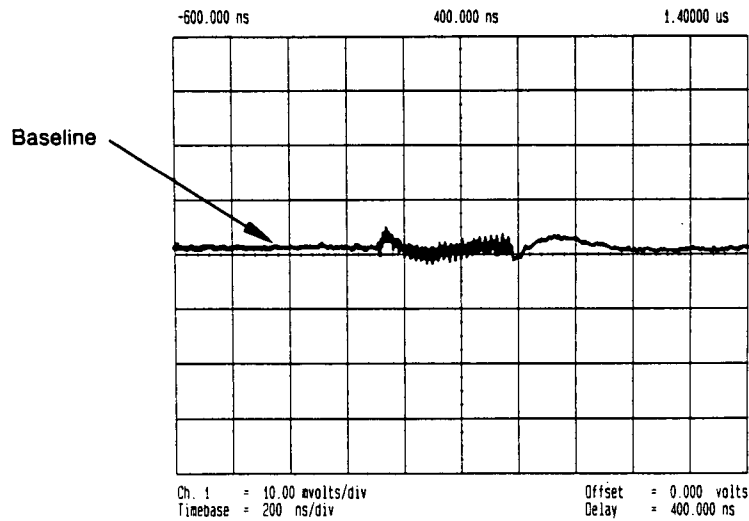

Figure 2-18. Measuring Maximum Voltage from the Baseline Video Feedthrough

- Using the video gain from step 10, the video feedthrough (V_p) from step 16, and the carrier voltage from table 2-19, calculate the video feedthrough as a percent of carrier power:

$$\text{Video feedthrough (\%)} = [(\text{video } V_p / \text{carrier } V_p) \times 100] / \text{video gain}$$

Table 2-19. Power Level Conversions to Volts Peak

Synthesizer Maximum Specified Power (dBm) Into 50Ω	Peak Carrier Voltage ¹ (V)
10.0	1.00
15.5	1.88
17.0	2.24
17.5	2.37
20.0	3.16

1. Peak Carrier Voltage = $10^{\frac{(\text{PdBm} - 10)}{20}}$

- Record the video feedthrough (%) in table 2-18.
- Repeat steps 16 through 18 for the remaining CW frequencies in table 2-18.
- On the test record, record the largest video feedthrough value (+10 dBm) noted on table 2-18.

21. Repeat steps 16 through 18 with the synthesizer power level set to maximum specified leveled power for all of the CW frequencies in table 2-18.
22. On the test record, record the largest video feedthrough value (maximum leveled power) noted on table 2-18.

High Band Video Feedthrough

Note



Typically, high band video feedthrough is so small that it is difficult to measure. Use the following procedure to verify that the video feedthrough is negligible.

23. On the oscilloscope, set channel 1 to 1 mV/div.
24. On the synthesizer, set the first CW frequency in table 2-20.

Table 2-20. High Band Video Feedthrough Frequencies

Frequency (GHz)	Video Feedthrough (Vp)
5.0	_____
10.0	_____
15.0	_____
20.0	_____

25. On the oscilloscope, note the maximum voltage from the baseline. Video feedthrough
(Vp) = _____ Vp

Record this value in table 2-20.

26. Repeat steps 23 and 24 for each value in table 2-20.
27. Record the worst case value from table 2-20 on the test record.

Related Adjustments

None

In Case of Difficulty

See "TROUBLESHOOTING" in the *Assembly-Level Repair* manual.

15. AM ACCURACY

Description and Procedure

This procedure measures the AM accuracy of the synthesizer. The local oscillator and mixer are used to down convert the synthesizer frequency to the frequency range of the measuring receiver (an HP 11793A Microwave Converter can be substituted for the mixer). The function generator provides AM modulation. The function generator signal level is adjusted for 30% AM as measured by the measuring receiver. The function generator signal level is checked for accuracy. A DVM may be necessary to measure the function generator output.

1. Turn on the equipment shown in figure 2-19. Preset the instruments and let them warm up for at least one hour.
2. On the measuring receiver:
Calibrate and store the AM calibration factor.
3. Connect the equipment as shown in figure 2-19.

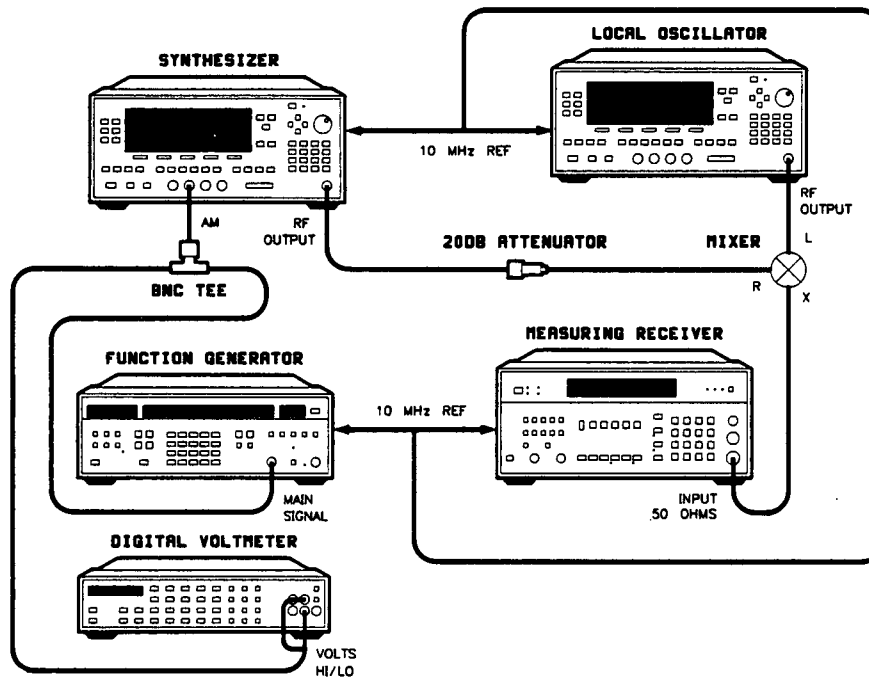

Figure 2-19. AM Accuracy Test Setup

4. On the synthesizer, set:

CW **5** **GHz**

POWER LEVEL **10** **dBm**

USER CAL [**AM Cal Menu**] [**AM BW Cal Always**] (asterisk on)

5. On the local oscillator, set:

CW Frequency: 5.1 GHz

RF: On

Power Level: 10 dBm

6. On the function generator, set:

Function: Sinewave

Frequency: 1 kHz

Amplitude: 600 mV p-p

DC Offset: 0 mV

7. On the measuring receiver, set:

HP Filter: 300 Hz

LP Filter: 3 kHz

Measurement: AM

Detector: Peak $\pm/2$ (both on)

Automatic Operation

8. On the synthesizer, turn on AM modulation. Set:

MOD [**AM On/Off 100%/V**] (asterisk on)

9. Set the function generator amplitude for 30% AM modulation depth as indicated by the measuring receiver.
10. Record the function generator output as a percent of 600mV p-p on the test record and compare it to the specification.

Related Adjustments

Modulator Offset and Gain

In Case of Difficulty

1. The AM input impedance is internally selectable to either 50 Ω or 2k Ω (the factory-set value is 50 Ω). If the AM input is set for 2k Ω , and the function generator requires a 50 Ω system, use a DVM to measure the AM input signal level while it is connected to the synthesizer.
2. See "TROUBLESHOOTING" in the *Assembly-Level Repair* manual.

16. AM BANDWIDTH

Description and Procedure

This test verifies that the peak RF output power does not vary more than a specified amount over the specified amplitude modulation rate frequency range. The spectrum analyzer with the tracking generator operates as a network analyzer to measure the flatness. Flatness errors associated with the tracking generator and spectrum analyzer are calibrated out of the measurement.

1. Connect the equipment as shown in figure 2-20 with the tracking generator output connected to the 50 ohm input of the spectrum analyzer. Press **PRESET** and let the equipment warm up for at least one hour.

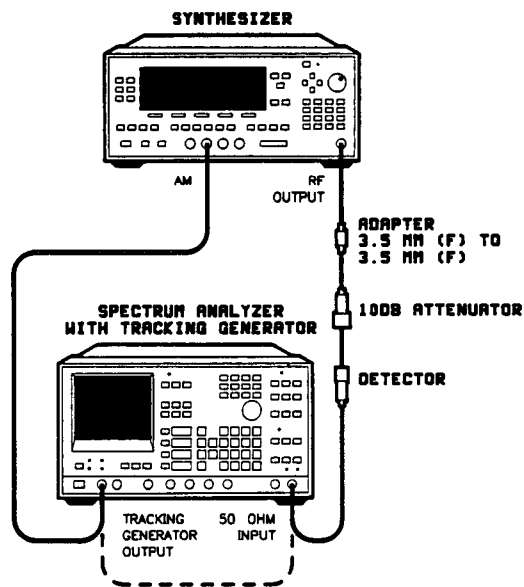

Figure 2-20. AM Bandwidth Test Setup

2. On the spectrum analyzer, set:
 - Start Frequency: 5 kHz
 - Stop Frequency: 100 kHz
 - Manual Sweep: 10 kHz
 - Scale Log: 1 dB/Division
 - Range: 5 dBm
 - Tracking Generator Amplitude: Maximum (600-700 mV p-p)
3. On the spectrum analyzer, clear trace A memory. Change the reference level, using the RPG knob, to position the trace on the center horizontal graticule.
4. Set the spectrum analyzer to continuous sweep. When a full sweep is completed, store trace A into trace B memory. Then display A minus B (turning off trace B). A straight line should be displayed.

The spectrum analyzer is now calibrated.

5. Connect the tracking generator output to the synthesizer's AM input and connect the synthesizer's RF output through the crystal detector to the spectrum analyzer's 50 ohm input.
6. On the synthesizer, set:
 - USER CAL** [**AM CAL MENU**] [**AM BW CAL Always**] (asterisk on)
 - CW** First synthesizer frequency in table 2-21
 - POWER LEVEL** 13 dBm
 - MOD** [**AM On/Off 100%/V**] (asterisk on)

Table 2-21. Synthesizer Frequencies

Synthesizer Frequencies (GHz)	Maximum Difference
1.5*	_____
5.0	_____
9.0	_____
18.0	_____
* Not applicable for all models	

7. On the spectrum analyzer, clear and write to trace A. Change the reference level to center the trace on the display. If an over range occurs, turn the RPG knob in the opposite direction.

The display now shows the synthesizer AM flatness from 5 kHz to 100 kHz.

8. Use the marker offset feature of the spectrum analyzer to measure AM flatness. Set:

MANUAL **100** **kHz** **OFFSET** (light on) **ENTER OFFSET** **MARKER**

Use the RPG knob to tune the offset over the full frequency range. The offset amplitude relative to 10 kHz is displayed in the upper right side of the CRT.

Determine the maximum and minimum deviation points from the 10 kHz reference. Record the value of the difference in table 2-21.

9. Repeat steps 6 through 8 for the remaining frequencies in table 2-21.
10. Record the worst case value from table 2-21 on the test record.

Related Adjustments

None

In Case of Difficulty

See "TROUBLESHOOTING" in the *Assembly-Level Repair* manual.

17. AM DYNAMIC RANGE

Description and Procedure

In this procedure, a function generator is used to provide a dc voltage to the synthesizer's AM input. The synthesizer is set to 0 dBm output power. AM is enabled and a dc voltage is applied. The dc voltage is set for maximum AM without an overmodulation indication to drive the synthesizer's modulator to the edge of distortion. The output power is measured with a power meter. A measurement is made in 1 GHz steps across the synthesizer's frequency range. This equipment lets you measure down to -30 dBm. If you reach this level before the synthesizer overmodulates, the power meter will indicate an under range measurement.

This procedure is repeated using the deep AM function in the search ALC mode. A spectrum analyzer is used in place of the power meter to make the deep AM measurement. This equipment allows you to measure down to approximately -65 dBm. If your synthesizer does not overmodulate by this point, and you wish to measure the power level just before overmodulation, use a power supply to increase the dc voltage supply to the AM input.

Caution



Do not exceed -15 V dc to the AM input or damage will occur.

1. Preset the instruments shown in figure 2-21 and let them warm up for at least one hour.

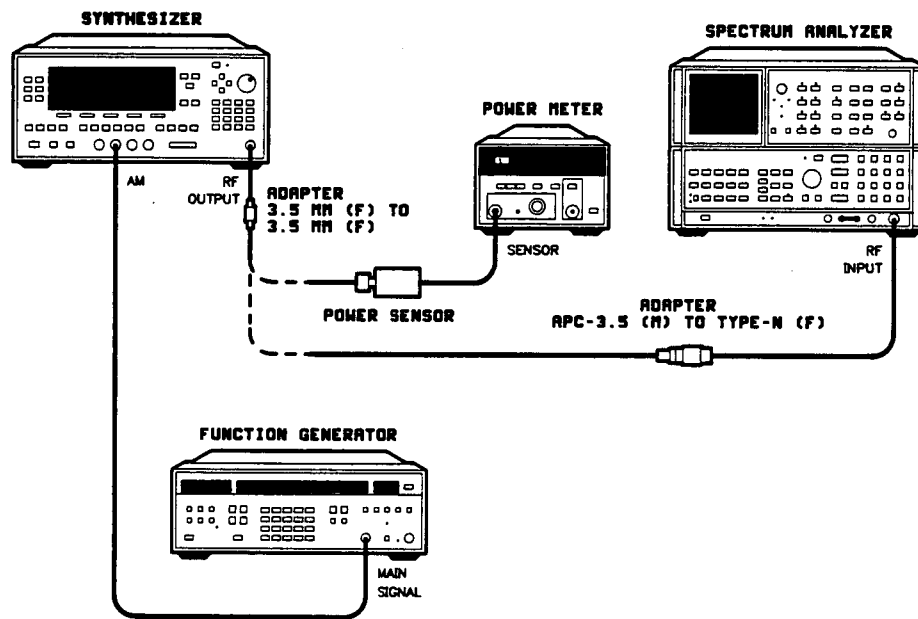

Figure 2-21. AM Dynamic Range Test Setup

2. To achieve peak power, turn on RF peaking. Set:
 (asterisk on)
3. Zero and calibrate the power meter/sensor.
4. Connect the equipment as shown in figure 2-21 with the power sensor connected to the synthesizer's RF OUTPUT.
5. On the synthesizer, set:
 (Set to 2 GHz for synthesizers with lowest start frequency of 2 GHz)
 FREQUENCY
 POWER (option 001 only)

 Verify that all modulation is off. (No asterisks next to key labels.)
6. On the power meter, set:
 Mode: dBm
 Cal Factor %: Cal factor corresponding to the synthesizer's CW frequency
7. On the function generator, turn off all waveforms and set:
 dc Offset: -1.5 V dc

Normal AM Dynamic Range

8. On the synthesizer, turn on AM modulation to 10 dB/V:
 (asterisk on)
9. Decrease the function generator output just until the OVERMOD message turns on. Then increase the signal until the OVERMOD message turns off. (The more negative the signal applied to the modulator is, the more the RF output level decreases.)
10. Wait for the power meter to settle then note the power meter reading. If the power meter reads under range, record < -30 dB on the test record.

Power Meter Reading

1 GHz _____	11 GHz _____
2 GHz _____	12 GHz _____
3 GHz _____	13 GHz _____
4 GHz _____	14 GHz _____
5 GHz _____	15 GHz _____
6 GHz _____	16 GHz _____
7 GHz _____	17 GHz _____
8 GHz _____	18 GHz _____
9 GHz _____	19 GHz _____
10 GHz _____	20 GHz _____

11. Repeat steps 9 and 10 from 2 to 20 GHz, in 1 GHz steps. Change the power meter cal factor % as required.
12. Record the worst case value from step 10 on the test record.

Deep AM Dynamic Range

13. Disconnect the power sensor from the synthesizer and connect the spectrum analyzer as shown in figure 2-21.

14. On the synthesizer, set:

CW **1** **GHz** (Set to 2 GHz for synthesizers with lowest start frequency of 2 GHz)

[AM On/Off 10dB/V] (asterisk off)

POWER LEVEL **-** **15** **dBm**

15. On the spectrum analyzer, set:

Center Frequency: 1 GHz

Frequency Span: 1 MHz

CF Step Size: 1 GHz

Reference Level: 5 dBm

Scale Log: 5 dB/Division

16. Center the signal on the spectrum analyzer with the center frequency control.

17. On the synthesizer, set:

[AM On/Off 10dB/V] (asterisk on)

[Deep AM] (asterisk on)

18. Change the spectrum analyzer reference level to -40 dBm.

Note



Make the following measurements as quickly as possible since the signal amplitude is subject to drift when you use deep AM at low levels.

19. Set the function generator for the minimum signal output without causing an OVERMOD message on the synthesizer.

20. Record the RF signal level on the test record and verify that it is less than the specification.

RF Signal Level

1 GHz _____	11 GHz _____
2 GHz _____	12 GHz _____
3 GHz _____	13 GHz _____
4 GHz _____	14 GHz _____
5 GHz _____	15 GHz _____
6 GHz _____	16 GHz _____
7 GHz _____	17 GHz _____
8 GHz _____	18 GHz _____
9 GHz _____	19 GHz _____
10 GHz _____	20 GHz _____

21. On the synthesizer, turn off modulation. Select:

[AM On/Off 10dB/V] (asterisk off)

22. Step the synthesizer and spectrum analyzer CW and center frequencies in 1 GHz steps. Turn modulation back on and repeat steps 19 through 21 until 20 GHz is measured.

23. Record the worst case value from step 20 on the test record.

Related Adjustments

Modulator Offset and Gain

In Case of Difficulty

1. Make sure that the most negative voltage *without* an OVERMOD message is applied.
2. See "TROUBLESHOOTING" in the *Assembly-Level Repair* manual.

18. FM ACCURACY

Description and Procedure

Use this procedure to measure the FM accuracy of the synthesizer. With the synthesizer set to an FM sensitivity of 10 MHz/V, and the function generator providing an FM modulation index of 2.404, the RF output should be a null. You then adjust the function generator amplitude for the Bessel null and record the difference between signals.

Note



Since the modulation frequency is 1 MHz, this procedure relies on the voltage-setting accuracy of the function generator (the frequency is too high for a DVM, and an oscilloscope is not accurate enough.)

1. Connect the equipment as shown in figure 2-22. Preset all instruments and let them warm up for at least one hour.

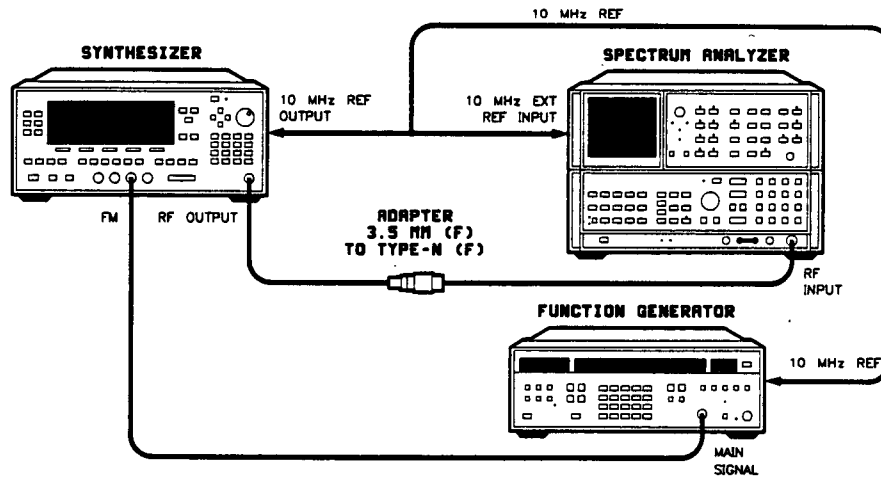

Figure 2-22. FM Accuracy Test Setup

2. To achieve peak power, turn on RF peaking. Select:
USER CAL [Tracking Menu] [Peak RF Always] (asterisk on)
3. On the synthesizer, set:
CW First synthesizer frequency in table 2-22
POWER LEVEL Set the specified maximum leveled power

Table 2-22. Synthesizer Frequencies

Synthesizer Frequencies (GHz)	Error %
1.0*	_____
5.0	_____
10.0	_____
16.0	_____
20.0	_____
* Not applicable for all models.	

4. On the function generator, set:

Function: Sine wave
 Frequency: 1 MHz
 Amplitude: 480.8 mV p-p (169.96 mV rms)
 DC Offset: 0 V

5. On the spectrum analyzer, set:

Reference Level: 20 dBm
 Attenuator: Auto
 Center Frequency: Same frequency as in step 3
 Frequency Span: 50 kHz
 Resolution Bandwidth: 3 kHz
 Video Bandwidth: 1 kHz
 Sweep Time: Auto
 Sweep: Continuous

6. Center the signal on the spectrum analyzer display using the center frequency function.

7. Turn on the synthesizer modulation. Set:

MOD [FM On/Off AC] (asterisk on).

8. Adjust the function generator amplitude to minimize the amplitude of the signal on the spectrum analyzer.

9. Calculate the percentage of error as follows:

$$\text{Error (\%)} = 480.8 \text{ mV p-p} - \text{New Amplitude} / 480.8 \text{ mV p-p} \times 100.$$

10. Record the error in table 2-22.

11. Turn off the synthesizer FM modulation. Select:
[FM On/Off AC] (asterisk off).
12. Repeat steps 6 through 11 at the synthesizer (and spectrum analyzer) frequencies in table 2-22.
13. Record the worst case value from table 2-22 on the test record.

Related Adjustments

FM Gain

In Case of Difficulty

See "TROUBLESHOOTING" in the *Assembly-Level Repair* manual.

19. FM BANDWIDTH

Description and Procedure

Use this procedure to verify that the RF output power does not vary more than a specified amount over the specified frequency modulation rate frequency range. A low frequency spectrum analyzer with a tracking generator operates as a network analyzer to measure the FM flatness. Flatness errors associated with the tracking generator and spectrum analyzer are calibrated out of the measurement. Flatness errors due to the power splitter and microwave amplifier are minimized by external leveling at the amplifier. The delay line discriminator is used to demodulate the FM from the RF carrier. It also provides an input to the spectrum analyzer that is equivalent to the tracking generator frequency and proportional in power to the synthesizer RF output.

The delay line discriminator is formed by driving a mixer with a modulated carrier into the LO port, and a delayed carrier into the RF port. The delay is produced with a cable of approximately 3 feet in length. With this setup, the mixer responds to phase differences between the two inputs. The cable has a constant time delay and, as the carrier frequency is frequency-modulated, a linear phase shift occurs between the mixer inputs. Since the mixer inputs are in quadrature, the mixer operates as a phase detector that amplitude tracks the RF input (synthesizer power) and has an output frequency corresponding to the FM rate (tracking generator frequency).

1. Connect the equipment as shown in figure 2-23 with the tracking generator output connected to the channel 1 input of the oscilloscope (A). A DVM can be used in place of the oscilloscope for RMS measurements. Preset all the equipment and let them warm up at least one hour.

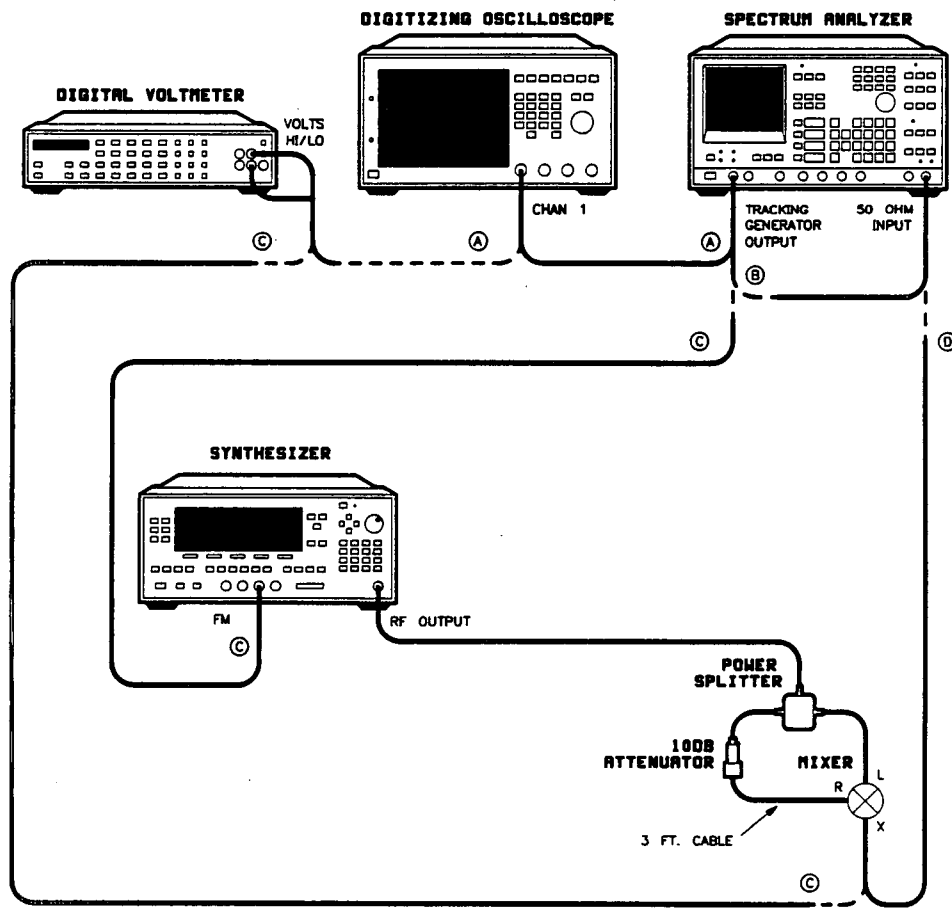

Figure 2-23. FM Bandwidth Test Setup

2. To achieve peak power, turn on RF peaking. Set:

USER CAL [**Tracking Menu**] [**Peak RF Always**] (asterisk on)

3. On the spectrum analyzer, set:

Center frequency: 100 kHz

Frequency Span: 0 Hz

Set the spectrum analyzer tracking generator to 200 mV p-p (141.4 mV rms). Choose the alternate detector if your tracking generator has an alternate detector that improves the low-end flatness.

4. Connect the tracking generator output to the 50 ohm input of the spectrum analyzer (B). On the spectrum analyzer, set:

Start Frequency: 50 kHz

Stop Frequency: 5 MHz

Resolution Bandwidth: 10 kHz

Video Bandwidth: 1 kHz

Sweep: Continuous

Scale Log: 2 dB/Division

Range: 5 dBm

5. On the spectrum analyzer, clear trace A memory. Change the reference level, using the RPG knob, to position the trace on the center horizontal graticule.

6. When a full sweep is completed, store trace A into trace B memory. Then display A minus B (turning off trace B). A straight line should be displayed.

Find Quadrature

7. Connect the tracking generator output to the synthesizer's FM input and connect the mixer's IF output to the DVM's VOLTS HI/LO input (C).

8. On the synthesizer, set:

CW First synthesizer frequency in table 2-23

ALC [**Leveling Point ExtDet**] [**Coupling Factor**] - **16** **dB**

POWER LEVEL **16** **dBm**

Table 2-23. Synthesizer Frequencies

Synthesizer Frequencies (GHz)	Maximum Difference
1.5*	_____
5.0	_____
9.0	_____
18.0	_____
* Not applicable for all models.	

9. On the spectrum analyzer, set:

Center Frequency: 100 kHz
 Frequency Span: 0 Hz

10. On the synthesizer, press **(CW)** and use the left arrow key to position the cursor in the 1 MHz position (one digit left of the decimal point). Use the rotary knob to adjust the CW frequency for 0V on the DVM.

DC FM Flatness (Unlocked)

11. Move the mixer's IF output from the DVM to the spectrum analyzer's 50Ω input.

12. On the synthesizer, turn on FM DC. Select:

(MOD) [FM On/Off DC] (asterisk on)

13. On the spectrum analyzer, set:

Start Frequency: 50 kHz
 Stop Frequency: 5 MHz
 Scale Log: 2 dB/Division
 Trace: A - B

Change the reference level to center the trace on the display.

14. On the spectrum analyzer, clear trace A memory. Change the reference level, using the RPG knob, to position the trace on the center horizontal graticule. If an over-range occurs, turn the knob in the opposite direction.

15. The display now shows the synthesizer FM flatness from dc to 5 MHz.

Use markers to find the maximum and minimum points on the trace. Record the value of the difference in table 2-23.

16. Repeat steps 7 through 15 at the synthesizer frequencies in table 2-23.

17. Record the worst case value from table 2-23 on the test record.

Related Adjustments

FM Gain

In Case of Difficulty

See "TROUBLESHOOTING" in the *Assembly-Level Repair* manual.

20. MAXIMUM FM DEVIATION

Description and Procedure

In this procedure, the synthesizer's RF output is monitored directly on a spectrum analyzer for low FM rates. The FM amplitude is increased until the maximum deviation exceeds the specification.

For higher FM rates, the FM rate is set so that a Bessel null occurs when the RF peak deviation equals the specification. The modulation amplitude is increased in order to pass through the correct Bessel null for the FM rate used and the peak deviation specified.

1. Connect the equipment as shown in figure 2-24. Preset all the instruments and let them warm up for at least one hour.

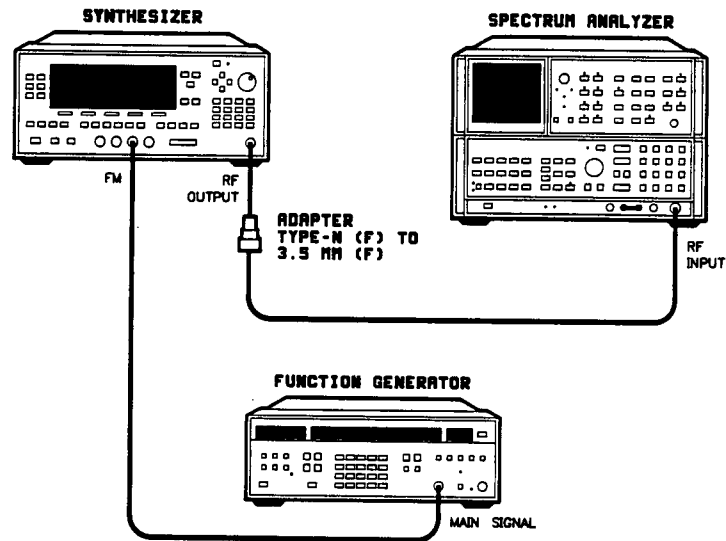

Figure 2-24. Maximum FM Deviation Test Setup

DC FM (≤ 100 Hz)

2. On the synthesizer, set:

CW **1** **GHz**

FREQUENCY **MENU** **[Up/Dn Size CW]** **1** **GHz**

USER CAL **[Tracking Menu]** **[Peak RF Always]** (asterisk on)

3. On the spectrum analyzer, set:

Center Frequency: 1 GHz
Frequency Span: 187.5 MHz
Center Frequency Step Size: 1 GHz
Reference Level: 10 dBm

4. On the function generator, set:

Function: Sinewave
Frequency: 100 Hz
Amplitude: Minimum

5. Center the signal on the spectrum analyzer display by adjusting the center frequency. Set the spectrum analyzer to maximum hold.

6. On the synthesizer, set:

MOD *[FM On/Off DC]* (asterisk on)

Note



The function generator must be capable of supplying > 16 V p-p into 50Ω to obtain sufficient FM deviation for this step.

7. Increase the function generator amplitude until the width of the signal displayed exceeds eight divisions on the spectrum analyzer. Record PASS if the signal exceeds eight divisions with no unlock or overmod message on the synthesizer. Record FAIL if not.

1 GHz _____ 9 GHz _____
5 GHz _____ 18 GHz _____

8. On the synthesizer, set:

[FM On/Off DC] (asterisk off)

9. On the spectrum analyzer, clear and write to trace A.

10. Decrease the function generator amplitude to minimum.

11. Repeat steps 5 through 10 for synthesizer and spectrum analyzer frequencies of 5, 9, and 18 GHz.

12. Circle PASS on the test record if all the results in step 7 are PASS. If not, circle FAIL on the test record.

AC FM (at 100 kHz)

Note



Maximum FM deviation for a 100 kHz rate is limited to a modulation index of 5 times n, where n = frequency band. The modulation index is equivalent to deviation/rate.

13. On the synthesizer, set:

CW **1** **GHz**

14. On the spectrum analyzer, set:

Center frequency: 1 GHz
Frequency Span: 1 MHz
Reference Level: 10 dBm

Clear all data from the display.

15. Center the signal on the analyzer display.

16. On the function generator, set:

Function: Sine wave
Frequency (FM Rate): 100 kHz
Amplitude: 1 mV

17. On the synthesizer, set:

MOD **[FM on/Off AC]** (asterisk on)

This activates FM sensitivity. Use the down arrow key to set FM sensitivity to 1.00 MHz/V.

18. On the function generator, set:

Amplitude (Calculated Null Voltage): 271 mV_{rms}

Use the **AMPTD CAL** key to do an amplitude calibration. Use the arrow keys to adjust the amplitude to achieve a null of the 1st sideband (Sideband Nulled).

Note



The sidebands may not respond to increases and decreases of the FM Input Voltage symmetrically. In this case, take the average of the voltages that cause the lower sideband and upper sideband to null.

19. Record the Actual Null Voltage in the space provided in table 2-24.

20. Calculate the actual FM sensitivity using the formula:

Actual FM Sensitivity = (Calculated Null Voltage/Actual Null Voltage) (Set FM Sensitivity)

Record this value in the space provided in table 2-24.

21. On the function generator, increase the amplitude (FM input voltage) until the synthesizer displays the UNLOCK message. Decrease the FM Input Voltage just until the UNLOCK message turns off.

20. Record the FM input voltage in the Maximum FM Voltage column of table 2-24.

21. Calculate the maximum FM deviation using the formula:

Max FM Deviation = (Actual FM Sensitivity)[(1.414)(Max FM Voltage)]

22. Record the maximum FM deviation in the appropriate column of the test record.
23. Repeat steps 13 through 22 for all the synthesizer settings indicated in table 2-24.

Note



Remember to use the set FM sensitivity as a multiplier when calculating the actual FM sensitivity.

Table 2-24. FM Deviation Frequencies and Settings

Synthesizer Settings		Spectrum Analyzer Settings		Sideband Nulled	Function Generator Settings		Readings and Calculations		
CW Frequency (GHz)	FM Sensitivity (MHz/Volt)	Center Frequency (GHz)	Frequency Span (MHz)		Frequency FM Rate (MHz)	Amplitude Calculated Null Voltage (mV _{rms})	Actual Null Voltage (mV _{rms})	Actual FM Sensitivity (MHz)	Maximum FM Voltage (mV _{rms})
1	1	1	1	1	0.1	271			
5	1	5	1	1	0.1	271			
9	1	9	1.2	5	0.1	621			
17	1	17	1.3	6	0.1	706			
1	10	1	5	1	1	271			
5	10	5	5	1	1	271			
1	10	1	1	CARRIER	3	510			
5	10	5	1	CARRIER	3	510			

$$\text{Actual FM Sensitivity} = \left(\frac{\text{Calculated Null Voltage}}{\text{Actual Null Voltage}} \right) (\text{Set FM Sensitivity})$$

$$\text{Max FM Deviation} = (\text{Actual FM Sensitivity}) [(1.414) (\text{Max FM Voltage})]$$

Related Adjustments

FM Gain

In Case of Difficulty

If the synthesizer remains *unlocked*, turn AC FM off and begin the procedure from step 13 for the CW frequency in question.

See "TROUBLESHOOTING" in the *Assembly-Level Repair Manual*.

Table 2-25. Test Record for the HP 83623A and 83624A (Page 1 of 7)

Test Facility: _____	
_____	Report Number _____
_____	Date _____
_____	Customer _____
_____	Tested by _____
Model _____	Ambient temperature _____ °C
Serial Number _____	Relative humidity _____ %
Options _____	Line frequency _____ Hz (nominal)
Firmware Revision _____	
Special Notes:	
Substitute ≥ 2.0 GHz for ≥ 2.3 GHz at footnote 1 for HP 83624A only.	

Table 2-25. Test Record for the HP 83623A and 83624A (Page 2 of 7)

Model _____	Report Number _____	Date _____	
Test Equipment Used	Model Number	Trace Number	Cal Due Date
1. Digital Oscilloscope	_____	_____	_____
2. Measuring Receiver	_____	_____	_____
3. Power Sensor	_____	_____	_____
4. Power Meter	_____	_____	_____
5. Microwave Spectrum Analyzer	_____	_____	_____
6. Function Generator	_____	_____	_____
7. _____	_____	_____	_____
8. _____	_____	_____	_____
9. _____	_____	_____	_____
10. _____	_____	_____	_____
11. _____	_____	_____	_____
12. _____	_____	_____	_____
13. _____	_____	_____	_____
14. _____	_____	_____	_____
15. _____	_____	_____	_____
16. _____	_____	_____	_____
17. _____	_____	_____	_____
18. _____	_____	_____	_____
19. _____	_____	_____	_____
20. _____	_____	_____	_____

Table 2-25. Test Record for the HP 83623A and 83624A (Page 3 of 7)

Model		Report Number			Date
Test No.	Test Description	Minimum Spec.	Results	Maximum Spec.	Measurement Uncertainty
1.	Internal Timebase: Aging Rate				
7.	Calculated Rate			5x10 ⁻¹⁰ /day	
2.	Swept Frequency Accuracy				
	Worst Case Value:				
10.	Start Freq _____			0.1% of sweep	
	Stop Freq _____				
3.	Frequency Switching Time				
8.	CW Step:				
	0.01 to 20 GHz			70 ms	
	12.5 to 20 GHz			70 ms	
16.	Stepped Sweep			5 ms	
25.	Frequency List			70 ms	
4.	Power Accuracy				
14.	<2.3 GHz:				
	Power >-10 dBm	-0.6 dB		+0.6 dB	
	Power >+10 dBm	-1.2 dB		+1.2 dB	
	≥2.3 ¹ and ≤20 GHz:				
	Power >-10 dBm	-0.7 dB		+0.7 dB	
	Power >+10 dBm	-1.3 dB		+1.3 dB	
5.	Power Flatness				
5.	<2.3 GHz				
	Power >-10 dBm	-0.5 dB		+0.5 dB	
	Power >+10 dBm	-0.9 dB		+0.9 dB	
6.	≥2.3 ¹ and ≤20 GHz				
	Power >-10 dBm	-0.6 dB		+0.6 dB	
	Power >+10 dBm	-1.0 dB		+1.0 dB	

Table 2-25. Test Record for the HP 83623A and 83624A (Page 4 of 7)

Model		Report Number			Date
Test No.	Test Description	Minimum Spec.	Results	Maximum Spec.	Measurement Uncertainty
6.	Maximum Leveled Power				
	10. Standard (HP 83623A)	+17 dBm	_____		
	Option 001	+15.5 dBm	_____		
	10. Standard (HP 83624A)	+20 dBm	_____		
	Option 001	+18.5 dBm	_____		
7.	External Leveling				
	7. Minimum Power			-0.2 mV	
	9. Maximum Power	-0.5 V	_____		

8.	Spurious Signals:				
	Harmonic				
	7. Harmonics				
	<50 MHz	-20 dBc	_____		
	≥50 MHz and <1.8 GHz	-25 dBc	_____		
	≥1.8 and ≤20 GHz	-25 dBc	_____		
	7. Subharmonics				
	≥7 and ≤20 GHz	-50 dBc	_____		

9.	Spurious Signals:				
	Non-harmonic				
	10. Spur Frequency:				
	_____	-60 dBc	_____		
	_____	-60 dBc	_____		
	_____	-60 dBc	_____		
	_____	-60 dBc	_____		
	125 kHz	-60 dBc	_____		
	500 kHz	-60 dBc	_____		

Table 2-25. Test Record for the HP 83623A and 83624A (Page 5 of 7)

Model		Report Number			Date
Test No.	Test Description	Minimum Spec.	Results	Maximum Spec.	Measurement Uncertainty
9.	Spurious Signals: Non-harmonic (continued)				
	15. Spur Frequency:				
	100 MHz Fixed	-60 dBc	_____		
	100 MHz Offset	-60 dBc	_____		
	LO Feedthrough	-60 dBc	_____		
10.	Spurious Signals: Line Related				
	10. 120 Hz	-55 dBc	_____		
	10. 180 Hz	-55 dBc	_____		
	10. 240 Hz	-55 dBc	_____		
11.	Single Sideband Phase Noise				
	7. Offsets at 6.99 GHz:				
	100 Hz to <1 kHz	-70 dBc	_____		
	1 kHz to <10 kHz	-78 dBc	_____		
	10 kHz to <100 kHz	-86 dBc	_____		
	≥100 kHz	-107 dBc	_____		
	Offsets at 2.23 GHz:				
	100 Hz to <1 kHz	-70 dBc	_____		
	1 kHz to <10 kHz	-78 dBc	_____		
	10 kHz to <100 kHz	-86 dBc	_____		
	≥100 kHz	-107 dBc	_____		
	Offsets at 18.0 GHz:				
	100 Hz to <1 kHz	-60 dBc	_____		
	1 kHz to <10 kHz	-68 dBc	_____		
	10 kHz to <100 kHz	-76 dBc	_____		
	≥100 kHz	-97 dBc	_____		

Table 2-25. Test Record for the HP 83623A and 83624A (Page 6 of 7)

Model		Report Number			Date
Test No.	Test Description	Minimum Spec.	Results	Maximum Spec.	Measurement Uncertainty
12.	Pulse Modulation On/Off Ratio				
	12. On/Off Ratio	80 dB	_____		
13	Pulse Performance				
	11. Rise Time		_____	50 ns	
	11. Fall Time		_____	50 ns	
	23. Level Accuracy p-p		_____	±0.3 dB	
14.	Pulse Modulation Video Feedthrough				
	20. <2.3 GHz at +10 dBm		_____	2%	
	22. <2.3 GHz at >10 dBm		_____	5%	
	27. ≥2.3 ¹ and ≤20.0 GHz		_____	2 mV	
15.	AM Accuracy				
	9. Maximum Difference	95%	_____	105%	
16.	AM Bandwidth				
	10. Maximum Difference p-p		_____	3 dB	
17.	AM Dynamic Range				
	12. Normal		_____	-20 dBm	
	23. Deep		_____	-50 dBm	
18.	FM Accuracy				
	13. Maximum Difference		_____	10%	

Table 2-25. Test Record for the HP 83623A and 83624A (Page 7 of 7)

Model		Report Number			Date
Test No.	Test Description	Minimum Spec.	Results	Maximum Spec.	Measurement Uncertainty
19.	FM Bandwidth				
	17. Maximum Difference p-p		_____	6 dB	
20.	Maximum FM Deviation				
	12. DC FM Unlocked ≤ 100 Hz: > ± 75 MHz Deviation		Pass/Fail		
	22. AC FM Locked 100 kHz: Modulation Index ≥ 5				
	1 GHz	500 kHz	_____		
	5 GHz	500 kHz	_____		
	9 GHz	1 MHz	_____		
	17 GHz	1.5 MHz	_____		
	22. AC FM Locked 1 MHz: Modulation Index ≥ 5				
	1 GHz	5 MHz	_____		
	5 GHz	5 MHz	_____		
	22. AC FM Locked 3 MHz: > ± 8 MHz deviation				
	1 GHz	8 MHz	_____		
	5 GHz	8 MHz	_____		

HP 8360 Series Operation Verification

INTRODUCTION

The following procedures meet the needs of most incoming inspections (80% verification), and provide a reasonable assurance that the instrument is functioning properly. Do the procedures in the order given.

MENUS

If you are not familiar with the menus in this instrument, go to the "MENUS" chapter and fold out the menu maps.

Some menus have more than one page of softkeys. Select the **[More]** softkey to view the next page of softkeys. **[More]** is *not* included in the keystrokes given in these procedures.

THE OPERATION VERIFICATION FORM

Operation verification forms are supplied at the end of this chapter. Use the forms to record the pass/fail results of an operation verification. There may be more than one form provided. Be sure to use the one designated (at the top) for your synthesizer.

1. SELF-TESTS

1. Perform the full self-tests contained in the instrument firmware. No additional test equipment is required. With no connections to the synthesizer, set:

SERVICE **[Selftest (Full)]**

The synthesizer executes a series of self-tests. When completed, the following message is displayed if all the tests passed:

ALL SELF - TESTS HAVE PASSED!

2. Record *Pass* on the operation verification form and continue to the next test, "Power Accuracy".

If the synthesizer fails one or more self-tests, a different message is displayed listing the most independent test that failed and a reference to the best entry point into the "TROUBLESHOOTING" chapter of the *Assembly-Level Repair* manual. Record *Fail* on the operation verification form and see the *Assembly-Level Repair* manual for troubleshooting information. After repair, repeat operation verification from the beginning.

2. POWER ACCURACY

1. Follow the procedure given in "PERFORMANCE TESTS" in this manual.
2. If the synthesizer passes this test, record *Pass* on the operation verification form and continue to the next test, "Maximum Levelled Power".

If the synthesizer fails, record *Fail* on the operation verification form and then follow the "In Case of Difficulty" instructions given for this performance test. After repair, repeat operation verification from the beginning.

3. POWER FLATNESS

1. Follow the procedure given in "PERFORMANCE TESTS" in this manual.
2. If the synthesizer passes this test, record *Pass* on the operation verification form and continue to the next test, "Power Accuracy."

If the synthesizer fails, record *Fail* on the operation verification form and then follow the "In Case of Difficulty" instructions given for this performance test. After repair, repeat operation verification from the beginning.

4. MAXIMUM LEVELED POWER

1. Follow the procedure given in "PERFORMANCE TESTS" in this manual.
2. If the synthesizer passes this test, record *Pass* on the operation verification form. Operation verification is completed.

If the synthesizer fails, record *Fail* on the operation verification form and then follow the "In Case of Difficulty" instructions given for this performance test. After repair, repeat operation verification from the beginning.

Table 2-25. Operation Verification form for the HP 83623A and 83624A

Test Facility _____	Date _____
Model _____	Customer _____
Serial Number _____	Tested By _____
Options _____	Firmware Revision _____
Test	Results (Pass/Fail)
1. Self-Tests	_____
2. Power Accuracy	_____
3. Power Flatness	_____
4. Maximum Leveled Power	_____

3 ADJUSTMENTS

3. HP 8360 Series Adjustments

HOW TO USE THIS CHAPTER

Perform these adjustments only if directed by the "TROUBLESHOOTING" chapter of the *Assembly-Level Repair* manual or if a performance test fails.

Menus

If you are not familiar with the menus in the synthesizer, fold out the menu maps in the "MENUS" chapter (see the following figure).

Some menus have more than one page of softkeys. Select the **[More]** softkey to view the next page of softkeys. **[More]** is *not* included in the keystrokes given in these procedures.

Note



In all cases where you are instructed to preset the synthesizer, use the factory preset mode only.

If a password is set, it will have to be disabled before the adjustment menu can be accessed. See "Calibration Constants" in this manual for instructions.

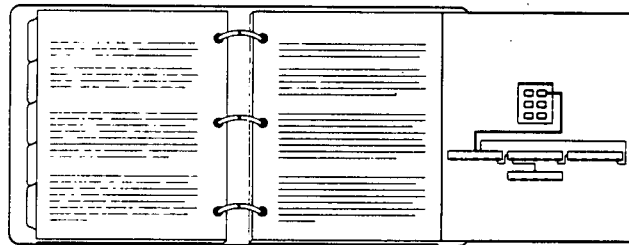

EQUIPMENT REQUIRED

The equipment required to perform the adjustments in this chapter is listed in the "EQUIPMENT REQUIRED" chapter of this manual. You may use any equipment that satisfies the critical specifications given. Use a *non-metallic* adjustment tool.

CAUTIONS AND WARNINGS

Although this instrument has been designed in accordance with international safety standards, for safe operation you must follow the cautions and warnings in this manual.

Warning



Voltages in the instrument can cause personal injury; be extremely careful. Capacitors can be charged even if the instrument has been disconnected from line power.

Table 3-1. Adjustments

Adjustment	Page
1. 10 MHz Standard	3-3
2. Fractional-N VCO	3-7
3. Fractional-N Reference and API Spurs	3-9
4. Sweep Ramp	3-13
5. Sampler Assembly	3-15
6. YO Driver +10V Reference	3-21
7. YO Driver Gain and Linearity	3-23
8. YO Loop Gain	3-25
9. Amplifier Detector Offset	3-27
10. SYTM Adjustments	3-29
11. Low Power SRD Bias	3-53
12. Amplifier Detector Gain	3-57
13. Modulator Offset and Gain	3-59
14. ALC Power Level Accuracy	3-63
15. Power Flatness	3-69
16. AM Accuracy	3-71
17. AM Delay	3-75
18. Pulse Delay	3-77
19. FM Gain	3-81
20. Square Wave Symmetry	3-85

For the following adjustments, see "AUTOMATED TESTS":

- YO Delay Adjustment.
- Step Attenuator Flatness Adjustment.
- ADC Adjustment.
- Power Flatness.

1. 10 MHZ STANDARD

Description and Procedure

This procedure adjusts the frequency accuracy of the internal 10 MHz time base. This adjustment should be done on a regular basis if absolute frequency accuracy is important (see figure 3-3.)

For best accuracy, readjust the 10 MHz timebase oscillator after the synthesizer has been on or in standby for 24 hours. See "Accuracy Versus Adjustment Interval," following this adjustment, for information on how to determine a periodic adjustment schedule.

After the timebase is adjusted, the timebase frequency should stay within the aging rate if the following things happen:

- The time base oven does not cool down.
- The instrument keeps the same orientation with respect to the earth's magnetic field.
- The instrument stays at the same altitude.
- The instrument does not receive any mechanical shock.

If the time base oven cools (the instrument is disconnected from ac power), you may have to readjust the time base frequency after a new warmup cycle. Typically, however, the time base frequency returns to within ± 1 Hz of the original frequency.

Note



You can adjust the internal timebase after reconnecting ac power for 10 minutes, but for best accuracy, test again after the instrument has been on or in standby for 24 hours.

Frequency changes, due either to a change in orientation with respect to the earth's magnetic field or to a change in altitude, are usually eliminated when the instrument is returned to its original position. A frequency change due to mechanical shock usually appears as a fixed frequency error.

1. Connect the equipment as shown in figure 3-1. Preset all instruments and let them warm up for one hour.

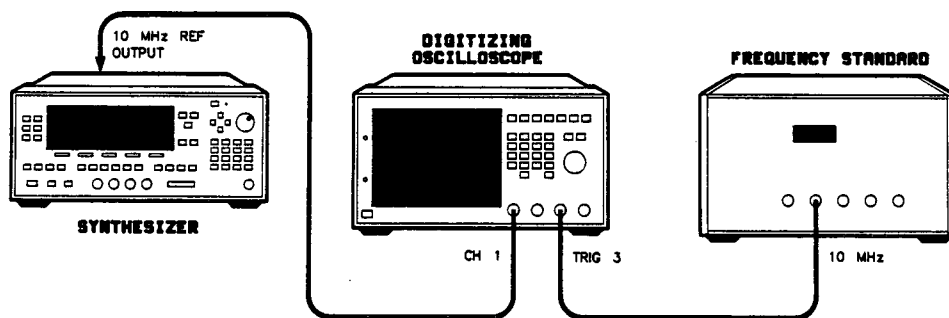

Note



If the oscilloscope does not have a 50 Ω input impedance, connect channel 1 through a 50 Ω feedthrough.

Figure 3-1. 10 MHz Standard Adjustment Setup

- On the oscilloscope, set:

Channel 1:

Display	On
Volts/Division	200 mV
Input Coupling	dc
Input Impedance	50 Ω

Channel 2:

Display	Off
---------	-----

Timebase:

Time/Division	10 ns
Trigger	External

Trigger:

Trigger Mode	Edge
Trigger Source	Trig 3
Input Coupling	ac

Display:

Display Mode	Real Time
--------------	-----------

- On the oscilloscope, adjust the trigger level so that the sweep is synchronized to the synthesizer's internal standard. The waveform will appear to drift.
- Using a non-metallic tool, adjust the A23 10 MHz standard (see figure 3-2) for minimum horizontal movement of the oscilloscope waveform.

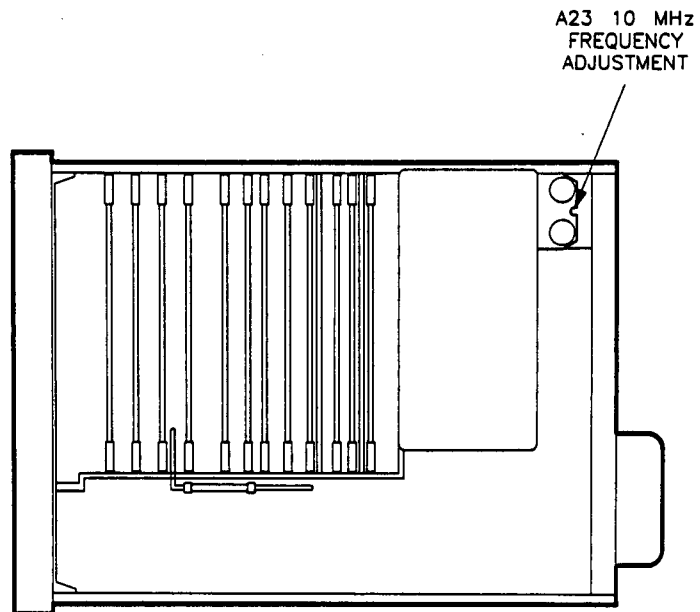

Figure 3-2. 10 MHz Standard Adjustment Location

Related Performance Tests

Internal Timebase: Aging Rate

In Case of Difficulty

1. Ensure that an external standard is not connected. (At instrument preset the synthesizer automatically chooses the external standard as the reference if one is connected to the 10 MHz REF INPUT.)
2. See "TROUBLESHOOTING" in the *Assembly-Level Repair* manual.

ACCURACY VERSUS ADJUSTMENT INTERVAL

Figure 3-3 shows the required adjustment interval to maintain a given accuracy. If you know the aging rate, you can determine a more precise adjustment interval.

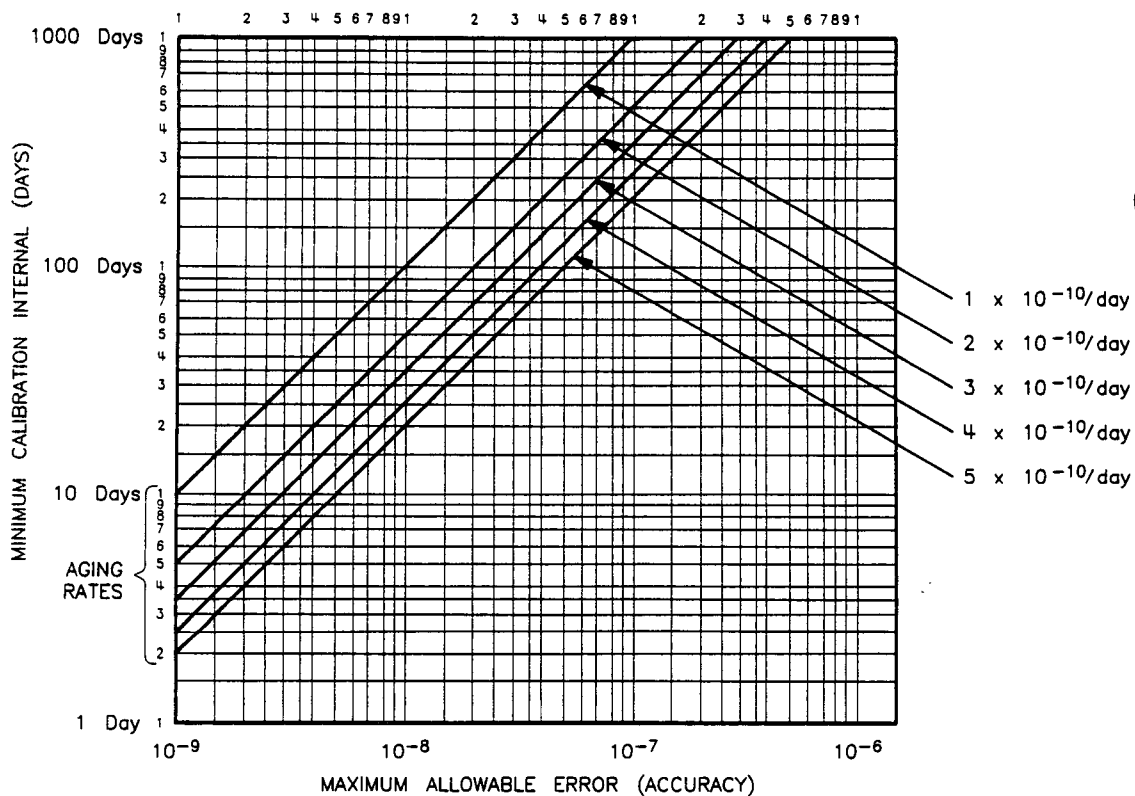

Figure 3-3. Accuracy Versus Adjustment Interval

1. Find the line on figure 3-3 that corresponds to the 10 MHz timebase oscillator aging rate (to determine the aging rate, see "Performance Tests").
2. On the horizontal axis, find the maximum allowable error (accuracy) that you want.
3. Follow the maximum allowable error vertically until it intersects the known aging rate.
4. From the point of intersection, move horizontally to the left and read the minimum calibration interval measured in days.

An Alternate Method

You can also determine the minimum calibration interval using the following formula:

$$\frac{\text{maximum allowable error}}{\text{known aging rate (per day)}} = \text{calibration interval in days}$$

2. FRACTIONAL-N VCO

Description and Procedure

No test equipment is required for this procedure.

This adjustment sets the VCO tuning voltage to $-6.0V$ for a VCO output of 60 MHz.

1. Leaving all cables connected, place the A4 fractional-N assembly on an analog extender board.
2. Turn the synthesizer on and press **PRESET**. Let the instrument warm up for at least one hour.
3. Select the A4 VCO tune adjustment. On the synthesizer, set:
SERVICE **[Adjust Menu]** **[AssyAdj Menu]** **[A4 VCO Tune]**
4. Using a non-metallic tool, adjust A4L1 (see figure 3-4) to center the needle on the display.

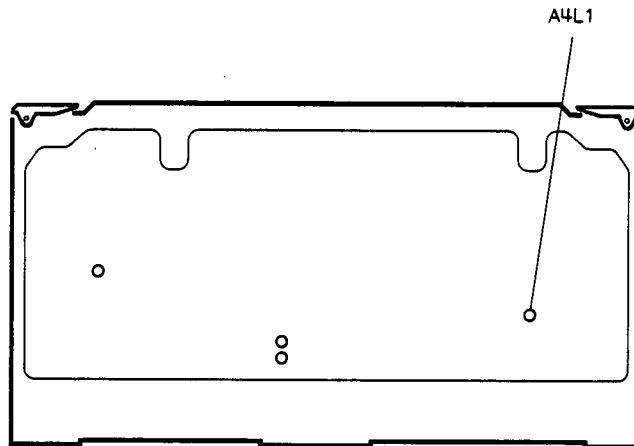

Figure 3-4. A4L1 Location

5. Turn the synthesizer to standby, and reinstall the A4 assembly.

Related Performance Tests

Self-tests

Frequency Switching Time

Single Sideband Phase Noise

In Case of Difficulty

1. Verify that an analog extender board is used.
2. Make sure the 125 kHz reference cable, W11, is connected to A4J1.
3. For synthesizers with option 003, use the "Front Panel Emulation Software" described in the "AUTOMATED TESTS" chapter of this manual or use a substitute front panel.
4. See "TROUBLESHOOTING" in the *Assembly-Level Repair* manual.

3. FRACTIONAL-N REFERENCE AND API SPURS

Note



Do *not* perform this adjustment on a new or rebuilt replacement assembly. The A4 assembly is factory-adjusted, and is *not* instrument dependent.

Description and Procedure

This adjustment minimizes three known spurs (125 kHz reference, API 1, and API 2). At each spur frequency, the spectrum analyzer is phase locked to the synthesizer, connected directly to the A4 fractional-N assembly output, and operated in zero span. A4R70, R31, and R30 are adjusted for minimum spur level. Table 3-2 summarizes this adjustment.

Table 3-2. Summary of Fractional-N Reference & API Spurs Adjustment

Spur	Fractional-N CW Frequency (MHz)	Analyzer Frequency (MHz)	Potentiometer	Minimum dBc
125 kHz Reference	44.125	44.0	A4R70	-75
API 1	44.005	44.0	A4R31	-70
API 2	44.0005	44.0055	A4R30	-80

1. With the A4 assembly on an analog extender board, connect the equipment as shown in figure 3-5. Preset the instruments, and let them warm up for at least one hour.

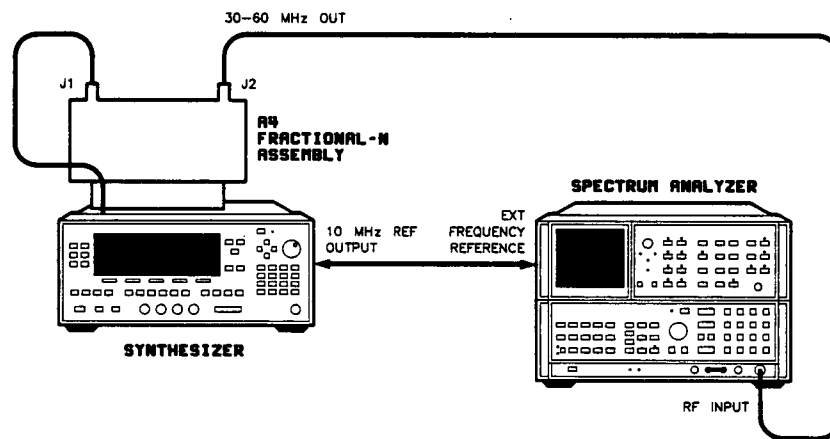

Figure 3-5. Fractional-N Reference and API Spur Adjustment Setup

2. On the spectrum analyzer, set:

Frequency Span: 0 Hz
Resolution Bandwidth: 10 Hz
Sweep Time: 10 s
Reference Level: -10 dBm
Scale Log: 10 dB/Division
Video Averaging: Off
Clear Write A: Selected

125 kHz Reference Spur Adjustment

3. On the synthesizer, set:

CW

SERVICE **[Tools Menu]** **[Cnt/PLL Menu]** **[Frac N Menu]** **[CW]** **44.125** **MHz**

4. On the spectrum analyzer, set:

Center Frequency: 44.125 MHz

Frequency Span: 500 Hz

Adjust the frequency offset to center the signal on the display.

Frequency Span: 0 Hz

Peak the signal on the display.

Note the signal level: _____ dBm

Center Frequency: 44.0 MHz

Reference Level: -40 dBm

- On the synthesizer, adjust A4R70 (see figure 3-6) for minimum signal on the spectrum analyzer.

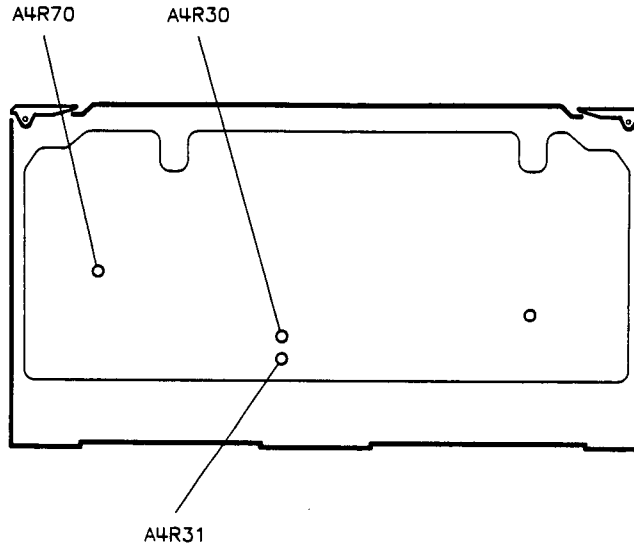

Figure 3-6. Fractional-N Reference and API Spurs Adjustment Locations

The difference in level between the signal noted in step 4 and the signal in this step should be at least -75 dBc.

API 1 Spur Adjustment

- On the synthesizer, change the fractional-N to CW 44.005 MHz. Press:

44.005 **MHz**

- On the spectrum analyzer, set:

Center Frequency: 44.005 MHz

Reference Level: +10 dBm

Note the signal level: _____ dBm

Center Frequency: 44.0 MHz

Reference Level: -40 dBm

- On the synthesizer, adjust A4R31 (see figure 3-6) for minimum signal on the spectrum analyzer.

The difference in level between the signal noted in step 7 and the signal in this step should be at least -70 dBc.

API 2 Spur Adjustment

9. On the synthesizer, change the fractional-N to CW 44.0005 MHz. Press:

44.0005 **MHz**

10. On the spectrum analyzer, set:

Center Frequency: 44.0005 MHz

Reference Level: +10 dBm

Note the signal level: _____ dBm

Center Frequency: 44.0055 MHz

Reference Level: -40 dBm

11. On the synthesizer, adjust A4R30 (see figure 3-6) for minimum signal on the spectrum analyzer.

The difference in level between the signal noted in step 10 and the signal in this step should be at least -80 dBc.

12. Turn the synthesizer to standby and reinstall the A4 assembly.

Performance Tests

Spurious Signals (Non-Harmonics)

In Case of Difficulty

1. Ensure that the spectrum analyzer is locked to the external reference.
2. You may need to use video averaging on the spectrum analyzer if the spur level is low enough to be hidden by phase noise.
3. If you cannot adjust spurs below the recommended levels, the problem is probably with the A4 fractional-N assembly. See "TROUBLESHOOTING," in the *Assembly-Level Repair* manual.

4. SWEEP RAMP

Description and Procedure

No test equipment is required for this adjustment.

This is an automatic adjustment. The synthesizer's internal DVM measures the sweep ramp voltage at the end of the sweep. The synthesizer then sets the sweep time calibration constants to calibrate the sweep ramp.

1. Turn the synthesizer on and press **PRESET**. Let the synthesizer warm up for at least one hour.
2. Select the A14 sweep ramp adjustment. On the synthesizer, set:

SERVICE [Adjust Menu] [AssyAdj Menu] [A14 SwpRmp]

The synthesizer will measure, calculate, and store the sweep time calibration constants. When the adjustment is complete, the following message appears on the display:

Sweep Ramp Cal Completed

Calibration constants were modified.

3. If this is the last calibration constant you will be adjusting, see "Calibration Constants" to store the calibration constants as protected data (in EEPROM).

Related Performance Tests

Self-Tests
Swept Frequency Accuracy

In Case of Difficulty

See "TROUBLESHOOTING" in the *Assembly-Level Repair* manual.

5. SAMPLER ASSEMBLY

Description and Procedure

No test equipment is required for this procedure.

There are four sampler assembly adjustments:

- In the 200 MHz loop VCO tune adjustment, the synthesizer uses an internal DVM to let you adjust the VCO in the 200 MHz loop.
 - In the sampler match adjustment, as the internal DVM monitors the loop input to the sampler, you adjust trim capacitors to optimize the sampler match over the full frequency range of the loop.
 - The 200 MHz loop gain adjustment is automatic. When you select this adjustment in the A6 adjustment menu, the synthesizer selects internal calibration constants for optimum loop gain over the full frequency range of the loop.
 - In the IF gain adjustment, as the internal DVM monitors the IF output level to the YO loop, you adjust the IF amplifier gain.
1. Turn the synthesizer to standby. At FL2 (see figure 3-7), disconnect the semi-rigid cable between FL2 and the A6 assembly.

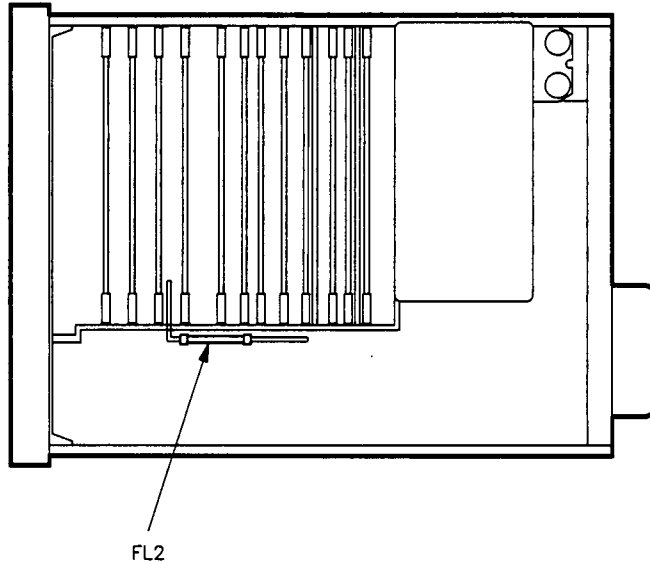

Figure 3-7. FL2 Location

2. Leaving the flexible cable connected to A6J1 (40 MHz reference), place the A6 assembly on the analog extender board.
3. Turn the synthesizer on and press **PRESET**. Let it warm up for at least one hour.
4. Select the A6 adjustment menu. Press:
SERVICE [**Adjust Menu**] [**AssyAdj Menu**] [**A6 Adj Menu**]

200 MHz Loop VCO Tune Adjustment

5. In the A6 adjustment menu, select the A6 VCO tune adjustment, [**A6 VCO Tune**].
6. Adjust A6C55 (see figure 3-8) to center the "needle" on the display.

If the needle does not adjust (remains fully to the left or right), add or subtract fixed trim capacitors. See the "VCO Fixed Trim Capacitor Selection" procedure at the end of this adjustment procedure.

7. Select [**Done**].

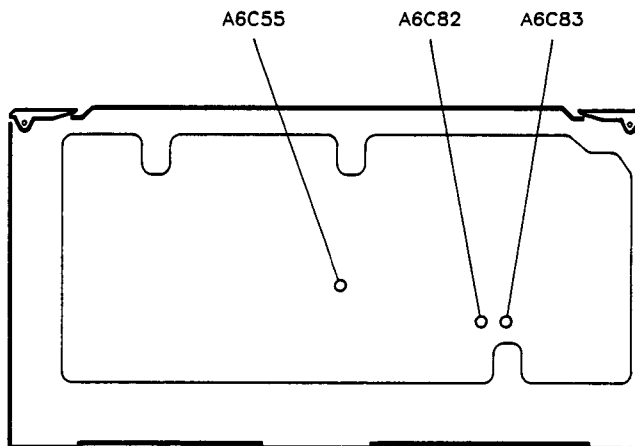

Figure 3-8. 200 MHz Loop VCO Tune and Sampler Match Adjustment Locations

Sampler Match Adjustment

8. In the A6 adjustment menu, select the A6 sampler match adjustment, **[A6 Smplr Match]**.

Note



The sampler match display is a graphic representation of the sampler match over the full frequency range of the 200 MHz loop. The more asterisks displayed at a frequency, the more output signal (and the better the match) at that frequency. Make the adjustment for best match over the full frequency range of the loop.

9. Adjust A6C82 and A6C83 (figure 3-8) for best overall sampler match.
10. Select **[Done]**.

200 MHz Loop Gain Adjustment

11. In the A6 adjustment menu, select the A6 loop gain adjustment, **[A6 Loop Gain]**. The synthesizer automatically performs the adjustment. When the message **Calibration Constants should be SAVED** is displayed, the adjustment is complete. Continue with the next step.
12. Set the synthesizer to standby. Reinstall the A6 assembly in the instrument, and connect all cables.

IF Gain Adjustment

13. Turn the synthesizer on. Select **[A6 IF Gain]**.
14. Adjust A6R73 (see figure 3-9) to center the "needle" on the display.

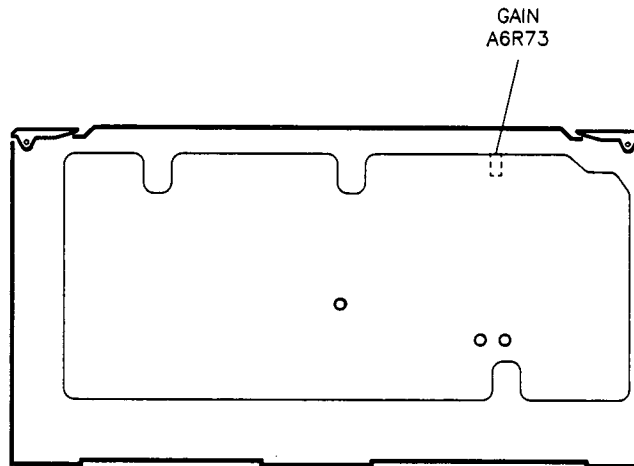

Figure 3-9. IF Gain Adjustment Location

15. Select **[Done]**.
16. If this is the last calibration constant you will be adjusting, see "Calibration Constants" to store the calibration constants as protected data (in EEPROM).

Related Performance Tests

Self-tests
Frequency Switching Time
Spurious Signals (Non-Harmonics)
Single Sideband Phase Noise

In Case of Difficulty

1. Make sure the 40 MHz reference input cable is connected while the A6 assembly is on the analog extender board.
2. For the IF gain adjustment, if the needle registers on the far left or right, ensure that all coax cables (including semi-rigid) are connected and that no unlocked message is displayed.
3. There is some interaction between the adjustments in this procedure. Try an alternate order of adjustments.
4. See "TROUBLESHOOTING" in the *Assembly-Level Repair* manual.

VCO FIXED TRIM CAPACITOR SELECTION

Note



The shields on the A6 assembly affect the capacitance value. You must have the shield on to make the adjustment. Take the shield off to remove or add capacitors. Put the shield back on to determine the effect of adding or deleting capacitors.

1. If the needle is to the right of center with the A6C55 capacitor fully counterclockwise, remove capacitors, one at a time, until the needle is to the left of center. See figure 3-10 for capacitor locations.

Repeat the 200 MHz Loop VCO Tune adjustment.

2. If the needle is to the left of center with the A6C55 capacitor fully clockwise, add capacitors (HP part number 0160-5896), one at a time, until the needle is to the right of center. See figure 3-10 for capacitor locations.

Repeat the 200 MHz Loop VCO Tune adjustment.

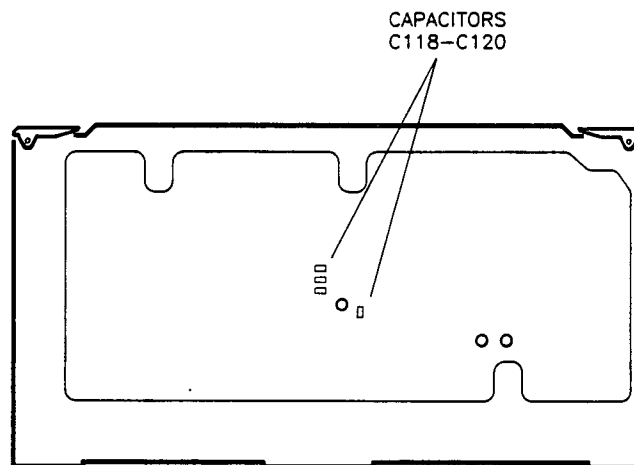

Figure 3-10. Capacitor Locations

6. YO DRIVER +10V REFERENCE

Description and Procedure

No test equipment is required for this procedure.

As the internal DVM monitors the +10V reference, you make the adjustment.

1. Turn the synthesizer on and press **PRESET**. Let the instrument warm up for at least one hour.
2. Select the A13 adjustment menu. On the synthesizer, set:
SERVICE **[Adjust Menu]** **[AssyAdj Menu]** **[A13 Adj Menu]**
3. Select the A13 +10V reference adjustment, **[A13 +10V Ref]**.
4. Adjust A13R11 (see figure 3-11) to center the "needle" on the display.

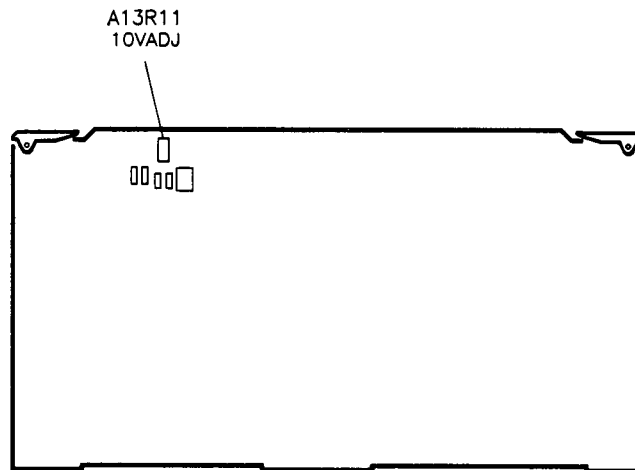

Figure 3-11. YO Driver +10V Reference Adjustment Location

5. Select **[Done]**.

Related Performance Tests

Self-tests

In Case of Difficulty

See "TROUBLESHOOTING" in the *Assembly-Level Repair* manual.

7. YO DRIVER GAIN AND LINEARITY

Description and Procedure

No test equipment is required for these adjustments.

For the gain adjustment, the synthesizer's internal DVM monitors the YO loop error voltage at two frequencies (points B and C in 3-12). When you select the gain potentiometer adjustment, the synthesizer displays the difference in voltage between points B and C as a "needle" with arrows on either side. By adjusting A13R54 to center the "needle," you equalize the voltage between the two frequency points.

The linearity adjustment has two parts (each of which is selected and adjusted similarly to the gain adjustment). The low breakpoint adjustment equalizes the voltage between points A and B in figure 3-12. The high breakpoint adjustment equalizes the voltage between points C and D.

Note



You must adjust the gain first, then adjust the breakpoints.

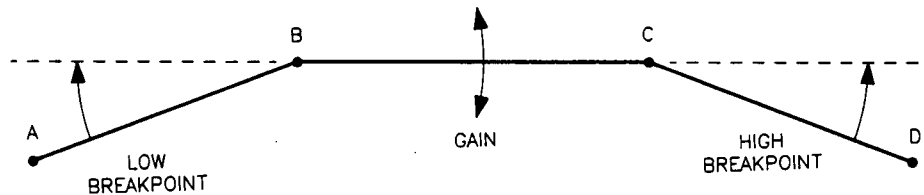

Figure 3-12. YO Gain and Linearity Breakpoints

1. Turn the synthesizer on and press **PRESET**. Let it warm up for at least one hour.
2. Select the A13 gain menu. Press:

SERVICE [*Adjust Menu*] [*AssyAdj Menu*] [*A13 Adj Menu*] [*A13 Gain Menu*]

Note



If the following message is displayed: Adjust A13 pot until "locked", adjust the potentiometer until the locked indication is displayed. Continue with step 3.

3. Select the gain potentiometer adjustment, **[Gain Pot]**.
4. Adjust A13R54 (see figure 3-13) to center the "needle" on the display.

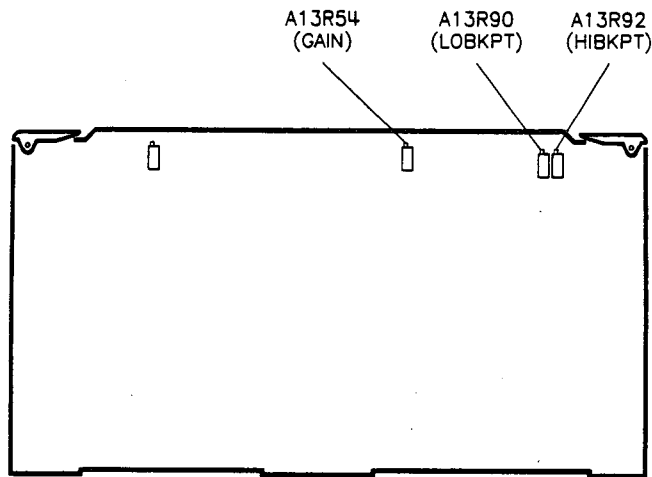

Figure 3-13. YO Gain and Linearity Adjustment Locations

5. Select the low breakpoint potentiometer adjustment, **[Lo Bk Pot]**.
6. Adjust A13R90 (see figure 3-13) to center the "needle" on the display.
7. Select the high breakpoint potentiometer adjustment, **[Hi Bk Pot]**.
9. Adjust A13R92 (see figure 3-13) to center the "needle" on the display.
10. Select **[Done]**.
11. If this is the last calibration constant you will be adjusting, see "Calibration Constants" to store the calibration constants as protected data (in EEPROM).

Related Performance Tests

Self-tests

In Case of Difficulty

See "TROUBLESHOOTING" in the *Assembly-Level Repair* manual.

8. YO LOOP GAIN

Description and Procedure

No test equipment is required for this procedure.

1. Turn the synthesizer on and press **PRESET**. Let the instrument warm up for at least one hour.
2. Select the assembly adjustment menu. Press:
SERVICE [*Adjust Menu*] [*AssyAdj Menu*]
3. Select the A5 loop gain adjustment, [*A5 Loop Gain*].
4. On the A5 assembly, set all five switches on A5S1 to the closed position (see figure 3-14).

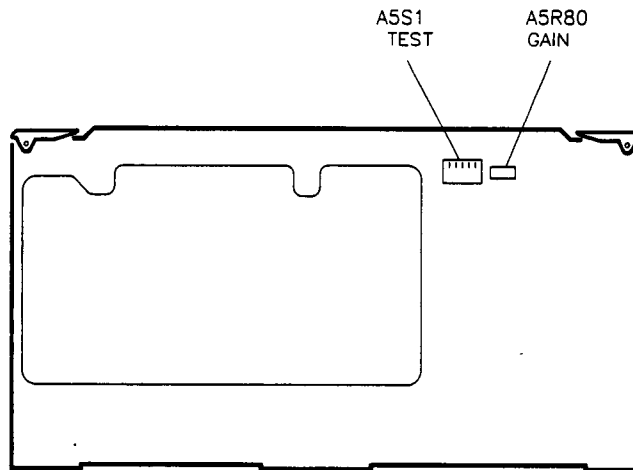

Figure 3-14. Switch and Adjustment Locations

5. Adjust A53R80 (see figure 3-14) to center the "needle" on the display.
6. Select [*Done*].
7. Set all A5 switches to open and select [*Done*].

Performance Tests

Single Sideband Phase Noise

In Case of Difficulty

1. Be sure to close the A5S1 switches before making the adjustment and open the switches when the adjustment is complete.
2. See "TROUBLESHOOTING" in the *Assembly-Level Repair* manual.

9. AMPLIFIER DETECTOR OFFSET

Description and Procedure

No additional test equipment is required for this procedure.

The analog bus monitors the detector track/hold signal on the A9 pulse driver assembly with the RF power turned off. This adjustment minimizes the dc voltage at the monitoring point.

1. Turn the synthesizer on and press **PRESET**. Let the instrument warm up for at least one hour.
2. Select the A9 detector offset adjustment. Press:
SERVICE *[Adjust Menu]* *[AssyAdj Menu]* *[A9 DetOfs]*
3. Adjust A9R87 (see figure 3-15) to center the "needle" on the display.

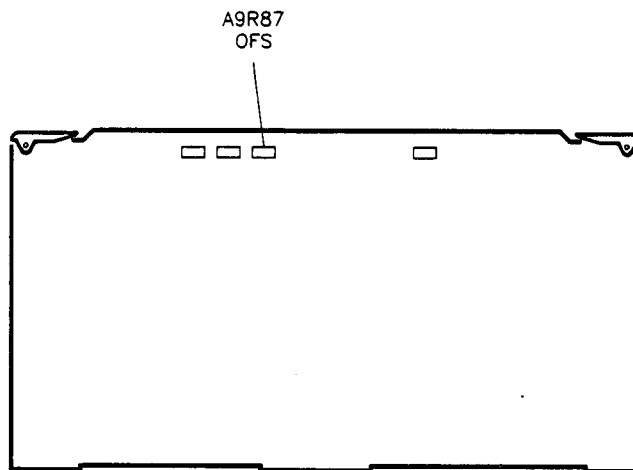

Figure 3-15. Amplifier Detector Offset Adjustment Location

4. Select *[Done]*.

Related Performance Tests

Maximum Leveled Power

In Case of Difficulty

See "TROUBLESHOOTING" in the *Assembly-Level Repair* manual.

10. SYTM ADJUSTMENTS

Description and Procedure

This procedure maximizes RF power by tracking the tuned filter in the SYTM to the RF output frequency. Initial tracking is done in single band sweeps at slow sweep speeds to eliminate the effects of bandcross and hysteresis in the tuning coil. (Those will be corrected with delay and risetime calibration constants.) A squegging clamp adjustment limits the power into the SYTM and is adjusted for maximum output power without squegging. The SRD bias adjustments are made to optimize the efficiency of the frequency multiplication. Auto tracking is initiated to optimize the slow sweep tracking.

The YTM delay compensation adjustments maximize power for fast single- and multi-band sweeps. The YTM risetime adjustments are done in multi-band fast sweeps to optimize power at the start of each frequency band.

Note



If you have replaced either the YO, the YO driver, or the SYTM driver, first initiate an auto tracking procedure. Terminate the RF OUTPUT with a good 50Ω impedance match such as a 10 dB attenuator or a power sensor (not necessary for synthesizers with a step attenuator). Press **USER CAL** [*Tracking Menu*] [*Auto Track*]. If auto tracking passes and the instrument passes the "Maximum Leveled Power" performance test, do not continue with this procedure. If auto tracking fails, (an error message is displayed), continue with this procedure.

Adjustment Help

The following explanations are provided for a better understanding of the SYTM adjustments. Refer to these explanations as often as necessary. They will help make these adjustments easier. (The adjustment procedure begins on page 35.)

Changing Calibration Constant Values

- When setting most calibration constants, use the left and right arrow keys. They decrement and increment the values in steps of 1. This helps you to keep track of the adjustment range while monitoring the trace on the display.

For offset and gain adjustments, the adjustment range is often so large it is easier to use the rotary knob to set the calibration constants.

Setting the Fastest Sweep Time

- Setting the sweep time to 0 milliseconds sets the synthesizer to the fastest sweep time for the frequency range being swept. Each time the frequency range is changed, the sweep time must be reset to 0 msec in order to maintain the fastest sweep time.

Offset and Gain Adjustments

- For all offset and gain adjustments, adjust *through* the bandpass: Keep adjusting until the power peaks and then drops off. Then reset the adjustment to the peaked point.
- For all offset and gain adjustments, if power stays peaked over several calibration constant values, set the calibration constant to the middle value of the peaked range.

Squegg Clamp Calibration Constants

The squegg clamp calibration constants are adjusted to decrease the clamp on the SYTM as far as possible to achieve the greatest power without squegging.

- When increasing any squegg clamp calibration constant, power is increased too far when any of the following occurs:
 - Any portion of the trace is distorted or power drops out in a portion of the trace (sphere squegging).
 - Power drops over a broad frequency range (diode squegging).
 - Power stops increasing on any portion of the trace.
- Diode squegging is the primary form of squegging in band 2.
- Sphere squegging is the only form of squegging in band 1.
- After increasing power to the peak, decrease power by 1.5 to 2 dB across the entire band. Power should decrease uniformly across the entire band.

Adjusting for a Dip

- When adjusting for a dip at the high end of the band, adjust until the power peaks, then dips (reaches minimum power). Dips may be smaller than 1/3 division ($\cong 0.5$ dB.) Note the calibration constant where this occurs. Continue adjusting in the same direction until the power peaks again. Return the adjustment to the power level of the dip.
- The passband of the SYTM varies with frequency. The SYTM adjustments set the input frequency to the SYTM to the center of the passband. Adjusting for the dip at higher frequencies actually adjusts for the dip which occurs in the center of the passbands of those frequencies (see figure 3-16).

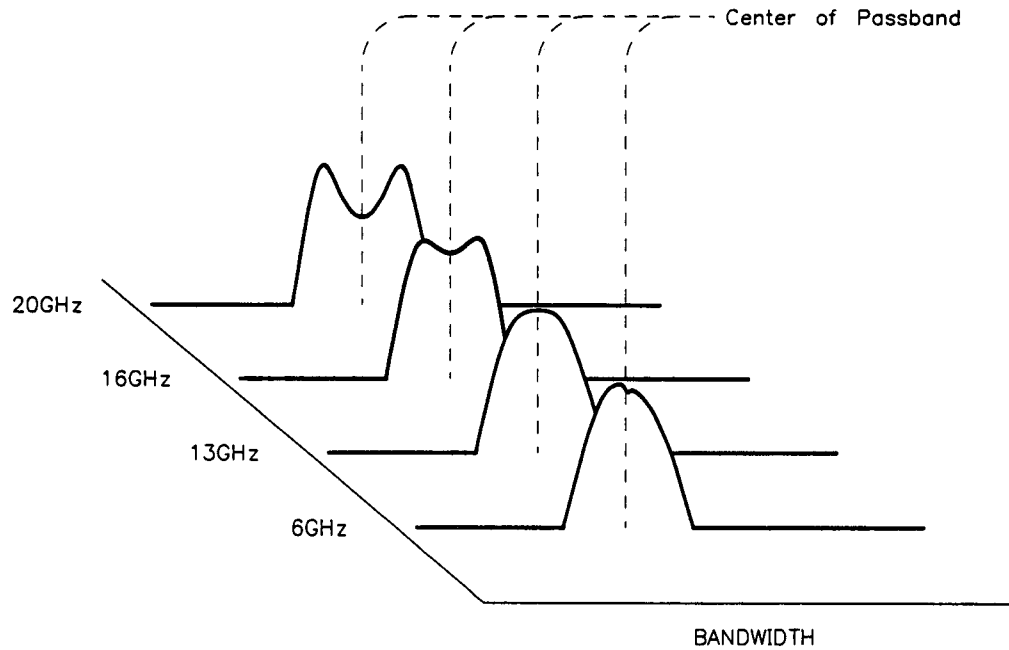

Figure 3-16. SYTM Passband Versus Frequency

SRD Bias Adjustment

- When adjusting the SRD bias, decrease power by 1.3 division ($\cong 0.5$ dB) after reaching peak power.

Single Band Delay Compensation Adjustments

- If a drop in power greater than 1 division occurs when in single sweep, increase the A delay term to put the A term at the high end of the peak. For example, for the following calibration constant values:

Start of the peak = 1800
Middle of the peak = 1950
End of the peak = 2100

Set the A term to 2050

See figure 3-17a for a graphic representation of the frequencies affected by the calibration constants.

Sweep Speed Related Adjustments

- Delay compensation and risetime adjustments are affected by sweep speed. The adjustments are performed at fast sweep speeds which are the worst case. All other adjustments are performed at slow sweep speeds; they are not affected by sweep speed.

If you have a sweep speed problem, it is probably affected by delay compensation or risetime adjustments.

YTM Bandcross Delay Terms

The YTM Bx Dly terms are either offset or gain terms. A1 denotes the offset term for band 1. B1 denotes the gain term for band 1. The offset (A) should be adjusted to maximize power at the beginning of the band. The gain (B) is adjusted to maximize power toward the end of the band.

See figure 3-17 for a graphic representation of the frequencies affected by the calibration constants.

YTM RiseTime Compensation

YTM Risetime compensation minimizes power dropouts that occur at the start of a band. These calibration constants will only help if the dropout does not occur during slow sweep speeds (> 500 msec). When adjusting, set the risetime calibration constant to 1, then increment until the power dropout is removed (the smaller the number, the better).

Band 2 has three risetime calibration constants:

YTM Rise; Band 2 A1
YTM Rise; Band 2 B1
YTM Rise; Band 2 A2

Band 3 has five risetime calibration constants:

YTM Rise; Band 3 A1

YTM Rise; Band 3 B1

YTM Rise; Band 3 A2

YTM Rise; Band 3 B2

YTM Rise; Band 3 A3

A1 indicates that the start of sweep is in the lower half of band 1. *B1* indicates that the start of sweep is in the upper half of band 1. *A2* indicates that the start of sweep is in the lower half of band 2. *B2* indicates that the start of sweep is in the upper half of band 2.

If the YTM Rise calibration constant has no effect, set it to 1.

See figure 3-17b for a graphic representation of the frequencies affected by the calibration constants.

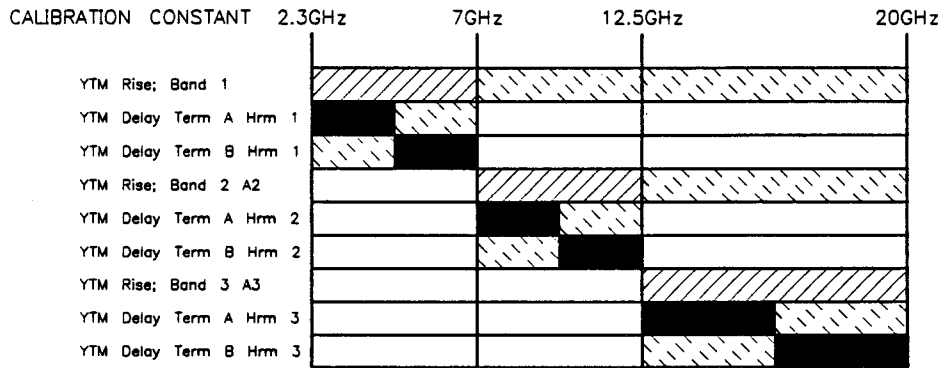
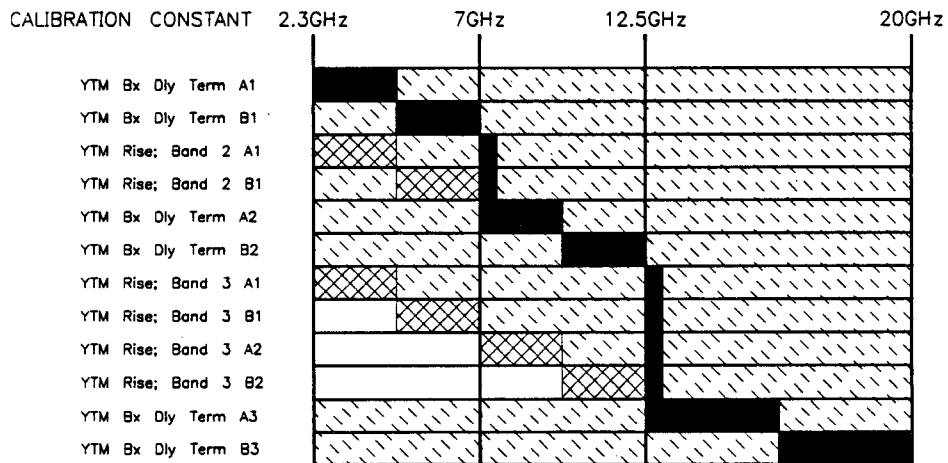

Figure 3-17a. Single-Band Delay and Risetime Compensation



- Frequencies affected by calibration constant.
- Start of sweep frequencies that enable calibration constants.
- Risetime affects start of sweep when sweep starts in this frequency range.
- Range of possible sweep.

EXAMPLE: YTM Rise; Band 3 B1 affects the beginning of Band 3 when the sweep starts in the second half of Band 1 and ends in Band 3.

Figure 3-17b. Multi-Band Delay and Risetime Compensation

Procedure

1. Connect the equipment as shown in figure 3-18 with the RF deck installed on an extender board. Use the extender board and extender cable provided in the service kit and see "DISASSEMBLY AND REPLACEMENT PROCEDURES" in the *Assembly-Level Repair* manual for instructions. Disconnect the semi-rigid cable W56 between the A28 SYTM and the A33 Amplifier/Switch (you will need to loosen A33 in order to remove W56). Do not connect the power meter yet. Power on all the instruments and let them warm up for at least one hour.
2. On the synthesizer, set:
PRESET **USER CAL** [*Tracking Menu*] [*Peak RF Always*] (asterisk on)
3. On the power meter:
Zero and calibrate the power meter/sensor.
Set the power meter to dBm mode.

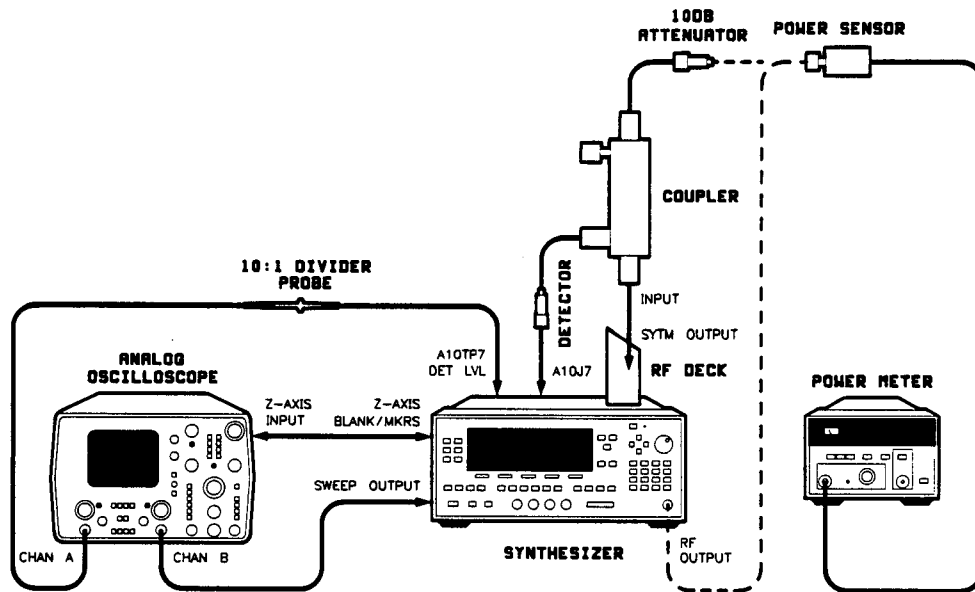

Figure 3-18. SYTM Adjustments Setup

4. Set the default values given in table 3-3 into the corresponding YTM calibration constants. On the synthesizer, set:

SERVICE [Adjust Menu] [Calib Menu]

Select Cal Enter the number of the first calibration constant from table 3-3 and terminate the entry with **ENTER**.

[Modify Cal] Enter the default value from table 3-3 and terminate the entry with **ENTER**.

Using the up/down arrow keys, select each of the rest of the calibration constants in table 3-3 and set their default values by entering the value on the numeric keypad. Terminate your entry with the **ENTER** key.

Table 3-3. YTM Calibration Constants and Default Values (1 of 3)

Number	Description	Default Value	Adjustment Description
105 106 107 108 109 110 111	SRD Bias A; Band 1 SRD Bias A; Band 2 SRD Bias A; Band 3 SRD Bias A; Band 4 SRD Bias A; Band 5 SRD Bias A; Band 6 SRD Bias A; Band 7	50 80 80 80 80 80 80	Maximize power over lower 30% of band. Sweep speed is not a factor. Adjust for 0.5 dB below maximum power.
118 119 120 121 122 123 124	SRD Bias B; Band 1 SRD Bias B; Band 2 SRD Bias B; Band 3 SRD Bias B; Band 4 SRD Bias B; Band 5 SRD Bias B; Band 6 SRD Bias B; Band 7	50 80 80 80 80 80 80	Maximize power over higher 30% of band. Sweep speed is not a factor. Adjust for 0.5 dB below maximum power.
131 132 133 134 135 136 137	Squegg Clamp Band 1 Squegg Clamp Band 2 Squegg Clamp Band 3 Squegg Clamp Band 4 Squegg Clamp Band 5 Squegg Clamp Band 6 Squegg Clamp Band 7	70 120 120 120 120 120 120	Maximize power across the band without squegging. Adjusted at slow sweep speeds and single sweep mode where the SYTM sphere is most likely to squegg.
144 145 146 147 148 149 150	YTM Delay Term A Hrm 1 YTM Delay Term A Hrm 2 YTM Delay Term A Hrm 3 YTM Delay Term A Hrm 4 YTM Delay Term A Hrm 5 YTM Delay Term A Hrm 6 YTM Delay Term A Hrm 7	1600 1600 1600 1600 1600 1600 1600	Maximize power over first 20% of band. Affects fast sweeps only. Single sweep mode is also critical.

Table 3-3. YTM Calibration Constants and Default Values (2 of 3)

Number	Description	Default Value	Adjustment Description
157	YTM Delay Term B Hrm 1	300	Maximize power over higher 30% of band. Affects fast sweeps only.
158	YTM Delay Term B Hrm 2	300	
159	YTM Delay Term B Hrm 3	300	
160	YTM Delay Term B Hrm 4	300	
161	YTM Delay Term B Hrm 5	300	
162	YTM Delay Term B Hrm 6	300	
163	YTM Delay Term B Hrm 7	300	
170	YTM Bx Dly Term A1	1600	Delay compensation for multi-band sweeps only. Adjust for maximum power at lower 50% of band. Affects fast sweep speeds only.
171	YTM Bx Dly Term A2	1600	
172	YTM Bx Dly Term A3	1600	
173	YTM Bx Dly Term A4	1600	
174	YTM Bx Dly Term A5	1600	
175	YTM Bx Dly Term A6	1600	
176	YTM Bx Dly Term A7	1600	
183	YTM Bx Dly Term B1	300	Delay compensation for multi-band sweeps only. Adjust for maximum power at higher 30% of band. Affects fast sweep speeds only.
184	YTM Bx Dly Term B2	300	
185	YTM Bx Dly Term B3	300	
186	YTM Bx Dly Term B4	300	
187	YTM Bx Dly Term B5	300	
188	YTM Bx Dly Term B6	300	
189	YTM Bx Dly Term B7	300	
196	YTM CW Kick	100	Default values are not altered. Numbers should remain unchanged.
197	YTM Mono Band Kick	2000	
198	YTM Stereo Band Kick	2000	
199	YTM Slew Rate	400	
200	YTM Slew Max	60	
201	YTM Slew Lvlid Cntr	0	
205	YTM Rise; Band 1	15	Minimize power dropouts at the start of band. Adjustment is only effective at fast sweep speeds.
206	YTM Rise; Band 2 A1	25	
207	YTM Rise; Band 2 B1	2	
208	YTM Rise; Band 2 A2	15	
209	YTM Rise; Band 3 A1	70	
210	YTM Rise; Band 3 B1	7	
211	YTM Rise; Band 3 A2	70	
212	YTM Rise; Band 3 B2	7	
213	YTM Rise; Band 3 A3	15	
214	YTM Rise; Band 4	15	
215	YTM Rise; Band 5	15	
216	YTM Rise; Band 6	15	
217	YTM Rise; Band 7	15	

Table 3-3. YTM Calibration Constants and Default Values (3 of 3)

Number	Description	Default Value	Adjustment Description
225	*YTM Gain Band 1	2048	Maximize power over higher 10% of band. Adjust at slow sweep speeds.
226	*YTM Gain Band 2	2048	
227	*YTM Gain Band 3	2048	
228	*YTM Gain Band 4	2048	
229	*YTM Gain Band 5	2048	
230	*YTM Gain Band 6	2048	
231	*YTM Gain Band 7	2048	
238	*YTM Offset Band 1	2048	Maximize power over lower 10% of band. Adjust at slow sweep speeds.
239	*YTM Offset Band 2	2048	
240	*YTM Offset Band 3	2048	
241	*YTM Offset Band 4	2048	
242	*YTM Offset Band 5	2048	
243	*YTM Offset Band 6	2048	
244	*YTM Offset Band 7	2048	
373	YTM Dly Term C Hrm 1	50	
374	YTM Dly Term C Hrm 2	30	
375	YTM Dly Term C Hrm 3	30	
376	YTM Dly Term C Hrm 4	0	
377	YTM Dly Term C Hrm 5	0	
378	YTM Dly Term C Hrm 6	0	
379	YTM Dly Term C Hrm 7	0	
382	YTM Bx Dly Term C1	0	
383	YTM Bx Dly Term C2	0	
384	YTM Bx Dly Term C3	40	
385	YTM Bx Dly Term C4	0	
386	YTM Bx Dly Term C5	0	
388	YTM Bx Dly Term C6	0	
525	Hibernation Time	90	
526	Bandcross 1	42	
527	Bandcross 2	32	
528	Bandcross 3	28	
529	Bandcross 4	50	
530	Bandcross 5	28	
531	Bandcross 6	20	
532	Bandcross 7	20	

YTM Gain Adjustment

Band 1 Adjustment

Note



If the synthesizer has a step attenuator (option 001), the 10 dB fixed attenuator can be eliminated by uncoupling the step attenuator and setting it to 10 dB (use the power menu).

5. On the synthesizer, set:

START **2.3** **GHz** (synthesizers with a lowest start frequency of 10 MHz)

START **2** **GHz** (synthesizers with a lowest start frequency of 2 GHz)

STOP **7** **GHz**

SWEEP TIME **200** **msec**

POWER LEVEL **25** **dBm**

Note that the synthesizer has unlevelled output power.

6. On the oscilloscope, set:

Channel A: 5 mV/Division

Offset: As required

Input Coupling: dc

Input Impedance: 1 M Ω

Channel B: 1 V/Division

Offset: As required

Input Coupling: dc

Input Impedance: 1 M Ω

Sweep Mode: A versus B

Adjust Channel B offset and volts/division for a trace that fills the full horizontal display.

7. Set A12R5 DROOP fully counterclockwise.
8. Set A12S1 switch 5 to OPEN.
9. Adjust A12R69 GAIN to maximize high end power (last two horizontal display divisions).
10. Modify calibration constant #238, YTM Offset; Band 1, to maximize low end power.
11. Increment calibration constant #131, Squegg Clamp Band 1. Power should increase with each increment in the calibration constant. Note the point at which the trace starts to break up, drop out, or there is no further increase in power. Reduce the calibration constant to decrease power by 1 division ($\cong 1.5$ dB) below any indication of trace breakup (see "Adjustment Help"). Figure 3-19 shows an example of a properly adjusted squegg clamp calibration constant (a) and the same adjustment showing a low end power dropout (b).

12. Repeat steps 9 through 11 until the entire band is peaked.

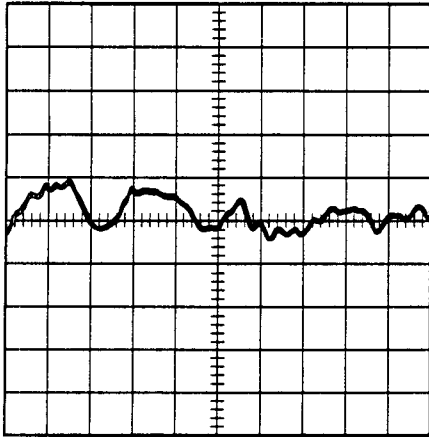

(a) No squегging

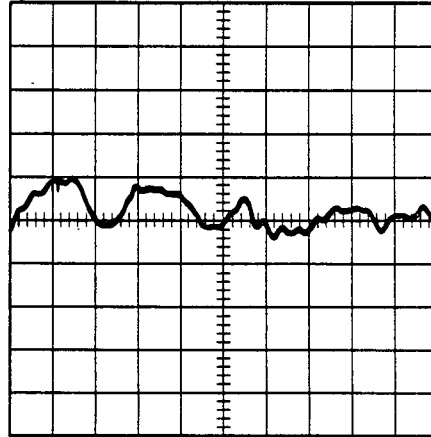

(b) Start of squегging

Figure 3-19. Squегg Clamp Band 1 Adjustment

13. Note the value of calibration constant #238, YTM Offset; Band 1 _____.

Vary this calibration constant ± 50 counts and verify that the power change is uniform across the entire band. If the power change is not uniform, repeat steps 9 through 11 again.

Band 2 Adjustment

14. On the synthesizer, set:

(START) (7) (GHz)

(STOP) (12.5) (GHz)

(CONT) (SWEEP TIME) (200) (msec)

15. Set the oscilloscope vertical position as necessary to display the trace.
16. Modify calibration constant #226, YTM Gain; Band 2, to maximize high end power.
17. Modify calibration constant #239, YTM Offset; Band 2, to maximize low end power.

18. Adjust band 2 SRD bias calibration constants as follows:

- a. Increment calibration constant #106, SRD Bias A; Band 2, to maximize low end power.
- b. Decrement calibration constant #106, SRD Bias A; Band 2, to decrease power by $\cong 1/3$ division (0.5 dB.)
- c. Increment calibration constant #119, SRD Bias B; Band 2, to maximize high end power.
- d. Decrement calibration constant #119, SRD Bias B; Band 2, to decrease power by $\cong 1/3$ division.

19. Increment calibration constant #132, Squegg Clamp Band 2. Power should increase with each increment of the calibration constant. Note the point at which the trace starts to break up, drop out, or there is no further increase in power. Reduce the calibration constant to decrease power by 1 division below where any indication of trace breakup occurs (see "Adjustment Help").

20. Repeat steps 16 thru 19 until the entire band is peaked.

21. Note the value of calibration constant #239, YTM Offset; Band 2 _____.

Vary this calibration constant ± 50 counts and verify that the power change on the analyzer is uniform across the entire band. If not, repeat steps 14 through 20.

Band 3 Adjustment

22. On the synthesizer, set:

(START) (12.5) (GHz)
(STOP) (20) (GHz)
(CONT) (SWEEP TIME) (200) (msec)

23. Set A12R25 B3SL1 fully clockwise.

24. Adjust calibration constant #227, YTM Gain; Band 3, for the dip at the high end (see "Adjustment Help").

25. Modify calibration constant #240, YTM Offset; Band 3, to maximize low end power.

26. Increment calibration constant #133, Squegg Clamp Band 3. Power should increase with each increment of the calibration constant. Note the point at which the trace starts to break up, drop out, or where there is no further increase in power. Reduce the calibration constant by 1 division below where any indication of trace breakup occurs. See figure 3-20 for an example of a properly adjusted trace (a) and the same trace where power has stopped increasing in the part of the low end of the band (b). If squegging does *not* occur, set the squegging clamp to 255.

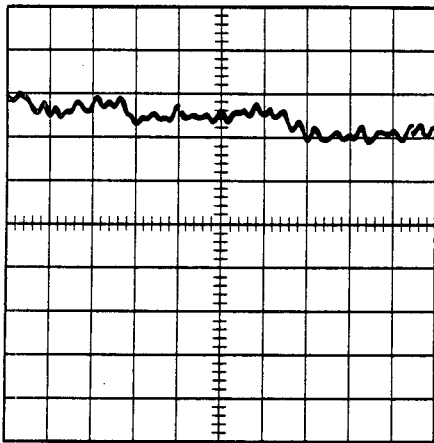

(a) Adjusted for maximum power

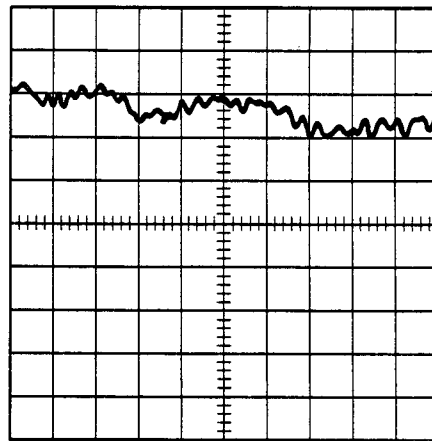

(b) No further increase in power

Figure 3-20. Squegg Clamp Band 3 Adjustment

27. Set the band 3 SRD bias calibration constants as follows:
 - a. Increment calibration constant #120, SRD Bias B; Band 3, to maximize high end power.
 - b. Decrement calibration constant #120, SRD Bias B; Band 3, to decrease power by $\cong 1/3$ division.
 - c. Increment calibration constant #107, SRD Bias A; Band 3, to maximize low end power.
 - d. Decrement calibration constant #107, SRD Bias A; Band 3, to decrease power by $\cong 1/3$ division.
28. Repeat steps 24 thru 27 until power is optimized over the full band. Power is optimized when the SYTM offset adjustment causes a peak in power at the start of the band coincident with a dip in power at the end of the band (see the properly adjusted trace in figure 3-20).

Auto Tracking Verification

29. Record the value of the following calibration constants:

- #225 YTM Gain Band 1 _____
- #226 YTM Gain Band 2 _____
- #227 YTM Gain Band 3 _____
- #228 YTM Gain Band 4 _____
- #229 YTM Gain Band 5 _____
- #230 YTM Gain Band 6 _____
- #231 YTM Gain Band 7 _____

- #238 YTM Offset Band 1 _____
- #239 YTM Offset Band 2 _____
- #240 YTM Offset Band 3 _____
- #241 YTM Offset Band 4 _____
- #242 YTM Offset Band 5 _____
- #243 YTM Offset Band 6 _____
- #244 YTM Offset Band 7 _____

30. Disconnect the coupler from the A28 SYTM. Reconnect the high band detector cable to the CR1 high band detector. Connect the semi-rigid cable W56 between the A28 SYTM and the A33 amplifier/switch. Connect the power meter through a 10 dB attenuator to the RF OUTPUT connector.
31. Initiate auto tracking on the synthesizer as follows. Terminate the RF OUTPUT with a good 50Ω impedance match such as a 10 dB attenuator or a power sensor (not necessary for synthesizers with a step attenuator.) Press:

USER CAL [**Tracking Menu**] [**Auto Track**]

Watch while the synthesizer completes auto tracking. Note if auto tracking is particularly slow in any band. If auto tracking fails (an error message is displayed) repeat the gain and offset adjustments for the failed frequency.

32. On the synthesizer, set:

START **2.3** **GHz**
STOP **20** **GHz**
SWEEP TIME **1.5** **sec**
POWER LEVEL **25** **dBm**

33. Manually sweep the full frequency range to find the minimum power point. On the power meter, check that the power at this point is not below the specified maximum leveled power (note that power is attenuated by 10 dB). If it is, check the following:
- a. Check the squegging clamp calibration constant for the respective band. Increase the power if needed by increasing the clamp calibration constant value on the SYTM.

- b. Compare the manually adjusted YTM gain and YTM offset calibration constants (step 29) to the auto tracked calibration constants. A large difference in values (several hundred counts) indicates a possible misadjustment. The auto tracking values are correct. Big differences indicate where improvements in adjustment technique can be made.
34. Set the synthesizer power level to the specified maximum leveled power. Check for ALC oscillations or level squegging.
- a. The SRD bias A or B calibration constants for the affected band might eliminate oscillation. The problem is with the A term if the oscillations are near the beginning of the band. It is with the B term if the oscillations are near the end of the band. SRD bias has a range. It can be underbiased which causes level squegging. If so, increase the value of the SRD bias calibration constants and repeat the adjustment.
 - b. If the SRD bias calibration constants have no effect, check the ALC Mod Gain calibration constant for the appropriate band.
35. Try single sweeps over various frequency ranges such as 5 GHz to 20 GHz or 10 GHz to 20 GHz. Set the sweep times to greater than 200 msec for single-band and less than 1.5 sec for multi-band sweeps since delay compensation has not yet been adjusted. Problems here are typically associated with sphere heating while awaiting the start of sweep trigger. If necessary adjust the squegging clamp calibration constant for the appropriate band.

Tracking

36. If all the YTM Offset calibration constants are high (around 3000 or higher), the YO frequency at the start of each band is off by 100 MHz or more. Use the spectrum analyzer and the Stop After Bandcross feature to determine the frequency at start of band.
37. If the auto tracking routine is very slow in a particular band, there is probably a problem with the YTM gain and offset calibration constants. Repeat the manual YTM Tracking adjustment.
38. Disconnect the semi-rigid cable W56 from between the A28 SYTM and the A33 amplifier/switch. Connect the power meter through a 10 dB attenuator to the SYTM output connector.
39. On the synthesizer, set:
 - (START) (2.3) (GHz) (synthesizers with a lowest start frequency of 10 MHz)
 - (START) (2) (GHz) (synthesizers with a lowest start frequency of 2 GHz)
 - (STOP) (7) (GHz)
 - (CONT) (SWEEP TIME) (200) (msec)
 - a. Note the minimum power point on the oscilloscope display.
 - b. Press SWEEP (MENU) [*Manual Sweep*] (asterisk on) and manually sweep the synthesizer to the minimum power point from step a.
40. If the minimum power point, read from the power meter, exceeds 12 dBm, decrease the value of the band 1 squegg clamp calibration constant #131 until this power level is reached.
41. Repeat steps 39 and 40 for the following start and stop frequencies, squegg clamp calibration constants, and power levels shown in table 3-4.

Table 3-4. Minimum Power Point Settings

Frequency (GHz)	Squegg Clamp Calibration Constant	Power Level
7 to 12.5	132	12 dBm
12.5 to 20	133	12 dBm*
* If power is not high enough, set the squegg clamp calibration constant to 255.		

42. Disconnect the power meter. Reconnect channel A through the 10:1 probe, and the coupler to the SYTM output. Connect the 10 dB attenuator to the coupler output. Connect the high band ALC detector cable to the detector on the coupler.

Single Band SYTM Delay and Risetime Compensation

43. On the synthesizer, set:

(START) (2.3) (GHz) (synthesizers with a lowest start frequency of 10 MHz)

(START) (2) (GHz) (synthesizers with a lowest start frequency of 2 GHz)

(STOP) (7) (GHz)

(CONT) (SWEEP TIME) (0) (msec)

(POWER LEVEL) (25) (dBm)

Note that the synthesizer has unlevelled output power.

Band 1 Adjustment

Note



Since YTM Rise; Band 1 is set to the default value, a spike at the beginning of band 1 may be present.

44. Adjust calibration constant #144, YTM Dly Term A Hrm 1, to maximize power for the low end of band 1. Set the calibration constant for the middle of the peaked range.
45. Adjust calibration constant, #157 YTM Dly Term B Hrm 1, to maximize power for the high end of band 1. Set the calibration constant for the middle of the peaked range.
46. Adjust calibration constant #205, YTM Rise; Band 1, to minimize power dropout at the start of band 1.
47. Switch between the fastest sweep time and 200 msec sweep time and check that power changes less than 2/3 division ($\cong 1$ dB.) If not, repeat steps 44 and 45.
48. On the synthesizer, set:
(SWEEP TIME) (0) (msec)
49. Press (SINGLE) several times to initiate several sweeps. If a drop in power greater than 1 division occurs when in single sweep, increase the A term of the delay adjustment #144 to put the A term at the high end of the peak (see "Adjustment Help").

Band 2 Adjustment

50. On the synthesizer, set:

(START) (7) (GHz)
(STOP) (12.5) (GHz)
(CONT) (SWEEP TIME) (0) (msec)

51. Adjust calibration constant #145, YTM Dly Term A Hrm 2, to maximize power for the low end of band 2.
52. Adjust calibration constant #158, YTM Dly Term B Hrm 2, to maximize power for the high end of band 2.
53. Adjust calibration constant #208, YTM Rise; Band 2 A2, to maximize power dropout at the low end of band 2.
54. Switch between the fastest sweep time (0 msec) and 200 msec sweep time and check that power changes less than $\cong 2/3$ division. If not, repeat steps 51 and 52.
55. On the synthesizer, set:

(SWEEP TIME) (0) (msec)

56. a. Press (SINGLE) several times to initiate several sweeps. Note any drop in power.
- b. Press (SINGLE) (RF ON/OFF). Then press (RF ON/OFF) again (LED on) and note the drop in power.
- c. The power loss noted in step a can be no smaller than the power loss noted in step b. If the step a power loss is greater than the step b power loss by 1 division ($\cong 1.5$ dB), increase the A term of the delay adjustment #145 to put the A term at the high end of the peak (see "Adjustment Help").

Band 3 Adjustment

57. On the synthesizer, set:

(START) (12.5) (GHz)
(STOP) (20) (GHz)
(CONT) (SWEEP TIME) (0) (msec)

58. Adjust calibration constant #146, YTM Dly Term A Hrm 3, to maximize power for the low end of band 3.
59. Adjust calibration constant #159, YTM Dly Term B Hrm 3, to maximize power for the high end of band 3 as follows:
- a. Offset the calibration constant enough to cause an extreme power loss in band 3.
- b. Slowly adjust the calibration constant for the dip at the high end of the band (see "Adjustment Help"). The difference between the peak and the dip may be less than $1/3$ division.

60. Adjust calibration constant #213, YTM Rise; Band 3 A3, to minimize power dropout at the start of band 3.
61. Switch between the fastest sweep time (0 msec) and 200 msec sweep time and check that power changes less than 2/3 division ($\cong 1$ dB). If necessary, repeat steps 58 and 59.
62. On the synthesizer, set:

(SWEEP TIME) (0) (msec)
63. a. Press (SINGLE) several times to initiate several sweeps. Note any drop in power.
 - b. Press (SINGLE) (RF ON/OFF). Then press (RF ON/OFF) again (LED on) and note the drop in power.
 - c. The power loss noted in step a can be no smaller than the power loss noted in step b. If the step a power loss is greater than the step b power loss by 1 division ($\cong 1.5$ dB), increase the A term of the delay adjustment #146 to put the A term at the high end of the peak (see "Adjustment Help").

Multiband SYTM Delay and Risetime Compensation

Note



Power dropouts at the start of each band are typically removed with the YTM Risetime calibration constants. These will be adjusted later.

64. On the synthesizer, set:

(START) (12) (GHz)
 (STOP) (20) (GHz)
 (CONT) (SWEEP TIME) (0) (msec)
 (POWER LEVEL) (25) (dBm)

Note



Synthesizer markers are set to identify the bandcross frequencies (7.0 and 12.5 GHz). You can also identify bandcrosses by temporarily removing the cable from the Z-AXIS BLANK/MKRS connector on the synthesizer rear panel. Make sure this cable is connected when making adjustments.

65. On the synthesizer, set:

(MARKER) [Marker M1] (12.5) (GHz) (asterisk on)

66. Adjust calibration constant #172, YTM Bx Dly Term A3, to maximize power at the low end of band 3.

67. Adjust calibration constant #185, YTM Bx DLY Term B3, as follows:
- Offset the calibration constant enough to cause an extreme power loss in band 3.
 - Slowly adjust the calibration constant for the dip at the high end of the band (see "Adjustment Help").
68. Switch between the fastest sweep time (0 msec) and 200 msec sweep time and check that power changes less than 2/3 division ($\cong 1$ dB). If the change in power is greater than 2/3 division, readjust the A term of the delay adjustment #172 for low end problems, or the B term of the delay adjustment #185 for high end problems.
69. On the synthesizer, set:
- SWEEP TIME** **0** **msec**
70. Press **SINGLE** several times to initiate several sweeps. If a drop in power greater than 1 division occurs when in single sweep, increase the A term of the delay adjustment #172 to put the A term at the high end of the peak (see "Adjustment Help").
71. On the synthesizer, set:
- START** **7** **GHz**
- CONT** **SWEEP TIME** **0** **msec**
72. Adjust calibration constant #171, YTM Bx Dly Term A2, to maximize power at the start of band 2 (start of sweep).
73. Adjust calibration constant #184, YTM Bx Dly Term B2, to maximize power at the end of band 2.
74. Adjust calibration constant #211, YTM Rise; Band 3 A2, to minimize power dropout at the start of band 3. Figure 3-21 shows the calibration constant correctly adjusted (a) and misadjusted (b).

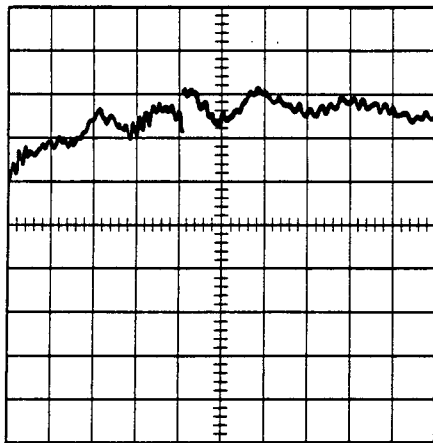

(a) Correctly adjusted

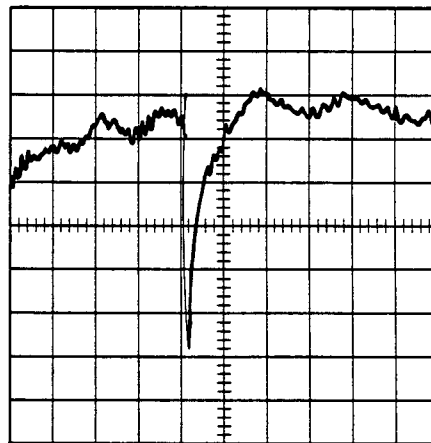

(b) Misadjusted

Figure 3-21. Band 3 A2 YTM Risetime Adjustment

75. Switch between the fastest sweep time (0 msec) and 500 msec sweep time and check that power changes less than 2/3 division ($\cong 1$ dB) across both bands. If the change is greater than 2/3 division, readjust the appropriate delay term.
76. On the synthesizer, set:
 -
77. Press several times to initiate several sweeps. If a drop in power greater than 1 division occurs when in single sweep, readjust the appropriate delay term for the location of the problem.
78. On the synthesizer, set:
 -
 -
79. Adjust calibration constant #212, YTM Rise; Band 3 B2, to minimize power dropout at the start of band 3. Do *not* allow the value of this calibration constant to be greater than 1/5 the value of #211, YTM Rise; Band 3 A2.

80. Press **(SINGLE)** several times to initiate several sweeps. If a drop in power greater than 1/3 division occurs when in single sweep, readjust the appropriate delay or risetime term for the location of the problem.
81. On the synthesizer, set:
- (START)** **(2.3)** **(GHz)**
- (CONT)** **(SWEEP TIME)** **(0)** **(msec)**
- (MARKER)** **[Marker M2]** **(7)** **(GHz)** (asterisk on)
82. Adjust calibration constant #170, YTM Bx Dly Term A1, to maximize power at the start of band 1.
83. Adjust calibration constant #183, YTM Bx Dly Term B1, to maximize power at the high end of band 1.
84. Adjust calibration constant #209, YTM Rise; Band 3 A1, to minimize power dropout at the start of band 3.
85. Adjust calibration constant #206, YTM Rise; Band 2 A1, to minimize power dropout at the start of band 2.
86. Switch between the fastest sweep time (0 msec) and 1 sec sweep time and check that power changes less than 2/3 division ($\cong 1$ dB) across all bands. If the change is greater than 2/3 division, readjust the appropriate delay term.
87. On the synthesizer, set:
- (SWEEP TIME)** **(0)** **(msec)**
88. Press **(SINGLE)** several times to initiate several sweeps. Note the drop in power in all bands. If a drop in power greater than 1 division occurs when in single sweep, readjust the appropriate delay or risetime term for the location of the problem.
89. On the synthesizer, set:
- (START)** **(5)** **(GHz)**
- (CONT)**
- (SWEEP TIME)** **(0)** **(msec)**
90. Adjust calibration constant #210, YTM Rise; Band 3 B1, to minimize power dropout at the start of band 3. Do *not* allow the value of this calibration constant to be greater than 1/5 the value of #209, YTM Rise; Band 3 A1.
91. Press **(SINGLE)** several times to initiate several sweeps. If a drop in power greater than 1 division occurs when in single sweep, readjust the appropriate delay or risetime term.
92. Reinstall the RF deck in the instrument, removing the extender board and extender cable, and reconnecting W56 between the A28 SYTM and the A33 amplifier/switch.

93. For the following start and stop frequencies:

0.01 to 20 GHz (synthesizers with a lowest start frequency of 10 MHz)

2 to 20 GHz (synthesizers with a lowest start frequency of 2 GHz)

4.5 to 18 GHz

10 to 20 GHz

2 to 14.5 GHz

Compare sweeps of 0 msec and 1 sec and also single sweeps at fast speed. If a power drop of 0.5 division or greater is noted, readjust the appropriate calibration constant.

94. Connect the power meter/sensor through the 10 dB attenuator to the synthesizer's RF OUTPUT. For the frequencies listed in step 93, manually sweep the synthesizer and compare the minimum power point from the power meter to the specified maximum leveled power. The minimum power point must meet or exceed this level.

95. If this is the last calibration constant you will be adjusting, see "Calibration Constants" to store the calibration constants as protected data (in EEPROM).

Related Performance Tests

Maximum Leveled Power

In Case Of Difficulty

1. See "Adjustment Help" in this procedure.
2. Verify the oscilloscope ALC board calibration. When calibrated, the voltage on the oscilloscope is scaled to $\cong 33$ mV/dB.
3. If you are unable to meet the maximum leveled power specifications, set A29R2 (amplifier detector gain adjustment) fully clockwise. Finish the SYTM adjustment. Perform the amplifier detector gain adjustment.
4. See "TROUBLESHOOTING" in the *Assembly-Level Repair* manual.

11. LOW POWER SRD BIAS

Description and Procedure

The synthesizer is set up for a low power 2 to 20 GHz sweep. The oscilloscope is used to monitor the ALC assembly integrator level signal while the synthesizer is forward sweeping in bands 2 and 3. Then the A9 pulse board MIN adjustment is made to minimize the integrator level signal for both bands.

1. Connect the equipment as shown in figure 3-22. Preset all instruments and let them warm up for at least one hour.

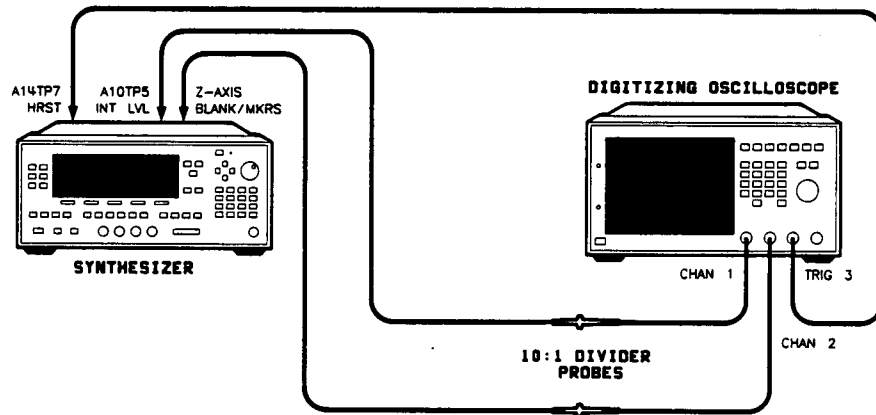

Figure 3-22. Low Power SRD Bias Test Setup

2. On the synthesizer, set:

START **7** **GHz**

STOP **20** **GHz**

RF ON/OFF On (amber light is on)

POWER **MENU** [*Uncoupl Atten*] (option 001 only)

POWER LEVEL **-20** **dBm**

SWEEP TIME Fastest sweep time

3. On the oscilloscope, set:

CHANNEL 1:

Display	On
Volts/Division	0.1V
Input Coupling	dc
Input Impedance	1 M Ω

CHANNEL 2:

Display	On
Preset	TTL
Input Impedance	1 M Ω

TIMEBASE:

Time/Division	2.2 ms
Delay	-2 ms
Delay Reference	At left
Sweep	Triggered

TRIGGER:

Trigger Mode	Events
Trigger	After negative edge
Trigger Source	Trig 3
Trigger	On 1 events
Trigger	Of negative edge
Trigger	On channel 2

DISPLAY:

Display Mode	Repetitive
Averaging	Off
Display Time	0.2s

4. Adjust the oscilloscope channel 1 offset and timebase settings as necessary to center the traces on the display.
5. Save the oscilloscope setup in register 1.
6. On the oscilloscope, set:

Timebase:

Time/Division	3 ms
---------------	------

Trigger:

Trigger	On 2 events
---------	-------------

7. Adjust the oscilloscope channel 1 offset and timebase settings as necessary to center the traces on the display.
8. Save the oscilloscope setup in register 2. Recall register 1.
9. Alternate between registers 1 and 2 and adjust A9R105 (MIN) for the minimum overall voltage as shown in figure 3-23. See figure 3-24 for the location of A9R105.

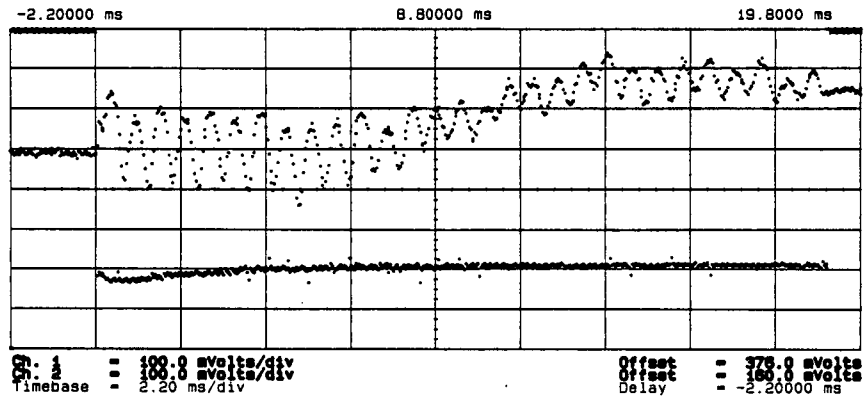

Figure 3-23. A9 Pulse Board MIN Adjustment

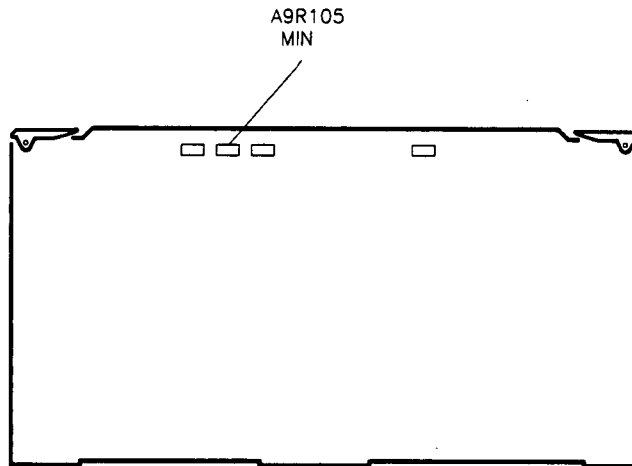

Figure 3-24. A9R105 Location

Related Performance Tests

Power Flatness
Power Accuracy
AM Accuracy

In Case of Difficulty

See "TROUBLESHOOTING" in the *Assembly-Level Repair* manual.

12. AMPLIFIER DETECTOR GAIN

Description and Procedure

No test equipment is required for this procedure.

In band 1, excessive gain in the amplifier detector will reduce the effective ALC dynamic range. This adjustment sets the amplifier gain level to the minimum required to achieve maximum leveled power. As a result, the ALC modulator maintains its full dynamic range. This adjustment is switched on only for band 1 operation.

1. Install the RF deck on the extender board with all RF cables connected. Use the extender board and extender cable provided in the service kit and see "DISASSEMBLY AND REPLACEMENT PROCEDURES" in the *Assembly-Level Repair* manual for instructions.
2. Preset the synthesizer and allow it to warm up for at least one hour.
3. To achieve peak power, initiate auto tracking on the synthesizer as follows. Terminate the RF OUTPUT with a good 50 ohm impedance match such as a 10 dB attenuator or a power sensor (not necessary for synthesizers with a step attenuator.) Press:

USER CAL **[Tracking Menu]** **[Auto Track]**

Wait for the synthesizer to complete auto tracking before continuing to the next step.

4. Preset the amplifier detector gain adjustment A29R2 fully clockwise (multi-turn potentiometer). See figure 3-25 for the A29R2 location.

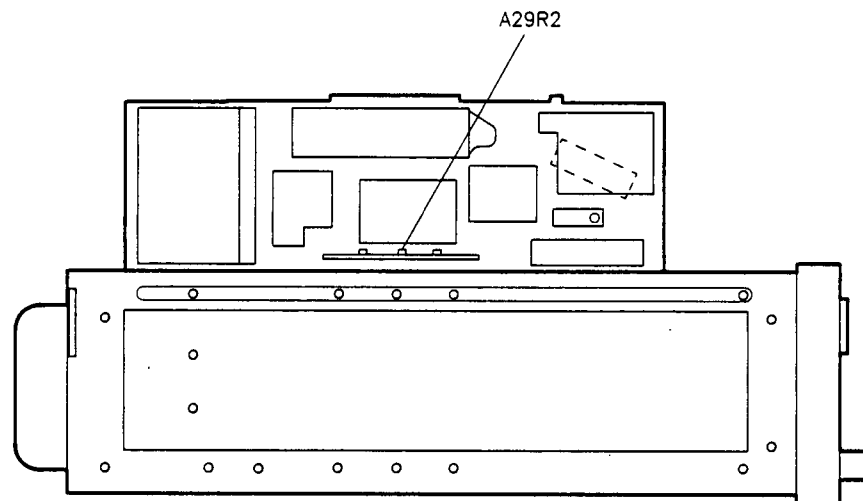

Figure 3-25. A29R2 Location

5. On the synthesizer, set:

(START) (2.3) (GHz)

(STOP) (7) (GHz)

6. Press (POWER LEVEL) and increase power using the rotary knob until the unlevelled message is displayed. (If the synthesizer will not unlevel, set the power level at the maximum settable power and continue with step 7.)

Decrease power until the unlevelled message turns off.

7. Adjust A29R2 counterclockwise until the synthesizer displays the unlevelled message.

Adjust A29R2 clockwise until the unlevelled message turns off.

8. Turn off power to the synthesizer, disconnect line power, and reinstall the RF deck (see "DISASSEMBLY AND REPLACEMENT PROCEDURES").

Related Performance Tests

Maximum Levelled Power

In Case of Difficulty

See "TROUBLESHOOTING" in the *Assembly-Level Repair* manual.

13. MODULATOR OFFSET AND GAIN

Description and Procedure

In this procedure, the ALC modulation offset and gain calibration constants are adjusted to linearize the ALC modulator response to the ALC power level reference voltage. Default values are entered for the modulator offset calibration constants and internal firmware is activated to set the modulator gain calibration constants. The synthesizer is then set for a power sweep across the entire leveled ALC range (-20 to $+17$ dBm). The integrator level signal on the ALC board is monitored to verify linearity. If necessary, the modulator offset values are modified.

1. Connect the equipment as shown in 3-26. Preset the instruments and let them warm up for at least one hour.

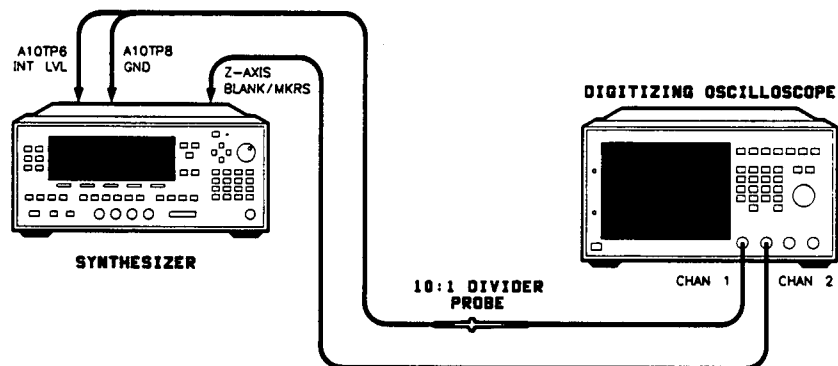

Figure 3-26. Modulator Offset and Gain Adjustment Setup

2. On the synthesizer, set:
SERVICE [Adjust Menu] [Calib Menu]

3. Set the ALC offset calibration constants to the default values given in table 3-5.
 Select **[Select Cal]**. Using the numeric keypad, enter the number of the first calibration constant in table 3-5. Terminate your entry with the **(ENTER)** key.
 Select **[Modify Cal]**. Use the numeric keypad to enter the corresponding default value in table 3-5. Terminate your entry with the **(ENTER)** key.
4. Using the up/down arrow keys, select each of rest of the calibration constants in table 3-5 and set their default values by entering the value on the numeric keypad. Terminate your entry with the **(ENTER)** key.

Table 3-5. ALC Offset Calibration Constant Default Values

Calibration Constant	Description	Default Value
315	ALC Mod Ofs; Band 0	100
316	ALC Mod Ofs; Band 1	100
317	ALC Mod Ofs; Band 2	180
318	ALC Mod Ofs; Band 3	180
319	ALC Mod Ofs; Band 4	150
320	ALC Mod Ofs; Band 5	150
321	ALC Mod Ofs; Band 6	150
322	ALC Mod Ofs; Band 7	150

5. On the synthesizer, set:
(SERVICE) [Adjust Menu] [AssyAdj Menu] [A10 Adj Menu] [A10 Mod Gain]
 The synthesizer will measure, calculate, and store the modulator gain calibration constants.
 When the adjustment is completed the following message appears on the display:

Modulator Gain Cal Completed
 Calibration constants were modified.
6. If this is the last calibration constant you will be adjusting, see "Calibration Constants" to store the calibration constants as protected data (in EEPROM).
7. Connect the oscilloscope as shown in figure 3-26.

8. On the oscilloscope, set:

Channel 1:
Display On
Volts/Division 50 mV
Offset As necessary
Input Coupling dc
Input Impedance 1 M Ω

Channel 2:
Display On
Volts/Division 2V
Input Coupling dc
Input Impedance 1 M Ω

Timebase:
Time/Division 10 ms
Delay 5 ms
Delay Reference At left
Sweep Triggered

Trigger:
Trigger Mode Edge
Trigger Source Channel 2
Trigger Level 2V
Trigger Slope Negative

Display:
Display Mode Repetitive
Averaging On
Number of Averages 2

9. On the synthesizer, set:

CW **1** **GHz**

SPAN **0** **GHz**

POWER LEVEL **-** **20** **dBm** *

POWER **MENU** **POWER SWEEP** **37** **dB**

SWEEP TIME **100** **msec**

USER CAL [*Tracking Menu*] [*Peak RF Always*]

* For synthesizer with step attenuators, do not set the power level in this step. Instead set:

POWER **MENU** [*Uncoupl Atten*] [*Set Atten*] **0** **dB** **POWER LEVEL** **-** **20** **dBm**

10. Adjust the oscilloscope timebase so the Z-axis input goes high at the right edge of the display. This signal is low during the power sweep.

11. Change the value of the band 0 calibration constant #315 as needed for a signal variation less than 200 mV during the power sweep (while Z-axis is low).
12. Set the synthesizer to each of the CW frequencies in table 3-6 and repeat step 11 for the corresponding calibration constant.

Table 3-6. CW Frequencies and Calibration Constants

CW Frequencies (GHz)	Calibration Constants
5.0	#316 Band 1
9.0	#317 Band 2
19.0	#318 Band 3

Related Performance Tests

AM Bandwidth

In Case of Difficulty

1. Verify that the synthesizer does not go unlevelled during the sweep.
2. See "TROUBLESHOOTING" in the *Assembly-Level Repair* manual.

14. ALC POWER LEVEL ACCURACY

Description and Procedure

This adjustment sets the absolute power accuracy in each frequency band at a CW frequency. The digital ALC calibration array is loaded with zeroes for the 0 dB attenuator setting to eliminate any power offset from this source. Calibration constants set the power accuracy at four power levels. A potentiometer sets the power accuracy at an 18 dBm level in the low band (not applicable for all models).

Note



This adjustment procedure zeros the digital ALC calibration array at the 0 dB attenuator setting. The "Power Flatness" adjustment must be performed after this procedure.

1. Preset the equipment shown in figure 3-27 and let them warm up for at least one hour. Do *not* connect the power sensor to the synthesizer RF OUTPUT yet.

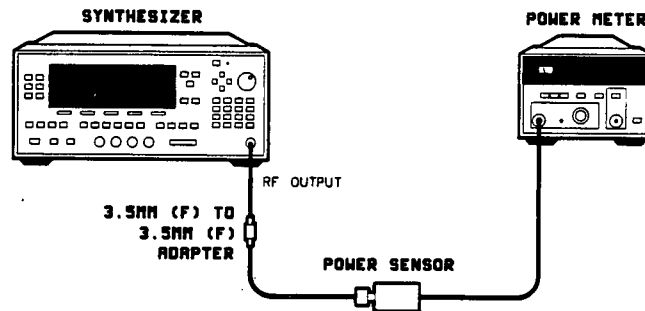

Figure 3-27. Power Accuracy Adjustment Setup

2. Zero and calibrate the power meter/sensor and set the power meter to dBm mode. Connect the power sensor to the synthesizer's RF OUTPUT.

Set the CAL FACTOR % for the power sensor 1 GHz calibration factor.

3. On the synthesizer, set:

USER CAL [Tracking Menu] [Peak RF Always] (asterisk on)

POWER **MENU** [Uncoupl Atten] (option 001 only)

- On the synthesizer, zero the digital ALC calibration for the 0 dB attenuator setting for all frequency ranges:

SERVICE [Adjust Menu] [DigALC Menu]

[AtnStep To Cal] 0 dB

[Cal Freq Range Lo Band] [ALC Cal Array (Atn, Freq) Zero] (not applicable for all models)

[Cal Freq Range Hi Band] [ALC Cal Array (Atn, Freq) Zero]

Note



The default values given in the next step are a general starting point. If the current ALC power accuracy is within 1 dB, fewer repetitions are required if you start with the existing calibration constants unchanged.

- Set the default values given in table 3-7 into the corresponding ALC calibration constants. On the synthesizer, set:

SERVICE [Adjust Menu] [Calib Menu]

[Select Cal] Enter the number of the calibration constant from table 3-7 and terminate the entry with **ENTER**.

[Modify Cal] Enter the default value from table 3-7 and terminate the entry with **ENTER**.

Table 3-7. ALC Calibration Constants and Default Values

ALC Calibration Constant	Default Value
Low Band 0.01 to 2.4 GHz (not applicable for all models)	
#265 LVL DAC Ofs Lo Bnd	150
#252 LVL DAC Gain Lo Bnd	0
#284 ALC Det Ofs; Lo	128
#293 ALC Log Brkpt; Lo	128
High Band 2.3 to 20 GHz	
#264 LVL DAC Ofs Hi Bnd	0
#251 LVL DAC Gain Hi Bnd	0
#283 ALC Det Ofs; Hi	128
#292 ALC Log Brkpt; Hi	128

Low Band ALC Power Accuracy Adjustment (not applicable for all models)

- On the synthesizer, set:

CW 1 GHz

7. On the synthesizer, set:
SERVICE [*Adjust Menu*] [*Calib Menu*]
8. On the synthesizer, set:
POWER LEVEL First power level in table 3-8
9. Select the first calibration constant in table 3-8:
[Select Cal] 265 ENTER
10. On the synthesizer, select [*Modify Cal*] and, using the rotary knob, modify the calibration constant so that the power meter and the power level setting are the same.
11. Repeat steps 8 through 10 for each power level and calibration constant given in table 3-8.

Table 3-8. Power Level and Calibration Constant Adjustment

Power Level (dBm)	Calibration Constant Adjustment
0.0	#265 LVL DAC Ofc Lo Bnd
-10.0	#252 LVL DAC Gain Lo Bnd
-20.0	#284 ALC Det Ofc; Lo
+10.0	#293 ALC Det Log Brkpt; Lo

12. Repeat steps 8 through 11 until the power accuracy for each calibration constant is within ± 0.05 dBm.

High Band Power Accuracy Adjustment

13. On the synthesizer, set:
CW 10 GHz
SERVICE [*Adjust Menu*] [*Calib Menu*]
14. On the power meter, set the CAL FACTOR % for the power sensor 10 GHz calibration factor.
15. On the synthesizer, set:
POWER LEVEL First power level in table 3-9
16. Select the first calibration constant in table 3-9:
[Select Cal] 264 ENTER
17. On the synthesizer, select [*Modify Cal*] and, using the rotary knob, modify the calibration constant so that the power meter and the power level setting are the same.
18. Repeat steps 15 through 17 for each power level and calibration constant given in table 3-9.

19. Repeat steps 15 through 18 until the power accuracy for each calibration constant is within ± 0.05 dBm.

Table 3-9. Power Level and Calibration Constant Adjustment

Power Level (dBm)	Calibration Constant Adjustment
0.0	#264 LVL DAC Ofs Hi Bnd
-10.0	#251 LVL DAC Gain Hi Bnd
-20.0	#283 ALC Det Ofs; Hi
+10.0	#292 ALC Det Log Brkpt; Hi

20. On the synthesizer, set:

POWER LEVEL **18** **dBm**

Adjust A10R125, +20 DBM, until the power meter and the power level setting are the same. Figure 3-28 shows the location of A10R125.

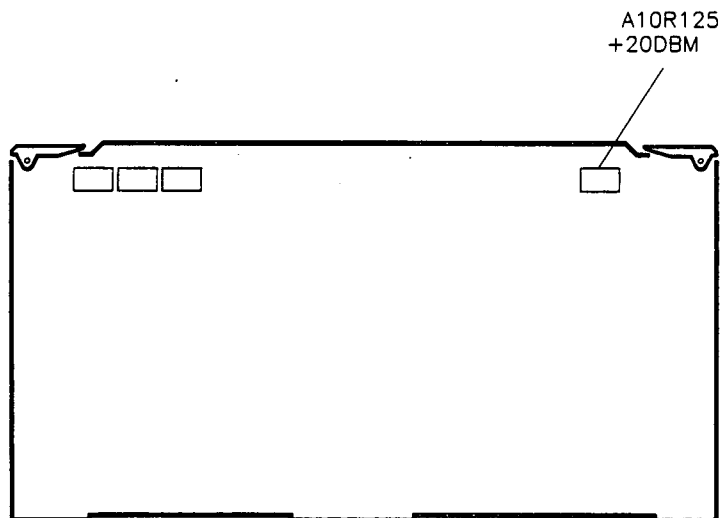

Figure 3-28. A10R125 Location

21. If this is the last calibration constant you will be adjusting, see "Calibration Constants" in this manual to store the calibration constants as protected data (in EEPROM).

Related Performance Tests

Power Accuracy

In Case of Difficulty

1. Verify that the synthesizer output power is leveled at all power settings.
2. See "TROUBLESHOOTING" in the *Assembly-Level Repair* manual.

15. POWER FLATNESS

Description and Procedure

In this procedure, the synthesizer measures and corrects power flatness. The synthesizer controls the power meter via HP-IB while the power meter is measuring the RF output. For each synthesizer frequency band and a 0 dB attenuator setting, control is given to the synthesizer to measure and correct power flatness.

Note



This adjustment requires an HP 437B Power Meter. The correct power sensor calibration factors must be loaded and selected. This procedure cannot be run with a controller on the HP-IB, nor can it be run from a front panel emulator. For option 003 instruments, see "Automated Tests" in this manual.

1. Preset the instruments shown in figure 3-29. Do *not* connect the power sensor to the synthesizer RF OUTPUT yet. Let both instruments warm up for at least one hour.

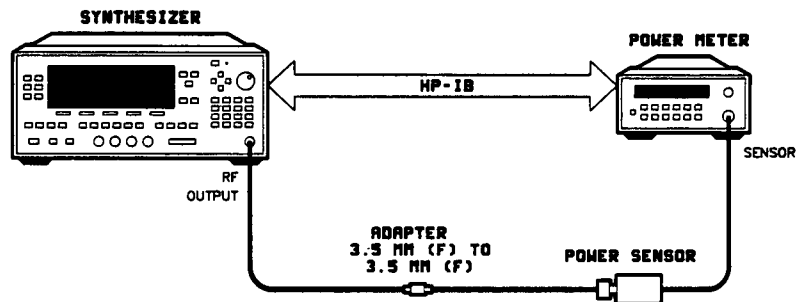

Figure 3-29. Power Flatness Adjustment Setup

Low Band Power Flatness (not applicable for all models)

2. On the synthesizer, set:

[SERVICE] **[Adjust Menu]** **[DigALC Menu]**

[Cal Freq Range Lo Bnd] (asterisk on)

[AtnStep to Cal] **[0]** **[dB]**

3. Load and select the calibration factors for the correct power sensor for this frequency band into the power meter. Refer to the power meter manual for instructions.

Zero and calibrate the power meter then connect the power sensor to the synthesizer RF OUTPUT.

4. On the synthesizer, select [*Pwr Mtr ALC Cal*].

The synthesizer measures power flatness and calculates a new flatness array for the frequency band and attenuator setting.

5. On the synthesizer, select [*SAVE*] and continue to the next step.

High Band Power Flatness

6. Load and select the calibration factors for the correct power sensor for this frequency band into the power meter. Refer to the power meter manual for instructions.

Zero and calibrate the power meter then connect the power sensor to the synthesizer RF OUTPUT.

7. On the synthesizer, set:
[Cal Freq Range Hi Band] (asterisk on)
8. Repeat steps 3 through 5.

Related Performance Tests

Power Flatness

In Case of Difficulty

1. The HP 437B Power Meter must be used. Correct calibration factors must be loaded and selected.
2. Make sure that the only HP-IB connection is between the synthesizer and the power meter. No controller is allowed on the bus.
3. See "TROUBLESHOOTING" in the *Assembly-Level Repair* manual.

16. AM ACCURACY

Description and Procedure

This procedure consists of three adjustments. Calibration constant #277, AM Offset, is adjusted for no change in RF output power when AM is enabled but no voltage is applied. EXP AM CAL is adjusted for a -10 dB change in power when -1.00V is applied and AM 10 dB/V is selected. LIN AM CAL is adjusted so that a -0.80V AM input (100 %/V AM selected) causes the RF output to decrease to 4.00% of its initial value.

1. Turn on the instruments shown in figure 3-30 and let them warm up for at least one hour.
2. Zero and calibrate the power meter/sensor.
3. Connect the equipment as shown in figure 3-30.

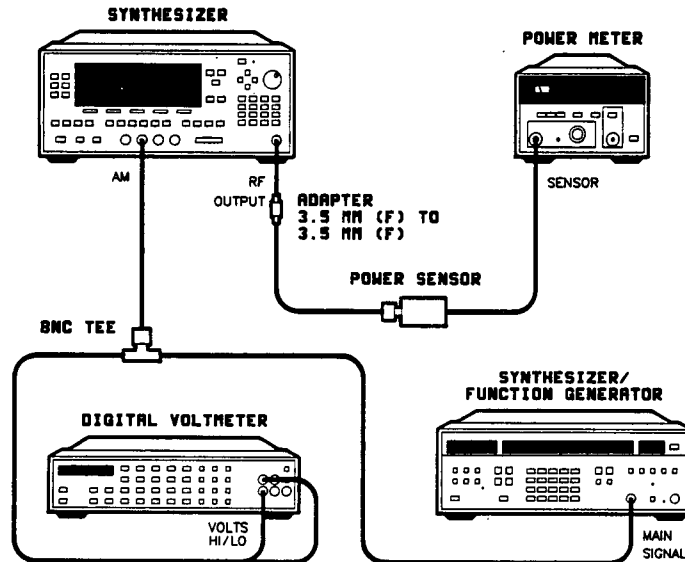

Figure 3-30. AM Accuracy Adjustment Setup

4. Set the function generator for a 0V dc rear panel output (the instrument front panel output is connected to the synthesizer's AM input.)

5. On the synthesizer, set:

CW 5 GHz

POWER LEVEL - 15 dBm

AM Offset

6. Set the power meter to read relative power (dB).
7. On the synthesizer, set:
MOD [**AM On/Off 100%/V**] (asterisk on)
8. Adjust calibration constant #277, AM Offset, for a 0 dB reading on the power meter. Set:
SERVICE [**Adjust Menu**] [**Calib Menu**]
[Select Cal] **277** **ENTER**
[Modify Cal] Use the rotary knob to adjust the calibration constant for a 0 dB reading on the power meter.

Log AM Accuracy

9. Set the power meter to measure absolute log power (dBm).
10. On the synthesizer, set:
POWER LEVEL **0** **dBm**
MOD [**AM On/Off 100%/V**] (asterisk off)
11. Set the function generator to the front panel output.
12. Set the power meter to read relative power (dB).
13. Set the function generator to $-1.0V$ dc offset. Verify the correct voltage on the DVM.
14. On the synthesizer, set:
[AM On/Off 10dB/V] (asterisk on)
15. Adjust A10R35, EXP AM CAL, for a -10 dB power meter reading. See figure 3-31 for the location of A10R35.

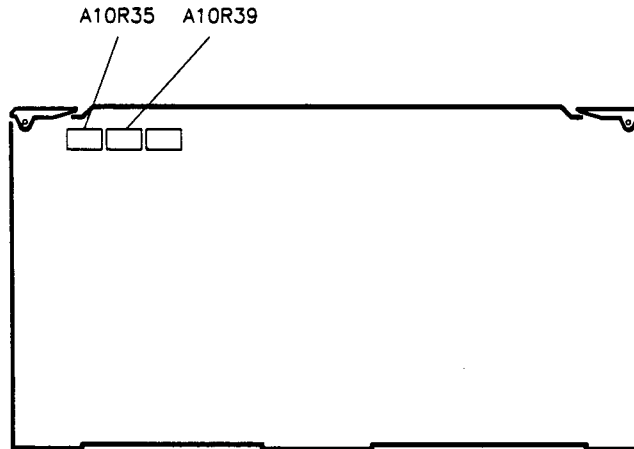

Figure 3-31. A10R35 and A10R39 Locations

Linear AM Accuracy

16. On the synthesizer, set:

[AM On/Off 10dB/V] (asterisk off)

POWER LEVEL 5 dBm

17. Set the power meter to measure linear mode (watts).

18. For power meters without a relative linear mode, adjust the synthesizer power level for a 3.16 mW power meter reading.

For power meters with relative linear mode (%), set the power meter to relative.

19. Set the function generator for a $-0.8V$ dc offset. Verify the correct voltage on the DVM.

20. On the synthesizer, set:

MOD [AM On/Off 100%/V] (asterisk on)

21. Adjust A10R39, LIN AM CAL, for a 0.126 mW (4.00% relative) reading. See figure 3-30 for the location of A10R39.

Related Performance Tests

AM Accuracy

In Case of Difficulty

See "TROUBLESHOOTING" in the *Assembly-Level Repair* manual.

17. AM DELAY

Description and Procedure

In the ALC loop, the integrator input from the ALC detector is delayed (phase shifted from the reference input) through the ALC modulator, RF path, and ALC detector. Because of this, amplitude modulation can peak the AM frequency response. In this adjustment, you set the delay in the reference input equal to the delay in the input from the ALC detector.

The synthesizer is set to maximum leveled power at a CW frequency, with amplitude modulation at the maximum rate. Monitoring the INT LVL signal (the integrator output), adjust the AM DELAY to minimize any ac voltage present.

1. Preset the instruments shown in figure 3-32 and let them warm up for at least one hour.

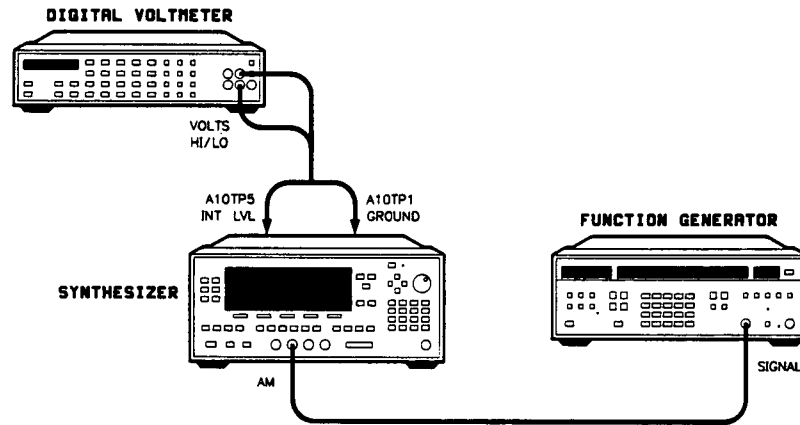

Figure 3-32. AM Delay Adjustment Setup

2. To achieve peak power, turn on RF peaking. Press:
USER CAL **[Tracking Menu]** **[Peak RF Always]** (asterisk on)
3. Connect the equipment as shown in figure 3-32.
4. On the synthesizer, set:
CW **10** **GHz**
POWER LEVEL Set to 3 dB below maximum specified leveled power.
MOD **[AM On/Off 100%/V]** (asterisk on)

Note



The function generator should have a 50Ω output for an accurate output. If necessary, use a BNC tee and monitor the output level while the function generator is connected to the AM input.

5. On the function generator, set:

Function:	Sinewave
Frequency:	100 kHz
DC Offset:	0V
Output:	Front panel
Amplitude	600 mV p-p

6. Adjust A10R55 (see figure 3-33) for a minimum ac voltage reading on the DVM.

Note



You should expect to see very small changes in voltage.

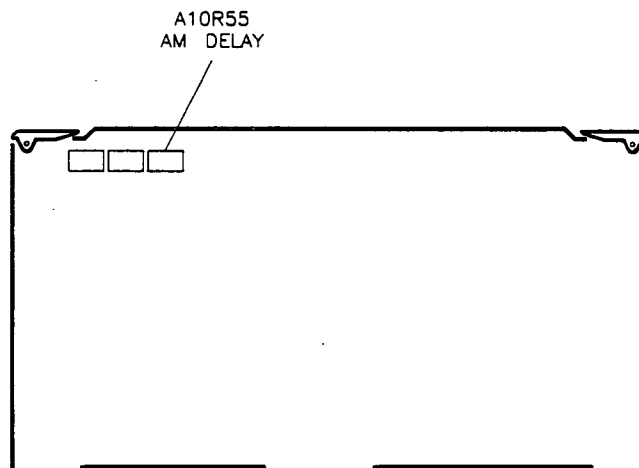

Figure 3-33. AM Delay Adjustment Location

Related Performance Tests

AM Bandwidth

In Case of Difficulty

See "TROUBLESHOOTING" in the *Assembly-Level Repair* manual.

18. PULSE DELAY

Description and Procedure

In this procedure the rising edges of the pulsed input and the amplifier/detector output are aligned to ensure an output to the SRD bias generator during the pulse.

The synthesizer is set up for external pulse modulation at its narrowest width. A9R76 is set fully counter-clockwise for maximum delay of the pulsed input. As the potentiometer is adjusted clockwise, the pulse is shifted. The integrated dc output of the pulsed input and the amplifier/detector output is monitored. The dc level reaches maximum where the two signals are aligned. The rising edges of the two signals align just before the dc level starts to decrease from the maximum level.

Caution



A voltage more negative than -0.5V on the PULSE input connector will damage the synthesizer.

1. Preset the equipment shown in figure 3-34 and let them warm up for at least one hour.

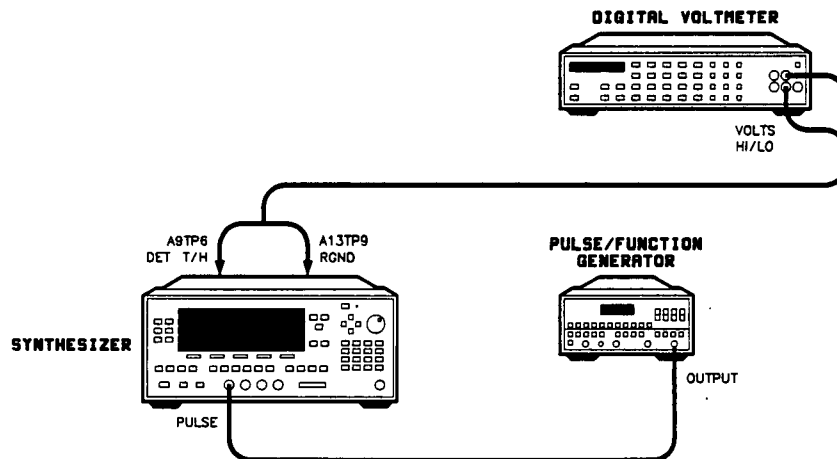

Figure 3-34. Pulse Delay Adjustment Setup

2. To achieve peak power, turn on RF peaking. Press:
USER CAL [**Tracking Menu**] [**Peak RF Always**] (asterisk on)
3. Connect the equipment as shown in figure 3-34.

4. On the synthesizer, set:

CW **5** **GHz**

POWER LEVEL Set to maximum specified leveled power.

ALC [**Leveling Mode Search**] (asterisk on)

MOD [**Pulse On/Off External**] (asterisk on)

5. On the pulse generator, set:

Pulse Width: 100 ns

Pulse Period: 1 μ s

Pulse Amplitude: 0 to +5V

6. Preset A9R76 (see figure 3-35) fully counter-clockwise.

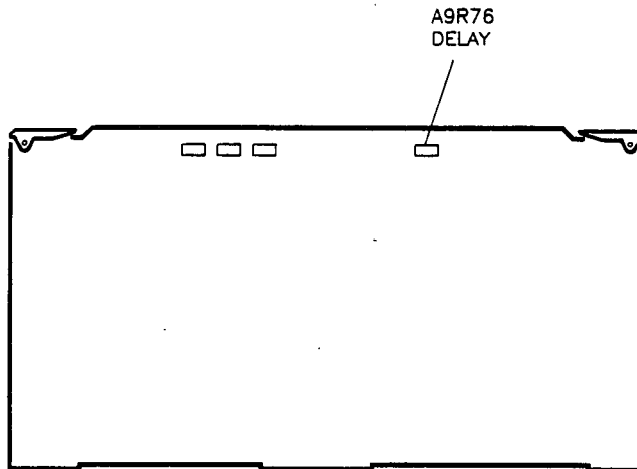

Figure 3-35. Pulse Delay Adjustment Location

7. Note the voltage reading on the DVM: _____

8. Adjust A9R76 clockwise just until the voltage starts to drop. Set the adjustment slightly counter-clockwise from the point at which the voltage starts to drop.

Performance Tests

Pulse Performance

In Case of Difficulty

1. Make sure the pulse input has sufficient amplitude to pulse the RF.
2. See "TROUBLESHOOTING" in the *Assembly-Level Repair* manual.

19. FM GAIN

Description and Procedure

This adjustment sets the gain on the FM driver assembly to match the YO FM coil sensitivity, and to provide a 10 MHz/V FM input sensitivity. The function generator is set to provide FM at a 1 MHz rate and a 2.404 MHz deviation. This corresponds to a modulation index of 2.404, which should result in no power in the carrier. FM gain is adjusted to minimize the RF output power.

1. Connect the equipment as shown in figure 3-36. Preset all instruments and let them warm up for at least one hour.

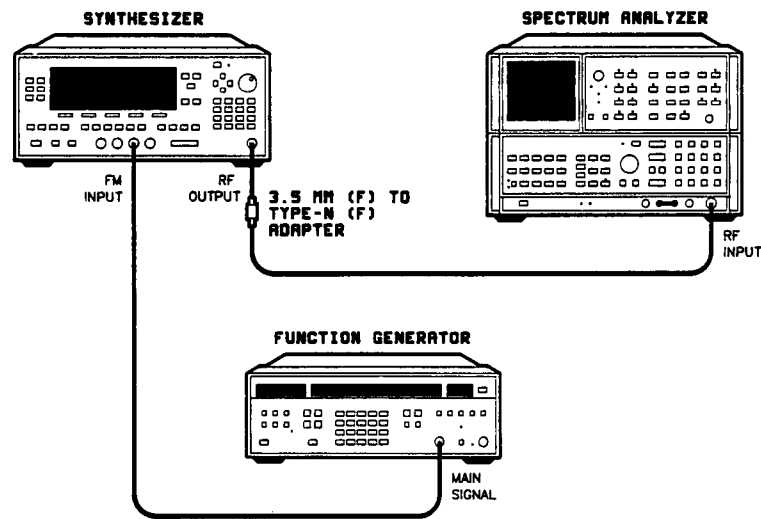

Figure 3-36. FM Gain Adjustment Setup

Note



The function generator specified in "EQUIPMENT REQUIRED" is accurate enough to set the amplitude without using a DVM. If you use a different function generator, use a wide bandwidth DVM, such as an HP 3458A, to accurately set the voltage.

2. On the function generator, set:

Function: Sinewave
Frequency: 1 MHz
DC Offset: 0V
Amplitude: 480.8 mVp-p (169.96 mV rms)

3. On the spectrum analyzer, set:

Reference Level: 0 dBm
Attenuator: Auto
Center Frequency: 5 GHz
Frequency Span: 50 kHz
Resolution BW: 3 kHz
Video BW: 1 kHz
Sweep Time: Auto
Sweep: Continuous

4. On the synthesizer, set:

CW **5** **GHz**

MOD **[FM On/Off AC]** **10 MHz/V** (asterisk on)

5. Adjust A11R55 (see figure 3-37) for a minimum amplitude signal on the spectrum analyzer.

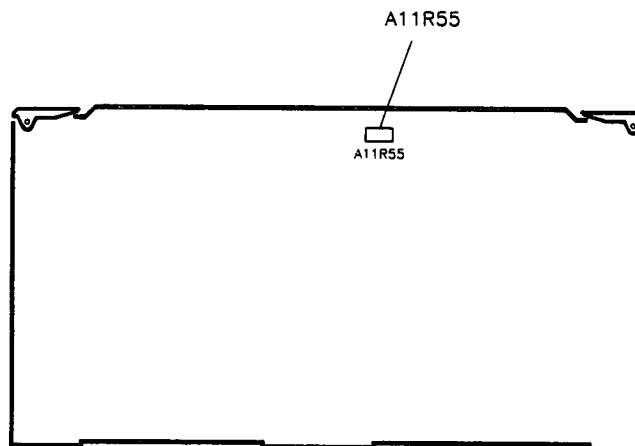

Figure 3-37. FM Gain Adjustment Location

Performance Tests

Self-tests
FM Accuracy

In Case of Difficulty

1. Verify the function generator output (amplitude and frequency) with an oscilloscope. Use a BNC tee with the function generator connected to the FM input.
2. See "TROUBLESHOOTING" in the *Assembly-Level Repair* manual.

20. SQUARE WAVE SYMMETRY

Description and Procedure

Use this adjustment to set the synthesizer modulation (27.78 square wave) for equal RF on/off periods. Using a power meter, adjust calibration constants for an RF output power decrease of 3 dB when the synthesizer square wave is on.

Note



If you are not familiar with how to adjust calibration constants, refer to the "Calibration Constants" section of this chapter.

1. Turn on the equipment shown in figure 3-38 and let them warm up for at least one hour.

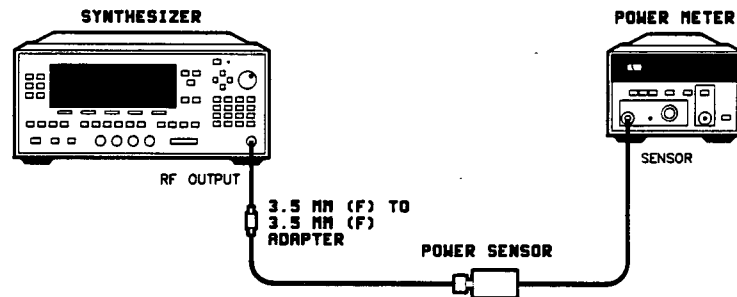

Figure 3-38. Square Wave Symmetry Adjustment Setup

2. On the power meter:
Zero and calibrate the power meter/power sensor.
3. Connect the equipment as shown in figure 3-38 and preset the instruments.
3. On the synthesizer, set:
4. Set the power meter for a relative measurement (dB).

5. On the synthesizer, set:

MOD [**Pulse On/Off Scalar**] (asterisk on)

Adjust calibration constant #330 (Slow Sym High Band) for a -3.0 dB reading on the power meter. Press:

SERVICE [**Adjust Menu**] [**Calib Menu**] [**Select Cal**]

Use the rotary knob or arrow keys to select calibration constant #330. Select [**Modify Cal**] and use the rotary knob to adjust the calibration constant.

On the synthesizer, set:

MOD [**Pulse On/Off Scalar**] (asterisk off)

CW **1** **GHz**

6. On the power meter, set:

Absolute power mode (dBm) (to measure the power level at 1 GHz).

Relative measurement mode (dB).

7. On the synthesizer, set:

MOD [**Pulse On/Off Scalar**] (asterisk on)

Adjust calibration constant #329 (Slow Sym Low Band) for a -3 dB reading on the power meter. Press:

SERVICE [**Adjust Menu**] [**Calib Menu**] [**Select Cal**]

Use the rotary knob or arrow keys to select calibration constant #329. Select [**Modify Cal**] and use the rotary knob to adjust the calibration constant.

8. If this is the last calibration constant you will be adjusting see "Calibration Constants" to store the calibration constants as protected data (in EEPROM).

Related Performance Tests

Self-tests
Pulse On/Off Ratio
Pulse Performance

In Case of Difficulty

See "TROUBLESHOOTING" in the *Assembly-Level Repair* manual.

Calibration Constants

Calibration Constants

INTRODUCTION

This section contains the following information on calibration constants and how to use them:

Topic	Page
Definition	3-88
Memory Areas	3-88
Checksum Verification	3-89
Calibration Constant Password	3-89
Changing Working Data Calibration Constants	3-91
Saving Working Data Calibration Constants	3-92
Loading Protected Data Calibration Constants	3-92
Loading Default Data Calibration Constants	3-92
Calibration Constant Descriptions	3-93

DEFINITION

Calibration constants are data which describe your individual instrument. Calibration constants contain serial number prefix, hardware configuration, and board revision information. Calibration constants also contain calibration information specific to the operation of each instrument that is used to make sure that the instrument meets specifications.

Note



Changing calibration constants can cause your instrument to *not* meet specifications.

MEMORY AREAS

The synthesizer has three memory areas reserved for calibration constants:

Working Data

Working data is the set of calibration constants accessed during normal operation, and contains the calibration information required for optimum instrument performance. Working data is stored in RAM, and is maintained by a battery.

Protected Data

Protected data resides in EEPROM. This calibration data is essentially the same as working data, but is not dependent on a battery. If the synthesizer's checksum test fails, or if the battery fails and working data is lost, the synthesizer copies protected data values into working data RAM.

Default Data

Default data resides in UVEPROM. This data differs from working and protected data in that it cannot be changed. This data represents a typical synthesizer, and is not optimized for your instrument. The default calibration constants are a starting point for calibration. The synthesizer will probably *not* meet specifications. The synthesizer uses default data if a problem exists in both working and protected data or if you select [*Default Cal*] in the calibration utility menu.

CHECKSUM VERIFICATION

At instrument power, on the calibration constants stored in RAM are added and compared with the checksum value. If the two values match, the current calibration constants are maintained in RAM.

If the RAM checksum does not verify, the calibration constants are loaded into RAM from EEPROM. These calibration constants are added and compared with their checksum value. If the two values match, these calibration constants (from EEPROM) are maintained in RAM.

If the RAM checksum still does not verify, the default calibration constants are loaded into RAM from UVEPROM. A message is displayed on the synthesizer indicating that the default calibration constants are in use. The synthesizer will probably *not* meet performance specifications. All the performance tests should be run.

CALIBRATION CONSTANT PASSWORD

The synthesizer is shipped with a factory-set password. A password disables access to the adjustment menu unless the password is entered (see "Entering a Password"). Calibration constants *cannot* be manually altered without accessing the adjustment menu.

The following is the factory-set password: 8360

You can set a new password. See "Setting a Password".

You can eliminate the password. See "Disabling a Password".

If you have forgotten the password, or if you require access to the calibration constant adjustments for calibration purposes and do not know the password, see "Bypassing the Password".

Entering a Password

An asterisk on the **[Disable Adjust]** softkey in the service menu indicates that a password is set. In order to access the adjustment menu you must enter that password:

1. On the synthesizer, set:

(SERVICE) **[Adjust Menu]**

The following message is displayed: ENTER PASSWORD: 0

2. Enter the correct password using the numeric keypad and press **(ENTER)**

The asterisk on the **[Disable Adjust]** softkey turns off.

3. Select **[Adjust Menu]** again to access the adjustment menu.

Entering the password allows permanent access to the adjustment menu, even if line power is cycled. To disable access again, set another password.

Disabling a Password

If you wish to eliminate a password (either the factory-set password or one you set yourself), perform the following:

1. On the synthesizer, set:

SERVICE **[Disable Adjust]**

The following message is displayed: ENTER PASSWORD: 0

2. Enter the current password using the numeric keypad and press **ENTER**

The asterisk on the **[Disable Adjust]** softkey turns off.

Disabling the password allows permanent access to the adjustment menu, even if line power is cycled.

Setting a Password

If a password is already set on the synthesizer and you wish to change it, first follow the "Disabling a Password" procedure. This eliminates the current password. Then continue with this procedure.

If no password is set on the synthesizer (there is no asterisk on the **[Disable Adjust]** softkey), and you wish to set a password, perform the following:

1. On the synthesizer, set:

SERVICE **[Disable Adjust]**

The following message is displayed: SET PASSWORD: 0

2. Enter the desired password using the numeric keypad. Up to 14 numeric digits are allowed. Terminate the entry by pressing: **ENTER**
3. A warning message is displayed informing you that the adjustment menus will no longer be accessible. To verify that you do wish to set the password, select **[Yes, Confirm]**

The asterisk on the **[Disable Adjust]** softkey turns on, indicating the password is set.

Bypassing the Password

If you require access to the adjustment menu for calibration purposes, a password is set, and you do not know the password, perform the following:

1. Turn off line power to the synthesizer.
2. Open A15S1 switch 5 (set the switch to the "1" position).

3. Turn on line power to the synthesizer and press **(SERVICE)**

The asterisk on the **[Disable Adjust]** softkey turns off enabling access to the adjustment menu.

When access to the adjustment menu is no longer desired, enable the previously set password. Perform the following:

4. Turn off line power to the synthesizer.
5. Close A15S1 switch 5 (set the switch to the "0" position).
6. Turn on line power to the synthesizer and press **(SERVICE)**

The asterisk on the **[Disable Adjust]** softkey turns on indicating that you cannot access the adjustment menu.

If you have forgotten the password and wish to set a new one, perform steps 1 through 3 and then steps 7 through 10:

7. On the synthesizer, select **[Disable Adjust]**.

The following message is displayed: SET PASSWORD: 0

8. Enter the desired password using the numeric keypad. Up to 14 numeric digits are allowed. Terminate the entry by pressing: **(ENTER)**
9. A warning message is displayed informing you that the adjustment menus will no longer be accessible. To verify that you do wish to set the password, select **[Yes, Confirm]**
10. Another warning message is displayed informing you that the A15S1 switch 5 is set open. Complete steps 4 through 6 to close the switch and enable the password.

CHANGING WORKING DATA CALIBRATION CONSTANTS

If you need to modify the working data calibration constants, the following procedure accesses the calibration constants and lets you change them.

1. On the synthesizer, set:
(SERVICE) [Adjust Menu] [Calib Menu]

2. Select **[Select Cal]**

Enter the number of the calibration constant you wish to change using the up/down arrow keys, the rotary knob, or the numeric keypad. Terminate numeric keypad entries by pressing **(ENTER)**.

3. Select **[Modify Cal]**

Change the value of the calibration constant using the right/left arrow keys, the rotary knob, or the numeric keypad. Terminate numeric keypad entries by pressing **(ENTER)**.

4. Exit the calibration menu using the **(PRIOR)** key or pressing **(PRESET)**.

SAVING WORKING DATA CALIBRATION CONSTANTS

In some adjustment procedures you will change working data calibration constants. The following procedure stores the calibration constants as protected data (in EEPROM).

1. On the synthesizer, set:

SERVICE [Adjust Menu] [Calib Menu] [Cal Util Menu]

2. Select [Save Cal]

A warning is displayed informing you that changing the calibration constants may drastically affect instrument performance. To verify that you do wish to save the new calibration constants, select [yes]

The working data calibration constants are now stored as protected data (in EEPROM).

3. Exit the calibration utility menu using the **PRIOR** key or pressing **PRESET**.

LOADING PROTECTED DATA CALIBRATION CONSTANTS

If your working data calibration constants have been altered or deleted, the following procedure loads the protected calibration constants from EEPROM into working data memory.

1. On the synthesizer, set:

SERVICE [Adjust Menu] [Calib Menu] [Cal Util Menu]

2. Select [Recall Cal]

A warning is displayed informing you that changing the calibration constants may drastically affect instrument performance. To verify that you do wish to recall the protected data calibration constants, select [yes]

The protected data calibration constants are now loaded into working data.

3. Exit the calibration utility menu using the **PRIOR** key or pressing **PRESET**.

LOADING DEFAULT DATA CALIBRATION CONSTANTS

If you want to use the generic synthesizer calibration constants as working data, the following procedure loads the default calibration constants from UVEPROM into working data memory.

1. On the synthesizer, set:

SERVICE [Adjust Menu] [Calib Menu] [Cal Util Menu]

2. Select **[Default Cal]**

A warning is displayed informing you that changing the calibration constants may drastically affect instrument performance. To verify that you do wish to recall the default calibration constants, select **[yes]**

The default data calibration constants are now loaded into working data.

3. Exit the calibration utility menu using the **(PRIOR)** key or pressing **(PRESET)**.

CALIBRATION CONSTANT DESCRIPTIONS

Table 3-9 provides the following information for each calibration constant:

- The calibration constant number in ascending order.
- The calibration constant name. An asterisk indicates that this calibration constant is adjusted by an automated adjustment.
- The range of realistic adjustment (adjustment outside of the range may be possible but will probably cause the synthesizer to be severely misadjusted) or the default value (some calibration constants are set to a default value and are not adjustable).
- The related adjustment procedure, manual, automated, or front panel, that adjusts that calibration constant.

Note



Blank calibration constants are reserved for future use.

Table 3-9. Calibration Constant Descriptions

Number	Description	Range or Default	Related Adjustment
1	Identifier Response	2	
2	Dwell After RF On	2	
3	User Configuration	0	
4	Lockout Features	0	
5	Display Field Lock	0	
6	Retrace Dwell Time	0	
7			
8			
9			
10			
11			
12			
13			
14			
15			
16	Production Info 1	0	
17	Production Info 2	0	
18	Production Info 3	0	
19	Production Info 4	0	
20	Production Info 5	0	
21	Lock Dwell Time	2	
22	Max Ph Lk Wait	100	
23	YO Slew Rate	500	
24	YO Kick Max	6000	
25	YO Settle Rate	20	
26			
27			
28			
29			
30			
31			
32			
33			
34			
35			
36	YO Dly Term A Bnd 0	400 to 800	YO Delay Adjustment
37	YO Dly Term A Bnd 1	400 to 800	YO Delay Adjustment
38	YO Dly Term A Bnd 2	400 to 800	YO Delay Adjustment
39	YO Dly Term A Bnd 3	400 to 800	YO Delay Adjustment
40	YO Dly Term A Bnd 4	400 to 800	YO Delay Adjustment
41	YO Dly Term A Bnd 5	400 to 800	YO Delay Adjustment
42	YO Dly Term A Bnd 6	400 to 800	YO Delay Adjustment
43	YO Dly Term A Bnd 7	400 to 800	YO Delay Adjustment
44			
45			

Table 3-9. Calibration Constant Descriptions

Number	Description	Range or Default	Related Adjustment
46			
47			
48			
49			
50	YO Dly Term B Bnd 0	300 to 700	YO Delay Adjustment
51	YO Dly Term B Bnd 1	300 to 700	YO Delay Adjustment
52	YO Dly Term B Bnd 2	300 to 700	YO Delay Adjustment
53	YO Dly Term B Bnd 3	300 to 700	YO Delay Adjustment
54	YO Dly Term B Bnd 4	300 to 700	YO Delay Adjustment
55	YO Dly Term B Bnd 5	300 to 700	YO Delay Adjustment
56	YO Dly Term B Bnd 6	300 to 700	YO Delay Adjustment
57	YO Dly Term B Bnd 7	300 to 700	YO Delay Adjustment
58			
59			
60			
61			
62			
63			
64			
65			
66			
67			
68			
69			
70			
71			
72	*CW Offset	-500 to +500	YO Driver Gain And Linearity
73	YO Off Ver; Band 0	0	
74	YO Off Ver; Band 1	0	
75	YO Off Ver; Band 2	0	
76	YO Off Ver; Band 3	0	
77	YO Off Ver; Band 4	0	
78	YO Off Ver; Band 5	0	
79	YO Off Ver; Band 6	0	
80	YO Off Ver; Band 7	0	
81			
82			
83			
84			
85			
86			
87	YO Swp Ver; Band 0	0	
88	YO Swp Ver; Band 1	0	
89	YO Swp Ver; Band 2	0	
90	YO Swp Ver; Band 3	0	

Table 3-9. Calibration Constant Descriptions

Number	Description	Range or Default	Related Adjustment
91	YO Swp Ver; Band 4	0	
92	YO Swp Ver; Band 5	0	
93	YO Swp Ver; Band 6	0	
94	YO Swp Ver; Band 7	0	
95			
96			
97			
98			
99			
100			
101	YTM Temp Coefficient	0	
102			
103			
104			
105	SRD Bias A; Band 1	30 to 230	SYTM Adjustments
106	SRD Bias A; Band 2	30 to 230	SYTM Adjustments
107	SRD Bias A; Band 3	30 to 230	SYTM Adjustments
108	SRD Bias A; Band 4	30 to 230	SYTM Adjustments
109	SRD Bias A; Band 5	30 to 230	SYTM Adjustments
110	SRD Bias A; Band 6	30 to 230	SYTM Adjustments
111	SRD Bias A; Band 7	30 to 230	SYTM Adjustments
112			
113			
114			
115			
116			
117			
118	SRD Bias B; Band 1	30 to 230	SYTM Adjustments
119	SRD Bias B; Band 2	30 to 230	SYTM Adjustments
120	SRD Bias B; Band 3	30 to 230	SYTM Adjustments
121	SRD Bias B; Band 4	30 to 230	SYTM Adjustments
122	SRD Bias B; Band 5	30 to 230	SYTM Adjustments
123	SRD Bias B; Band 6	30 to 230	SYTM Adjustments
124	SRD Bias B; Band 7	30 to 230	SYTM Adjustments
125			
126			
127			
128			
129			
130			
131	Squegg Clamp Band 1	40 to 200	SYTM Adjustments
132	Squegg Clamp Band 2	50 to 255	SYTM Adjustments
133	Squegg Clamp Band 3	50 to 255	SYTM Adjustments
134	Squegg Clamp Band 4	50 to 255	SYTM Adjustments
135	Squegg Clamp Band 5	50 to 255	SYTM Adjustments

Table 3-9. Calibration Constant Descriptions

Number	Description	Range or Default	Related Adjustment
136	Squegg Clamp Band 6	50 to 255	SYTM Adjustments
137	Squegg Clamp Band 7	50 to 255	SYTM Adjustments
138			
139			
140			
141			
142			
143			
144	YTM Dly Term A Hrm 1	600 to 2000	SYTM Adjustments
145	YTM Dly Term A Hrm 2	600 to 2500	SYTM Adjustments
146	YTM Dly Term A Hrm 3	600 to 3000	SYTM Adjustments
147	YTM Dly Term A Hrm 4	600 to 2500	SYTM Adjustments
148	YTM Dly Term A Hrm 5	600 to 3000	SYTM Adjustments
149	YTM Dly Term A Hrm 6	600 to 3000	SYTM Adjustments
150	YTM Dly Term A Hrm 7	600 to 3000	SYTM Adjustments
151			
152			
153			
154			
155			
156			
157	YTM Dly Term B Hrm 1	200 to 500	SYTM Adjustments
158	YTM Dly Term B Hrm 2	200 to 500	SYTM Adjustments
159	YTM Dly Term B Hrm 3	200 to 500	SYTM Adjustments
160	YTM Dly Term B Hrm 4	200 to 500	SYTM Adjustments
161	YTM Dly Term B Hrm 5	200 to 500	SYTM Adjustments
162	YTM Dly Term B Hrm 6	200 to 500	SYTM Adjustments
163	YTM Dly Term B Hrm 7	200 to 500	SYTM Adjustments
164			
165			
166			
167			
168			
169			
170	YTM Bx Dly Term A 1	600 to 2000	SYTM Adjustments
171	YTM Bx Dly Term A 2	600 to 2500	SYTM Adjustments
172	YTM Bx Dly Term A 3	600 to 3000	SYTM Adjustments
173	YTM Bx Dly Term A 4	600 to 2500	SYTM Adjustments
174	YTM Bx Dly Term A 5	600 to 3000	SYTM Adjustments
175	YTM Bx Dly Term A 6	600 to 3000	SYTM Adjustments
176	YTM Bx Dly Term A 7	600 to 3000	SYTM Adjustments
177			
178			
179			
180			

Table 3-9. Calibration Constant Descriptions

Number	Description	Range or Default	Related Adjustment
181			
182			
183	YTM Bx Dly Term B 1	200 to 500	SYTM Adjustments
184	YTM Bx Dly Term B 2	200 to 500	SYTM Adjustments
185	YTM Bx Dly Term B 3	200 to 500	SYTM Adjustments
186	YTM Bx Dly Term B 4	200 to 500	SYTM Adjustments
187	YTM Bx Dly Term B 5	200 to 500	SYTM Adjustments
188	YTM Bx Dly Term B 6	200 to 500	SYTM Adjustments
189	YTM Bx Dly Term B 7	200 to 500	SYTM Adjustments
190			
191			
192			
193			
194			
195			
196	YTM CW Kick	100	SYTM Adjustments
197	YTM Mono Band Kick	2000	SYTM Adjustments
198	YTM Stereo Band Kick	2000	SYTM Adjustments
199	YTM Slew Rate	400	SYTM Adjustments
200	YTM Slew Max	60	
201	YTM Slew Lvid Cntr	0	
202			
203			
204			
205	YTM Rise; Band 1	1 to 20	SYTM Adjustments
206	YTM Rise; Band 2 A1	20 to 25	SYTM Adjustments
207	YTM Rise; Band 2 B1	1 to 4	SYTM Adjustments
208	YTM Rise; Band 2 A2	10 to 20	SYTM Adjustments
209	YTM Rise; Band 3 A1	5 to 255	SYTM Adjustments
210	YTM Rise; Band 3 B1	0 to 50	SYTM Adjustments
211	YTM Rise; Band 3 A2	5 to 255	SYTM Adjustments
212	YTM Rise; Band 3 B2	0 to 50	SYTM Adjustments
213	YTM Rise; Band 3 A3	1 to 20	SYTM Adjustments
214	YTM Rise; Band 4	1 to 50	SYTM Adjustments
215	YTM Rise; Band 5	1 to 50	SYTM Adjustments
216	YTM Rise; Band 6	1 to 50	SYTM Adjustments
217	YTM Rise; Band 7	0	SYTM Adjustments
218			
219			
220			
221			
222			
223			
224			
225	*YTM Gain; Band 1	1500 to 2500	SYTM Adjustments/ Auto Track

Table 3-9. Calibration Constant Descriptions

Number	Description	Range or Default	Related Adjustment
226	*YTM Gain; Band 2	1000 to 2500	SYTM Adjustments/ Auto Track
227	*YTM Gain; Band 3	500 to 2500	SYTM Adjustments/ Auto Track
228	*YTM Gain; Band 4	1000 to 2500	SYTM Adjustments/ Auto Track
229	*YTM Gain; Band 5	500 to 2500	SYTM Adjustments/ Auto Track
230	*YTM Gain; Band 6	500 to 2500	SYTM Adjustments/ Auto Track
231	*YTM Gain; Band 7	500 to 2500	SYTM Adjustments/ Auto Track
232			
233			
234			
235			
236			
237			
238	*YTM Offset; Band 1	1500 to 2500	SYTM Adjustments/ Auto Track
239	*YTM Offset; Band 2	1500 to 3000	SYTM Adjustments/ Auto Track
240	*YTM Offset; Band 3	1500 to 3000	SYTM Adjustments/ Auto Track
241	*YTM Offset; Band 4	1500 to 3000	SYTM Adjustments/ Auto Track
242	*YTM Offset; Band 5	1500 to 3000	SYTM Adjustments/ Auto Track
243	*YTM Offset; Band 6	1500 to 3000	SYTM Adjustments/ Auto Track
244	*YTM Offset; Band 7	1500 to 3000	SYTM Adjustments/ Auto Track
245			
246			
247			
248			
249			
250			
251	*LVL DAC Gain Hi Bnd	-100 to +100	ALC Power Level Accuracy/[Detector Cal]
252	*LVL DAC Gain Lo Bnd	-100 to +100	ALC Power Level Accuracy/[Detector Cal]
253	*LVL DAC Gain Xtal	-100 to +100	[Detector Cal]
254	*LVL DAC Gain 2ndOut	0	
255	*LVL DAC Gain PwrMtr	-100 to +100	

Table 3-9. Calibration Constant Descriptions

Number	Description	Range or Default	Related Adjustment
256	*LVL DAC Gain Module	-100 to +100	
257	*LVL DAC Gain ALC Off	0	
258			
259			
260			
261			
262			
263			
264	*LVL DAC Ofs Hi Bnd	-50 to +300	ALC Power Level Accuracy [Detector Cal]
265	*LVL DAC Ofs Lo Bnd	100 to 250	ALC Power Level Accuracy [Detector Cal]
266	*LVL DAC Ofs Xtal	-1000 to +1000	[Detector Cal]
267	*LVL DAC Ofs 2ndOut	0	
268	*LVL DAC Ofs PwrMtr	-100 to +100	
269	*LVL DAC Ofs Module	-100 to +100	
270	*LVL DAC Ofs ALC Off	0	
271			
272			
273			
274			
275			
276			
277	AM Offset	-20 to +20	AM Accuracy
278			
279			
280			
281			
282			
283	*ALC Det Ofs; Hi	100 to 160	ALC Power Level Accuracy/[Detector Cal]
284	*ALC Det Ofs; Lo	100 to 160	ALC Power Level Accuracy/[Detector Cal]
285	*ALC Det Ofs; Xtal	100 to 160	
286	*ALC Det Ofs; 2nd Out	100 to 160	
287			
288			
289			
290			
291			
292	*ALC Log Brkpt; Hi	0 to 255	ALC Power Level Accuracy/[Detector Cal]
293	*ALC Log Brkpt; Lo	0 to 255	ALC Power Level Accuracy/[Detector Cal]
294	*ALC Log Brkpt; Xtal	0 to 255	

Table 3-9. Calibration Constant Descriptions

Number	Description	Range or Default	Related Adjustment
295	*ALC Log Brkpt; 2nd	0 to 255	
296			
297			
298			
299			
300			
301	*ALC Mod Gain; Band 0	100 to 200	Modulator Offset And Gain
302	*ALC Mod Gain; Band 1	100 to 200	Modulator Offset And Gain
303	*ALC Mod Gain; Band 2	40 to 100	Modulator Offset And Gain
304	*ALC Mod Gain; Band 3	40 to 100	Modulator Offset And Gain
305	*ALC Mod Gain; Band 4	40 to 100	Modulator Offset And Gain
306	*ALC Mod Gain; Band 5	40 to 100	Modulator Offset And Gain
307	*ALC Mod Gain; Band 6	40 to 100	Modulator Offset And Gain
308	*ALC Mod Gain; Band 7	40 to 100	Modulator Offset And Gain
309			
310			
311			
312			
313			
314			
315	ALC Mod Ofs; Band 0	50 to 150	Modulator Offset And Gain
316	ALC Mod Ofs; Band 1	50 to 150	Modulator Offset And Gain
317	ALC Mod Ofs; Band 2	150 to 220	Modulator Offset And Gain
318	ALC Mod Ofs; Band 3	150 to 220	Modulator Offset And Gain
319	ALC Mod Ofs; Band 4	100 to 200	Modulator Offset And Gain
320	ALC Mod Ofs; Band 5	100 to 200	Modulator Offset And Gain
321	ALC Mod Ofs; Band 6	100 to 200	Modulator Offset And Gain
322	ALC Mod Ofs; Band 7	100 to 200	Modulator Offset And Gain
323			
324			
325			
326			
327			
328			
329	Slow Sym Low Band	100 to 160	Square Wave Symmetry
330	Slow Sym High Band	100 to 160	Square Wave Symmetry
331	Attenuator Sw Point	-1000	
332			
333			
334			
335			
336			
337			
338			
339			

Table 3-9. Calibration Constant Descriptions

Number	Description	Range or Default	Related Adjustment
340			
341			
342			
343			
344			
345			
346			
347			
348			
349			
350			
351	ADC 5V Range +OFF	-5000 to +5000	ADC Adjustment
352	ADC 15V Range +OFF	-5000 to +5000	ADC Adjustment
353	ADC 5V Range +GAIN	-1950 to +1950	ADC Adjustment
354	ADC 15V Range +GAIN	-750 to +750	ADC Adjustment
355	ADC 5V Range -OFF	-5000 to +5000	ADC Adjustment
356	ADC 15V Range -OFF	-5000 to +5000	ADC Adjustment
357	ADC 5V Range -GAIN	-750 to +750	ADC Adjustment
358	ADC 15V Range -GAIN	-1750 to +1950	ADC Adjustment
359			
360			
361			
362			
363			
364			
365			
366			
367	PwrMtr Gain; Lo Band	0	
368	PwrMtr Gain; Hi Band	0	
369	Pwr Mtr Offset	0	
370			
371			
372			
373	YTM Dly Term C Hrm 1	50	
374	YTM Dly Term C Hrm 2	30	
375	YTM Dly Term C Hrm 3	30	
376	YTM Dly Term C Hrm 4	0	
377	YTM Dly Term C Hrm 5	0	
378	YTM Dly Term C Hrm 6	0	
379	YTM Dly Term C Hrm 7	0	
380			
381			
382	YTM Bx Dly Term C 1	0	
383	YTM Bx Dly Term C 2	0	
384	YTM Bx Dly Term C 3	40	
385	YTM Bx Dly Term C 4	0	
386	YTM Bx Dly Term C 5	0	

Table 3-9. Calibration Constant Descriptions

Number	Description	Range or Default	Related Adjustment
387	YTM Bx Dly Term C 6	0	
388	YTM Bx Dly Term C 7	0	
389			
390			
391			
392			
393	*Loop Gain: 200.0 MHz	10 to 20	Sampler Assembly
394	*Loop Gain: 200.5 MHz	10 to 20	Sampler Assembly
395	*Loop Gain: 201.0 MHz	10 to 20	Sampler Assembly
396	*Loop Gain: 201.5 MHz	10 to 20	Sampler Assembly
397	*Loop Gain: 202.0 MHz	10 to 20	Sampler Assembly
398	*Loop Gain: 202.5 MHz	10 to 20	Sampler Assembly
399	*Loop Gain: 203.0 MHz	10 to 20	Sampler Assembly
400	*Loop Gain: 203.5 MHz	10 to 20	Sampler Assembly
401	*Loop Gain: 204.0 MHz	10 to 20	Sampler Assembly
402	*Loop Gain: 204.5 MHz	10 to 20	Sampler Assembly
403	*Loop Gain: 205.0 MHz	10 to 20	Sampler Assembly
404	*Loop Gain: 205.5 MHz	10 to 20	Sampler Assembly
405	*Loop Gain: 206.0 MHz	10 to 20	Sampler Assembly
406	*Loop Gain: 206.5 MHz	10 to 20	Sampler Assembly
407	*Loop Gain: 207.0 MHz	10 to 20	Sampler Assembly
408	*Loop Gain: 207.5 MHz	10 to 20	Sampler Assembly
409	*Loop Gain: 208.0 MHz	10 to 20	Sampler Assembly
410	*Loop Gain: 208.5 MHz	10 to 20	Sampler Assembly
411	*Loop Gain: 209.0 MHz	10 to 20	Sampler Assembly
412	*Loop Gain: 209.5 MHz	10 to 20	Sampler Assembly
413	*Loop Gain: 210.0 MHz	10 to 20	Sampler Assembly
414	*Loop Gain: 210.5 MHz	10 to 20	Sampler Assembly
415	*Loop Gain: 211.0 MHz	10 to 20	Sampler Assembly
416	*Loop Gain: 211.5 MHz	12 to 24	Sampler Assembly
417	*Loop Gain: 212.0 MHz	13 to 26	Sampler Assembly
418	*Loop Gain: 212.5 MHz	14 to 28	Sampler Assembly
419	*Loop Gain: 213.0 MHz	14 to 28	Sampler Assembly
420	*Loop Gain: 213.5 MHz	15 to 30	Sampler Assembly
421	*Loop Gain: 214.0 MHz	16 to 32	Sampler Assembly
422	*Loop Gain: 214.5 MHz	17 to 34	Sampler Assembly
423	*Loop Gain: 215.0 MHz	18 to 36	Sampler Assembly
424	*Loop Gain: 215.5 MHz	18 to 36	Sampler Assembly
425	*Loop Gain: 216.0 MHz	19 to 38	Sampler Assembly
426	*Loop Gain: 216.5 MHz	20 to 40	Sampler Assembly
427	*Loop Gain: 217.0 MHz	22 to 44	Sampler Assembly
428	*Loop Gain: 217.5 MHz	23 to 46	Sampler Assembly
429	*Loop Gain: 218.0 MHz	24 to 48	Sampler Assembly
430	*Loop Gain: 218.5 MHz	28 to 56	Sampler Assembly
431	*Loop Gain: 219.0 MHz	30 to 60	Sampler Assembly
432	*Loop Gain: 219.5 MHz	32 to 64	Sampler Assembly
433	*Loop Gain: 220.0 MHz	32 to 64	Sampler Assembly

Table 3-9. Calibration Constant Descriptions

Number	Description	Range or Default	Related Adjustment
434			
435			
436			
437			
438			
439			
440			
441	Phuoc Magic Enable	0	
442	*SweepTime Range 0	3750 to 6250	Sweep Ramp
443	*SweepTime Range 1	19655 to 32755	Sweep Ramp
444	*SweepTime Range 2	9360 to 15600	Sweep Ramp
445	After Kicks Band 1	0	
446	After Kicks Band 2	0	
447	After Kicks Band 3	0	
448	After Kicks Band 4	0	
449	After Kicks Band 5	0	
450	After Kicks Band 6	0	
451	After Kicks Band 7	0	
452			
453			
454			
455			
456			
457			
458			
459			
460	Debugs	0	
461	Serial Numb Prefix	See footnote 1	
462	Special Options	See footnote 1	
463	Hardware Config	See footnote 1	
464			
465			
466			
467			
468			
469			
470			
471			
472			
473	Power Spec Band 0	See footnote 2	
474	Power Spec Band 1	See footnote 2	
475	Power Spec Band 2	See footnote 2	
476	Power Spec Band 3	See footnote 2	
477	Power Spec Band 4	See footnote 2	
478	Power Spec Band 5	See footnote 2	
479	Power Spec Band 6	See footnote 2	

Table 3-9. Calibration Constant Descriptions

Number	Description	Range or Default	Related Adjustment
480	Power Spec Band 7	See footnote 2	
481			
482			
483			
484			
485			
486			
487	Max Sweep Rate	300	
488	Max Sweep Rate 8516	100	
489			
490			
491			
492			
493	A1 Revision	Indicates assembly revision affecting firmware	
494	A2 Revision	Indicates assembly revision affecting firmware	
495	A3 Revision	Indicates assembly revision affecting firmware	
496	A4 Revision	Indicates assembly revision affecting firmware	
497	A5 Revision	Indicates assembly revision affecting firmware	
498	A6 Revision	Indicates assembly revision affecting firmware	
499	A7 Revision	Indicates assembly revision affecting firmware	
500	A8 Revision	Indicates assembly revision affecting firmware	
501	A9 Revision	Indicates assembly revision affecting firmware	
502	A10 Revision	Indicates assembly revision affecting firmware	
503	A11 Revision	Indicates assembly revision affecting firmware	
504	A12 Revision	Indicates assembly revision affecting firmware	
505	A13 Revision	Indicates assembly revision affecting firmware	
506	A14 Revision	Indicates assembly revision affecting firmware	
507	A15 Revision	Indicates assembly revision affecting firmware	
508	A16 Revision	Indicates assembly revision affecting firmware	
509	A17 Revision	Indicates assembly revision affecting firmware	

Table 3-9. Calibration Constant Descriptions

Number	Description	Range or Default	Related Adjustment
510	A18 Revision	Indicates assembly revision affecting firmware	
511	A19 Revision	Indicates assembly revision affecting firmware	
512	A20 Revision	Indicates assembly revision affecting firmware	
513	A21 Revision	Indicates assembly revision affecting firmware	
514	A22 Revision	Indicates assembly revision affecting firmware	
515	A23 Revision	Indicates assembly revision affecting firmware	
516			
517			
518			
519			
520			
521			
522			
523			
524			
525	Hibernation Time	9	
526	Bandcross Time 1	42	
527	Bandcross Time 2	32	
528	Bandcross Time 3	28	
529	Bandcross Time 4	50	
530	Bandcross Time 5	28	
531	Bandcross Time 6	20	
532	Bandcross Time 7	20	
533			
534			
535			
536			
537			
538			
539			
540			
541			
542			
543			
544			
545			
546			
547			
548			
549			

Table 3-9. Calibration Constant Descriptions

Number	Description	Range or Default	Related Adjustment
550			
551			
552			
553			
554	Display FIFO Time	245	
555			
556			
557			
558			
559			
560			
601			
602			
603			
604			
605			
606			
607			
608			
609			
610			
611			
612			
613			
614			
615			
616			
617			
608			
609			
620			
621			
622			
623			
624			
625			
626			
627			
628			
629			
630			
631			
632			
633			
634			
635			

Table 3-9. Calibration Constant Descriptions

Number	Description	Range or Default	Related Adjustment
636			
637			
638			
639			
640			
641			
642			
643			
644			
645			
646			
647			
648			
649			
650			
651			
652			
653			
654			
655			
666			
667			
668			
669			
670			
671			
672			
673			
674			
675			
676			
677			
678			
679			
680			
681			
682			
683			
684			
685			
686			
687			
688			
689			
670			
671			

Table 3-9. Calibration Constant Descriptions

Number	Description	Range or Default	Related Adjustment
672 673 674 675 676 677 678 679 680 681 682 683 684 685 686 687 688 689 690	Display FSCC Time	0	
<p>1 Specific to the synthesizer's hardware configuration. The calibration constant value is set at the factory.</p> <p>2 Specified maximum leveled power for the band (for example, 7 dBm = 700, 10 dBm = 1000):</p>			

4 AUTOMATED TESTS

4. Automated Tests

INTRODUCTION

This chapter contains information on how to load and run the automated performance tests, automated adjustments, front panel emulation program, and calibration constants utility (see below). These tests do require operator interaction.

This software requires that the synthesizer be set to the TMSL Programming Language. This can be set by the rear panel switch or by the front panel. Refer to the "INSTALLATION" chapter of the *User's Handbook* for further information.

After using the software, return the synthesizer to its original setting.

TOPIC	Page
Setting Up the System	2
Installing the Software	3
Running the Software	5
Reporting Software Bugs	6
Automated Performance Tests	
1. Step Attenuator Flatness Test	7
2. Power Flatness and Accuracy Test	9
Automated Adjustments	
1. Step Attenuator Flatness Adjustment	11
2. YO Delay Adjustment	13
3. ADC Adjustment	13
4. Power Flatness Adjustment	14
Utilities	
1. Front Panel Emulation	17
2. Calibration Constants	20
3. Self-Test	20
Software Support Request	21

SETTING UP THE SYSTEM

Hardware Requirements

The automated tests require an HP 9000 series 200/300 desktop computer with at least 4 megabytes of RAM, a disk drive, and an HP-IB interface. Software is provided on 3.5 inch disks, formatted double-sided, and are usable in double-sided disk drives only. If you require single-sided disks, see "Double-to Single-Sided Disk Conversion." Any required measurement instruments are listed in each test procedure.

Operating System Requirements

The performance test software requires BASIC version 5.1 and the following binaries.

Table 4-1. Required Binaries

Language Extensions	Drivers
CLOCK	CRTA or CRTB (depends on CRT)
COMPLEX	CS80 or DISC (depends on disk)
CRTX	HFS
EDIT	HPIB
ERR	SRM
GRAPH	
GRAPHX	
IO	
KBD	
MAT	
MS	
PDEV	
TRANS	
XREF	

Refer to the BASIC user's documentation for instructions on loading the operating system and binaries.

INSTALLING THE SOFTWARE

Disk Files

The automated tests are provided on two double-sided disks. Both disks are required for the software to operate properly.

Make Working Copies

Before doing anything else, make working copies of the two master disks! When making working copies, do not split up the files contained on Disk 1. These must all reside on the same mass storage medium. The files on Disk 2 must also reside together.

Note



When copying onto another 3.5 inch, double-sided disk, you must specify the interleave factor and also the format to be used during initialization of your blank disk. The required interleave factor is 2 and the required format is 3 (1024 bytes/sector).

Type: INITIALIZE "Address of drive containing blank floppy",2,3

The master disks are shipped from the factory write-protected and cannot be written to or initialized in this mode. We recommend you maintain these master disks in write-protect mode. During execution of some tests, the program reads from and writes to one of the disks, use a working copy that is not write-protected when you run the software.

Installing Program to a Hard Disk

We recommend that you run the software from a hard disk. It is possible to operate it from a single or dual floppy disk drive, however speed will be sacrificed.

To install the program onto your hard disk, create a directory that will contain the program and its associated files. (Refer to the BASIC user's documentation for instructions on creating directories.) After you create the directory, run the install program below to load all of the files onto your hard disk.

Insert Disk 2.

In the directory created,

Type: "INST_OPV" and press **(RETURN)**.

Press: **(RUN)** and follow the prompts.

Your hard disk is now set up to run the automated tests.

Operating From a Floppy Disk

When you run the software from a floppy disk drive, first load the program from Disk 1 when instructed to do so in "Loading the Performance Test Program." Then insert Disk 2 and leave it in the disk drive while the program runs. Failure to do so will cause the program to crash.

Double-to Single-Sided Disk Conversion

If you require a single-sided disk, the master disks can be converted to single-sided format using a double-sided disk drive. Use the following procedure to make the conversion. Press **(RETURN)** after each command. For information on formatting a single-sided disk on a double-sided drive, refer to the BASIC user's documentation.

1. Insert Disk 1 into the disk drive.
Set the default mass storage to the drive containing the disk.
Type: LOAD "OPV_8360"
DEL label_1, 32000
2. Remove the disk and insert a single-sided, formatted disk into the same drive (Disk 1A).
Type: STORE "8360_1A"
3. Remove the disk and insert the original disk.
Type: LOAD "OPV_8360"
DEL label_2, 32000
DEL 1, label_1
4. Remove the disk and insert another single-sided, formatted disk into the same drive (Disk 1B).
Type: STORE "8360_1B"
5. Remove the disk and insert the original disk.
Type: LOAD "OPV_8360"
DEL 1,label_2
6. Remove the disk and insert another single-sided, formatted disk into the same drive (Disk 1C).
Type: STORE "8360_1C"
7. Remove the disk and insert the original Disk 2.
Type: LOAD "COPY_DISK2"
Press: **(RUN)**

RUNNING THE SOFTWARE

Caution



This software uses RAM memory volumes for fast access of data files. These volumes may also be used by other programs and could contain data that will be erased by this program. Make sure that the computer you are using does not have important data in any memory volumes before running this software.

Configuration Limitations

The computer containing the software must be the *only* controller on the bus. If more than one controller is present, the software does not run properly.

Loading the Performance Test Program

1. Make sure the software has been copied into a directory (if running from a hard disk) or copied to a work disk (if running from a floppy disk).
2. Set the default mass storage to the directory or floppy disk that contains the test software. Use the BASIC MSI command. See the BASIC Language Reference for more information on setting the default mass storage.
3. Load the test software.

NOTE: CAPS LOCK ON or OFF cannot be changed while the program is running. Set the keyboard before you load the software.

Insert Disk 1 in your default drive, or from your hard-drive directory, perform the following: (for single-sided formatted disks, see "Loading Single-Sided Disks")

Type: LOAD "OPV_8360"

Press (RETURN).

4. When the drive light turns off, (if running off of a floppy disk, insert Disk 2 into the default drive) press (RUN) to start the test program.
5. The program displays a menu with the available model numbers. Using the arrow keys, select the correct model to be tested. Press (RETURN).
6. The program asks for the installed options and the serial number of the unit under test. Enter the appropriate information.

7. A menu of the available tests is displayed. Using the arrow keys, select the appropriate test. Press **(RETURN)**.

Note



Refer to the following pages for a detailed description and specific operating information (if any) for a specific test.

8. Follow the prompts in the individual tests for connection instructions and other relevant test information. When the test finishes, you are returned to the test menu.
9. Either select another test to run or select the **[QUIT]** softkey to exit the program.

Loading Single-Sided Formatted Disks

Use the following steps to load single-sided disks. Press **(RETURN)** after each command.

1. Insert Disk 1A into your default drive.
Type: LOAD "8360_1A"
2. Remove Disk 1A and insert Disk 1B.
Type: LOADSUB ALL FROM "8360_1B"
3. Remove Disk 1B and insert Disk 1C.
Type: LOADSUB ALL FROM "8360_1C"
4. Remove Disk 1C and insert Disk 2.
Press **(RUN)**.

REPORTING SOFTWARE BUGS

If a test does not run correctly, re-run the test. If the test fails to run properly again, fill out the "Software Support Request" at the end of this chapter and return it to your local HP sales office.

AUTOMATED PERFORMANCE TESTS

1. STEP ATTENUATOR FLATNESS TEST

Description

Using the measuring receiver in the tuned receiver mode, you are able to measure extremely low power levels. You measure the power over the frequency range of the instrument. The spectrum analyzer down-converts the frequency to the range required by the measuring receiver. The spectrum analyzer must have low conversion loss and low noise so that it will not adversely affect the measurements being made.

Two tests are provided; a full performance test and a limited performance test. The full performance test takes approximately 4 hours for 20 GHz units and 8 hours for 40 GHz units. The limited performance test, tests approximately half as many points as the full test and is therefore significantly faster.

The following test equipment is required for this performance test. No substitutions are allowed.

Test Equipment Required

Instrument	HP Model Number
10 dB Attenuator	8490D
20 dB Attenuator	8493C
Waveguide to Coax Adapter (22 GHz to 26.5 GHz)	K281C
Waveguide to Coax Adapter (26.5 GHz to 40 GHz)	R281A
Isolator	R365A
Mixer*	11970A
Mixer**	11970K
Measuring Receiver	8902A
Microwave Spectrum Analyzer (With the following plug-ins)	
Frequency Reference	70310A
IF Section	70902A
RF Section	70908A
External Mixer Interface	70907A
Local Oscillator	70900A

*#2 in Figure 4-1.

**#1 in Figure 4-1.

Procedure

Connect the equipment as shown in figure 4-1. Preset all instruments and let them warm up for at least one hour.

Note



The spectrum analyzer's external mixer interface must be set up at input 1 and the RF section at input 2.

Select the full or limited step attenuator flatness test and follow the prompts on the display.

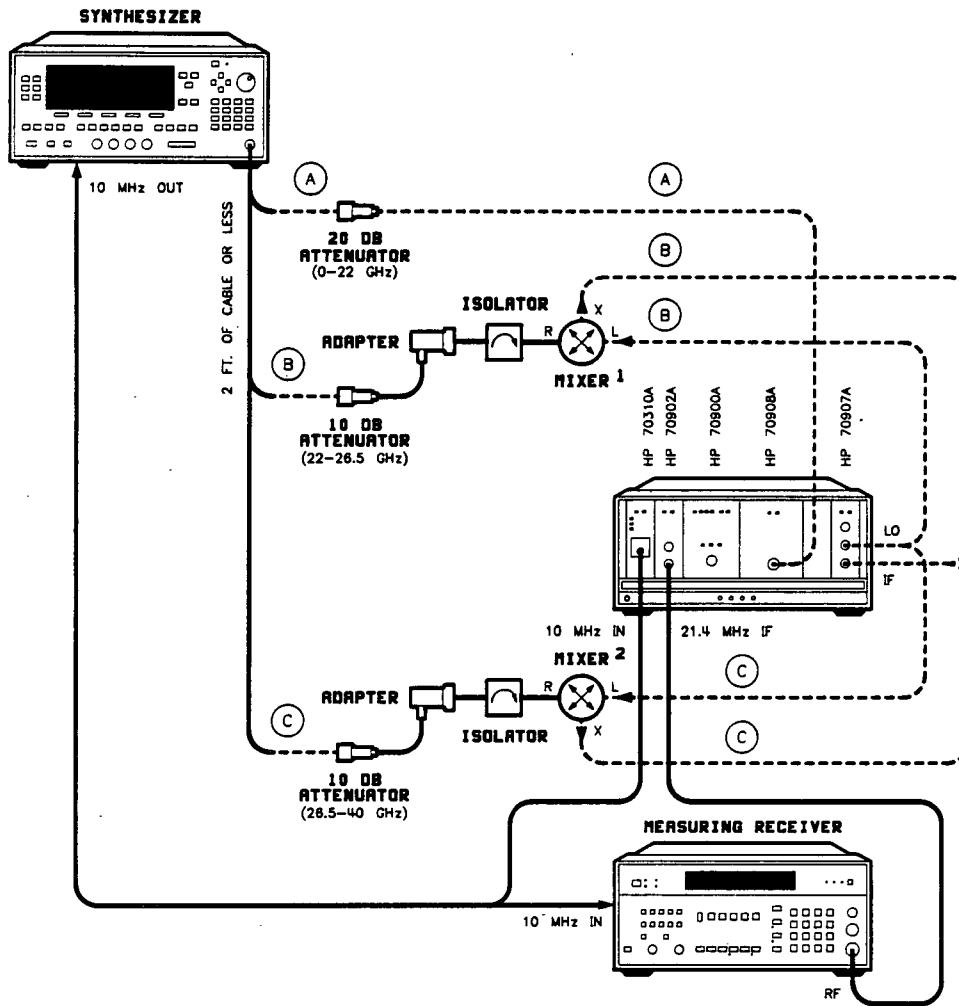

Figure 4-1. Step Attenuator Flatness Setup

2. POWER FLATNESS AND ACCURACY TEST

Description

This test is provided for instruments without front panels. The test is provided as a softkey on the front panel, but cannot be run by the front panel emulation program because of its interaction with the power meter.

This test uses the user flatness correction array to measure power flatness at the RF output. The power is measured every 10 MHz in low band and every 100 MHz in high and millimeter bands. The calibration constants are adjusted to achieve a flat output.

The calibration factors for the power sensor must be added to the program before the test is run.

The following test equipment is required for this test. No substitutions are allowed. (The test setup is given in the software.)

Test Equipment Required

Instrument	HP Model Number
Power Meter	438A
Power Sensor (100 kHz to 4.2 GHz)	8482A
Power Sensor (50 MHz to 26.5 GHz)	8485A
Power Sensor (50 MHz to 50 GHz)*	8487A
10 dB Attenuator (DC to 26.5 GHz)	8493C

*For 40 GHz synthesizers only.

Procedure

Select the power flatness and accuracy test and enter your power sensor data by following the steps below.

Note



If the power sensor data was added previously, and is still current, skip the following steps and run the test.

1. Select the **[HELP]** softkey to access the power sensor configuration and calibration menus.
2. Select power meter configuration.
3. Select the sensor to edit.
4. Enter the power sensor configuration data (follow the prompts on the display).

Note



Do not edit the "Sensor ID". The names set at the factory must remain unchanged for the program to run properly. The factory recommended "Zero Hr" is 1.00 and the "Cal Hr" is 24.00. Use the left and right arrows to move the cursor within a field and the up and down arrows to increment or decrement the value. **RETURN** selects the field.

5. When all changes have been made, select save power meter configuration.
6. Next select power meter calibration factors to add the power sensor calibration factors to the program.
7. Select current to change the active power sensor to the one for which you would like to enter the data.
8. Select edit header, and enter the serial number of the power sensor.
9. Select edit calibration factors.
10. Enter the calibration factors from your power sensor (follow the prompts on the display).
10. When all of the calibration factors have been added, select store calibration factors to store the calibration factors for future use.
12. Exit the power meter calibration.
13. Run the power flatness and accuracy test.

AUTOMATED ADJUSTMENTS

1. STEP ATTENUATOR FLATNESS ADJUSTMENT

Before doing any adjustment, enter the password for access to the adjustment calibration constants. Use the front panel or the front panel emulation program provided with this software.

See "Calibration Constants" in the *Calibration* manual for information on enabling the calibration constants with the password.

Description

Using the measuring receiver in the tuned receiver mode, you are able to measure extremely low power levels. You measure the power over the frequency range of the instrument. The spectrum analyzer down-converts the frequency to the range required by the measuring receiver. The spectrum analyzer must have low conversion loss and low noise so that it will not adversely affect the measurements being made.

The frequency is measured every 10 MHz in low band and every 100 MHz in high and millimeter bands. The points are adjusted for maximum flatness and stored in the digital ALC array.

The following test equipment is required for this adjustment. No substitutions are allowed.

Test Equipment Required

Instrument	HP Model Number
10 dB Attenuator	8490D
20 dB Attenuator	8493C
Waveguide to Coax Adapter (22 GHz to 26.5 GHz)	K281C
Waveguide to Coax Adapter (26.5 GHz to 40 GHz)	R281A
Isolator	R365A
Mixer*	11970A
Mixer**	11970K
Measuring Receiver	8902A
Microwave Spectrum Analyzer (With the following plug-ins)	
Frequency Reference	70310A
IF Section	70902A
RF Section	70908A
External Mixer Interface	70907A
Local Oscillator	70900A

*#2 in Figure 4-2.

**#1 in Figure 4-2.

Procedure

Connect the equipment as shown in figure 4-2. Preset all instruments and let them warm up for at least one hour.

Note



The spectrum analyzer's external mixer interface must be set up at input 1 and the RF section at input 2.

Select the step attenuator flatness adjustment and follow the prompts on the display.

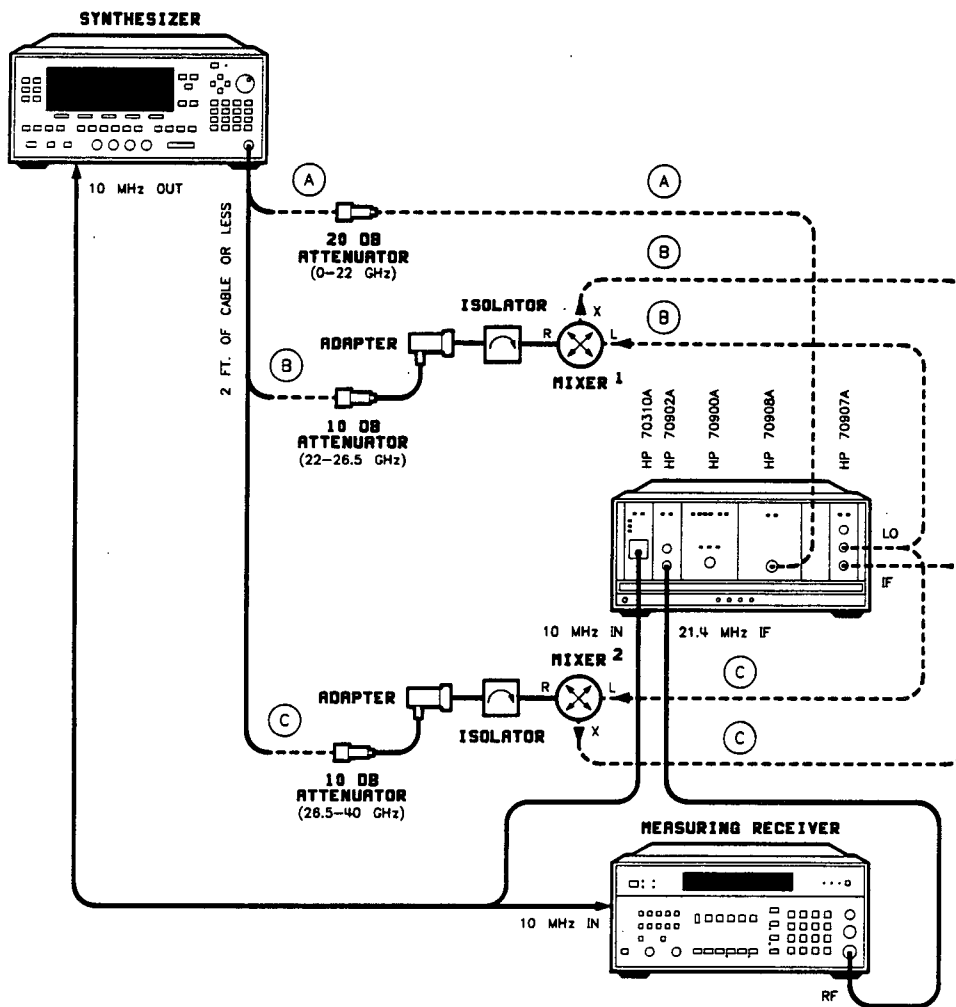

Figure 4-2. Step Attenuator Flatness Setup

2. YO DELAY ADJUSTMENT

Description

This adjustment uses the internal counter to measure swept frequency accuracy. YO Delay affects the swept frequency accuracy at fast sweep times (less than 100 ms). This procedure adjusts the calibration constants for the YIG Oscillator to achieve consistent swept frequency accuracy over the entire operating range of the instrument.

Select the YO delay adjustment and follow the prompts on the display.

No test equipment is required.

3. ADC ADJUSTMENT

Description

This adjustment uses an external digital voltmeter (DVM) to measure VCOMP on the YO Driver assembly and compares the reading to the ADC measurement. The ADC calibration constants are adjusted so that the DVM and ADC measurements are the same. The procedure is repeated for each voltage range (both plus and minus supplies).

Select the ADC adjustment and follow the prompts on the display.

The following test equipment is required for this adjustment. No substitutions are allowed. (The test setup is given in the software.)

Test Equipment Required

Instrument	HP Model Number
Digital Voltmeter	3457A

4. POWER FLATNESS ADJUSTMENT

Description

This test is provided for instruments without front panels. The test is provided as a softkey on the front panel, but cannot be run by the front panel emulation program because of its interaction with the power meter.

This adjustment zeros the digital ALC array and measures the power from the RF output. The power is measured every 10 MHz in low band and every 100 MHz in high and millimeter band. The calibration constants are adjusted to achieve a flat output.

The calibration factors for the power sensor must be added to the program.

The following test equipment is required for this adjustment. No substitutions are allowed. (The test setup is given in the software.)

Test Equipment Required

Instrument	HP Model Number
Power Meter	438A
Power Sensor (100 kHz to 4.2 GHz)	8482A
Power Sensor (50 MHz to 26.5 GHz)	8485A
Power Sensor (50 MHz to 50 GHz) *	8487A
10 dB Attenuator (DC to 26.5 GHz)	8493C

*For 40 GHz synthesizers only.

Procedure

Select the power flatness adjustment and enter your power sensor data by following the steps below.

Note



If the power sensor data was added previously, and is still current, skip the following steps and run the test.

1. Select the **[HELP]** softkey to access the power sensor configuration and calibration menus.
2. Select power meter configuration.
3. Select the sensor to edit.
4. Enter the power sensor configuration data (follow the prompts on the display).

Note

Do not edit the "Sensor ID". The names set at the factory must remain unchanged for the program to run properly. The factory recommended "Zero Hr" is 1.00 and the "Cal Hr" is 24.00. Use the left and right arrows to move the cursor within a field and the up and down arrows to increment or decrement the value. **RETURN** selects the field.

5. When all changes have been made, select save power meter configuration.
6. Next select power meter calibration factors to add the power sensor calibration factors to the program.
7. Select current to change the active power sensor to the one for which you would like to enter the data.
8. Select edit header and enter the serial numbers of the power sensor.
9. Select edit calibration factors.
10. Enter the calibration factors from your power sensor (follow the prompts on the display).
11. When all of the calibration factors have been added, select store calibration factors to store the calibration factors for future use.
12. Exit the power meter calibration.
13. Run the power flatness adjustment.

UTILITIES

1. FRONT PANEL EMULATION

Description

This utility simulates an 8360 series instrument front panel keyboard in an instrument with a delete front panel option installed.

Procedure

To access the front panel emulation utility select the front panel emulation program in the test menu.

The front panel emulation program cannot run front panel functions that use a power meter or printer. These functions cause the 8360 series instrument to act as a controller, which conflicts with the computer as the controller on the bus. Use a substitute front panel to run these functions, or use the tests provided with this software.

When using the front panel emulation program, enter the letter directly above the caret (^) to activate the function or key. Note that the keys are case sensitive ("L" means "ALC" and "I" means "LOCAL"). Refer to table 4-2 for a detailed listing of hardkey designations.

For numeric entry, two different terminator keys are combined on one hardkey. The actual terminator depends on the active mode of the synthesizer.

For example: When pulse width is the active entry, (10) (k) enters 10 ms. When frequency span is the active entry, (10) (k) enters 10 kHz.

Softkeys are designated by menukey X, where X is 1 through 5 and corresponds to the five softkey positions below the display. To activate the softkey, press the function key on the keyboard that corresponds to the number X indicated by menukey.

Table 4-2. Synthesizer Hardkey Emulation (1 of 2)

Hardkey	Program Display	To Activate Select
MENU SELECT		
MOD	mod ^	m
ALC	aLc ^	L
MARKER	mrK ^	K
USER CAL	cal ^	c
SERVICE	Srv ^	S
PRIOR	Prior ^	P
SYSTEM		
SAVE	saVe ^	V
RECALL	Rcl ^	R
MENU	meNu ^	N
USER DEFINED		
MENU	menU ^	U
ASSIGN	asgn ^	a
ENTRY		
ENTRY ON/OFF	entry off ^	f
GHz/dB(m)	GHz/dBm ^	G
MHz/usec	MHz/uS ^	M
kHz/msec	kHz/mS ^	k
Hz,sec/ENTER	Hz/ENT ^	H
SWEEP		
SWEEP TIME	Time ^	T
SINGLE	sing ^	I
CONT	cOnt ^	O
MENU	mEnu ^	E

Table 4-2. Synthesizer Hardkey Emulation (2 of 2)

Hardkey	Program Display	To Activate Select
FREQUENCY		
(CW)	cW ^	W
(START)	stArt ^	A
(STOP)	stop ^	o
(CENTER)	Cent ^	C
(SPAN)	span ^	n
(MENU)	menu ^	u
POWER		
(POWER LEVEL)	level ^	v
(FLTNESS ON/OFF)	flAt ^	t
(RF ON/OFF)	on/oFf ^	F
(MENU)	menu ^	e
INSTRUMENT STATE		
(PRESET)	presEt ^	r
(LOCAL)	locAl ^	l

2. CALIBRATION CONSTANTS

Before accessing the calibration constants, enter the password to allow access to the constants. Use the front panel or the front panel emulation program provided with this software.

See "Calibration Constants" in the *Calibration* manual for information on enabling the calibration constants with the password.

Description

Use this utility to print out a list of the calibration constants stored in the instrument, to make a back-up of the calibration constants, and to restore calibration constants from a backed-up file.

Procedure

The calibration constants utility provides a variety of ways to manipulate the calibration constants stored in the instrument.

You may need to perform several steps to reach your final goal. For example, to move the calibration constants from the instrument's working memory to a disk for back-up, you must first move them to the computer memory, and then from computer memory to disk. To store the calibration constants, you may use the hard disk drive, Disk 2 of your working disks, or a separate data disk. When storing data on a new disk, be sure to format the disk before you begin the utility.

Select the calibration constants entry in the test menu and follow the prompts.

3. SELF-TEST

Description

When selected, this utility executes a full self-test of the synthesizer and prints the results on the display or to a printer. You can also execute the self-test through the front panel emulation program.



HEWLETT
PACKARD

INSTRUMENT SYSTEM

Software Support Request

SUBMITTED BY (SYSTEM MANAGER)		PHONE	EXTENSION	DATE	CUSTOMER REFERENCE *
COMPANY NAME		SYSTEM MODEL		SERIAL #	
DEPARTMENT/DIVISION/BUILDING	SOFTWARE PRODUCT INFORMATION	NAME			
ADDRESS		NUMBER			
		REVISION CODE			
CONFIGURATION (Include the minimum hardware, software and firmware on which the problem occurs. This should include applicable options, date code and revision, etc.)					
PROBLEM DESCRIPTION (Include environment, symptom, what you were trying to do, what went wrong, and any other information that might be helpful.)					
DOCUMENTATION (List all the supportive documentation included with this report. You must provide all relevant programs, data lines, data bases, etc. Please label the media.)					
MEDIA	DESCRIPTION				
_____	_____				
_____	_____				
_____	_____				

9320-5327

Return this form to your local HP Sales Office, Attn: Instrument SEDM

HP 8360

High Power Automated Tests

4-21



INSTRUMENT SYSTEM

Software Support Request

SUBMITTED BY (SYSTEM MANAGER)		PHONE	EXTENSION	DATE	CUSTOMER REFERENCE *
COMPANY NAME		SYSTEM MODEL		SERIAL #	
DEPARTMENT/DIVISION/BUILDING	SOFTWARE PRODUCT INFORMATION	NAME			
ADDRESS		NUMBER			
		REVISION CODE			
CONFIGURATION (Include the minimum hardware, software and firmware on which the problem occurs. This should include applicable options, date code and revision, etc.)					
PROBLEM DESCRIPTION (Include environment, symptom, what you were trying to do, what went wrong, and any other information that might be helpful.)					
DOCUMENTATION (List all the supportive documentation included with this report. You must provide all relevant programs, data files, data bases, etc. Please label the media.)					
MEDIA	DESCRIPTION				
_____	_____				
_____	_____				
_____	_____				

9320-5327

Return this form to your local HP Sales Office, Attn: Instrument SEDM

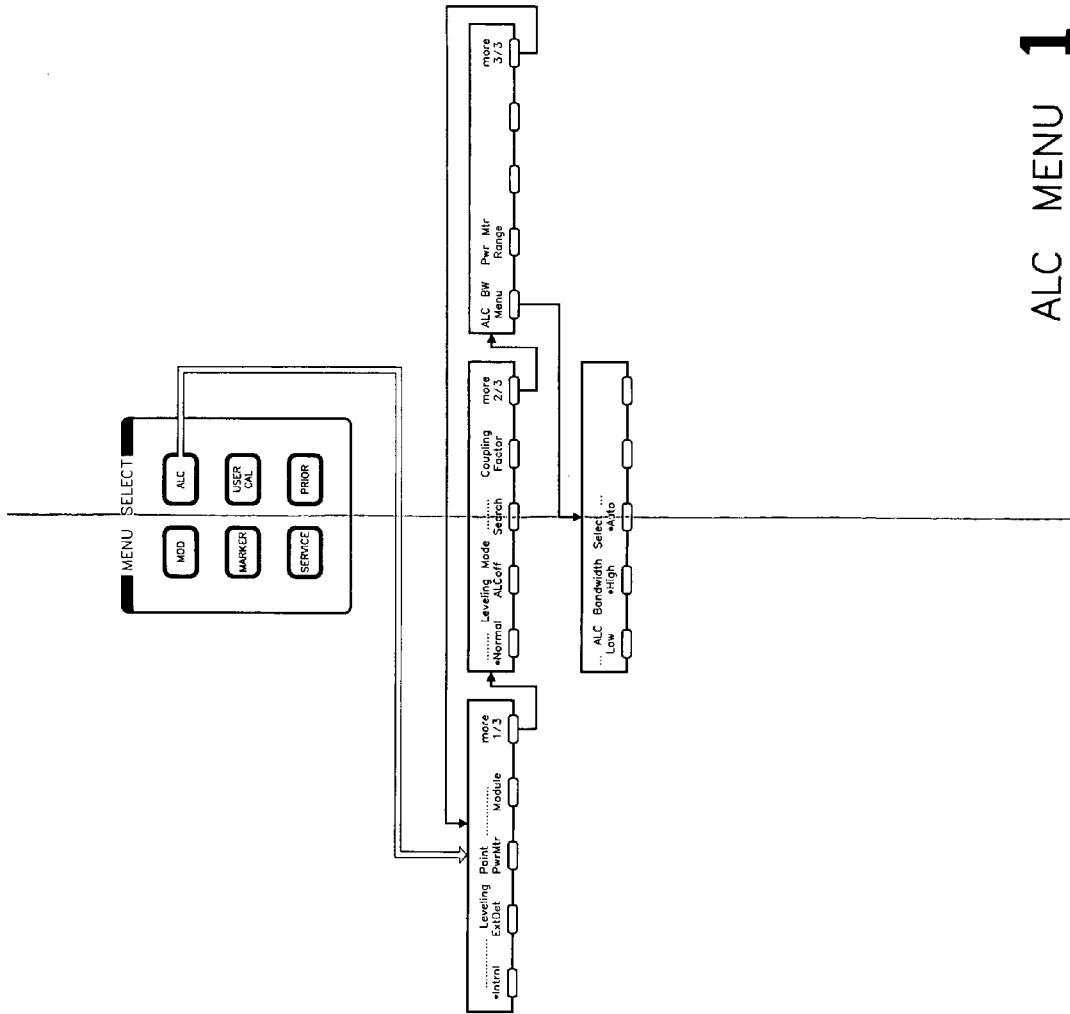

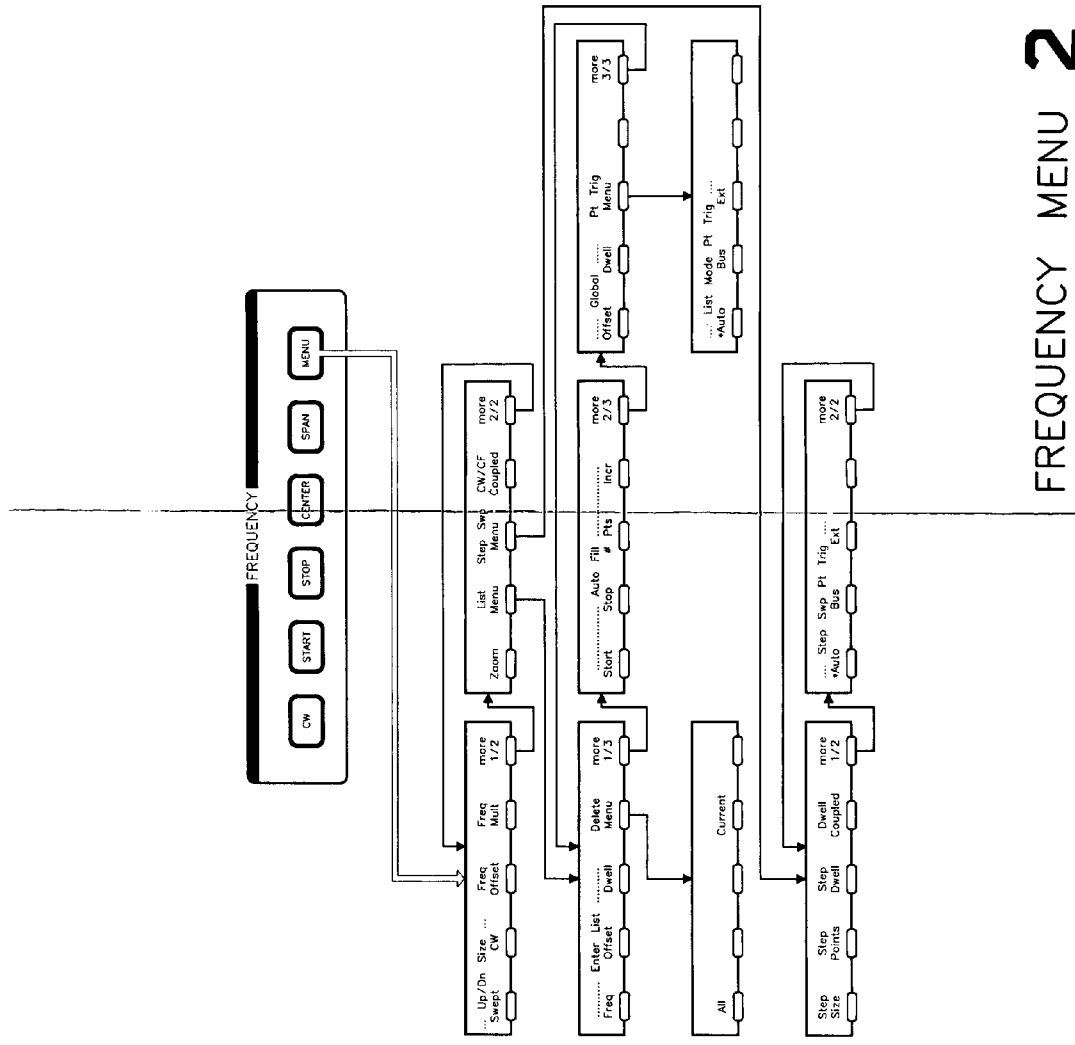

FREQUENCY MENU 2

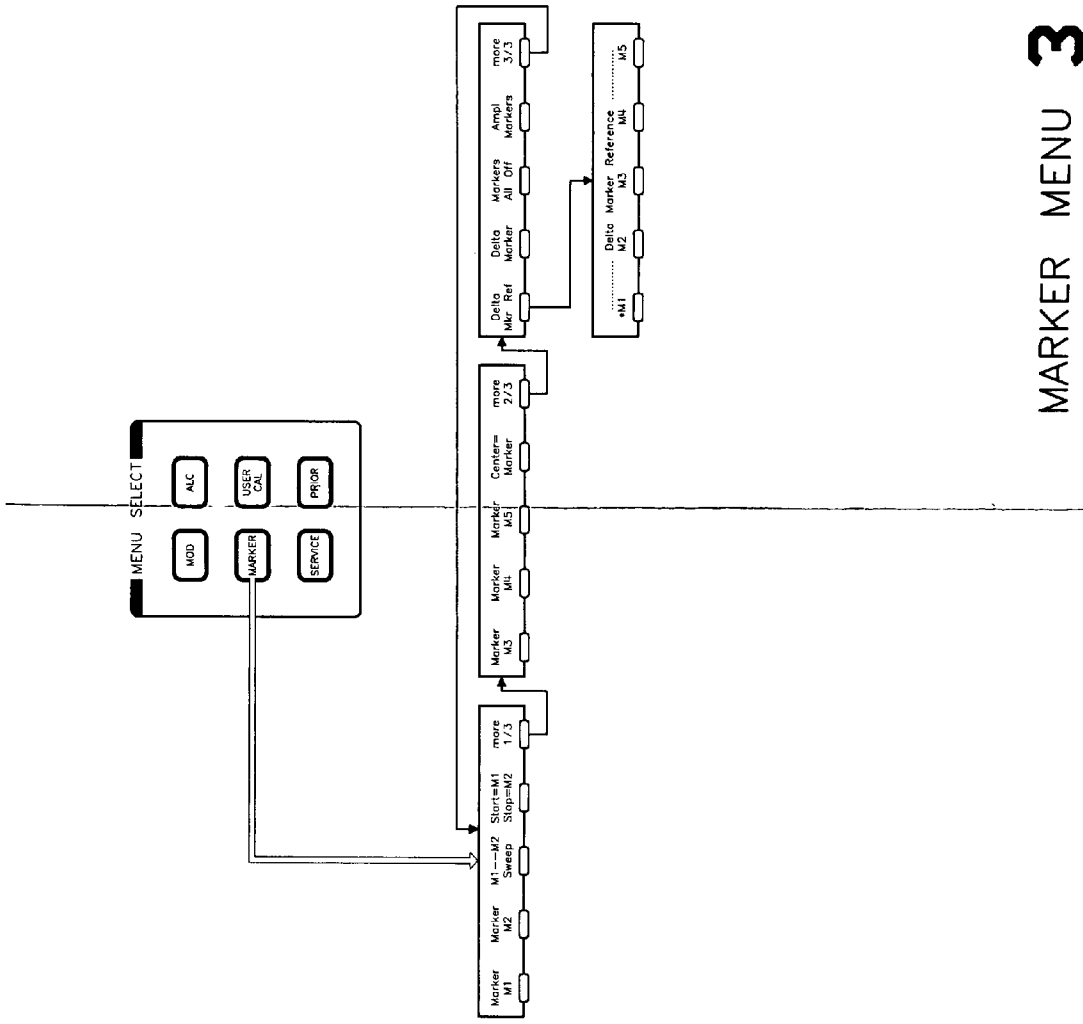

MARKER MENU 3

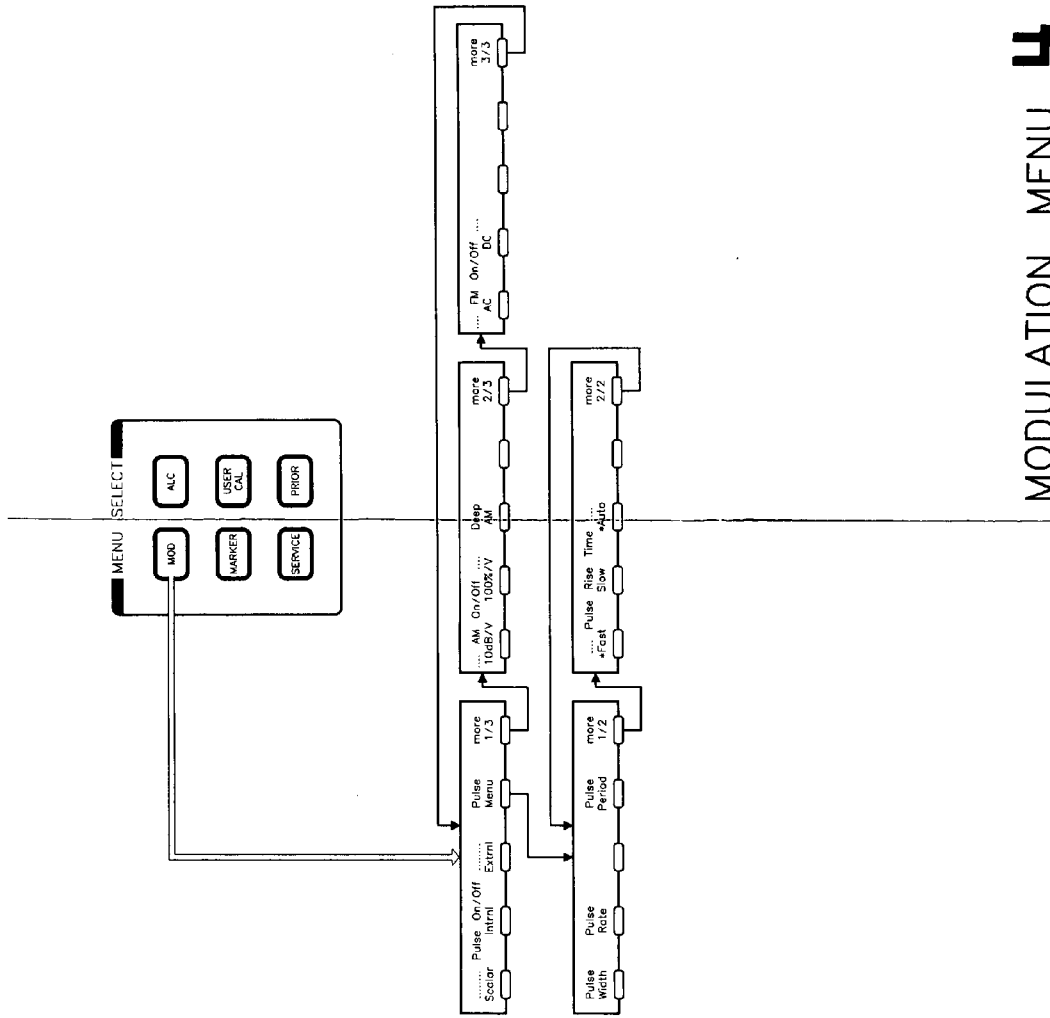

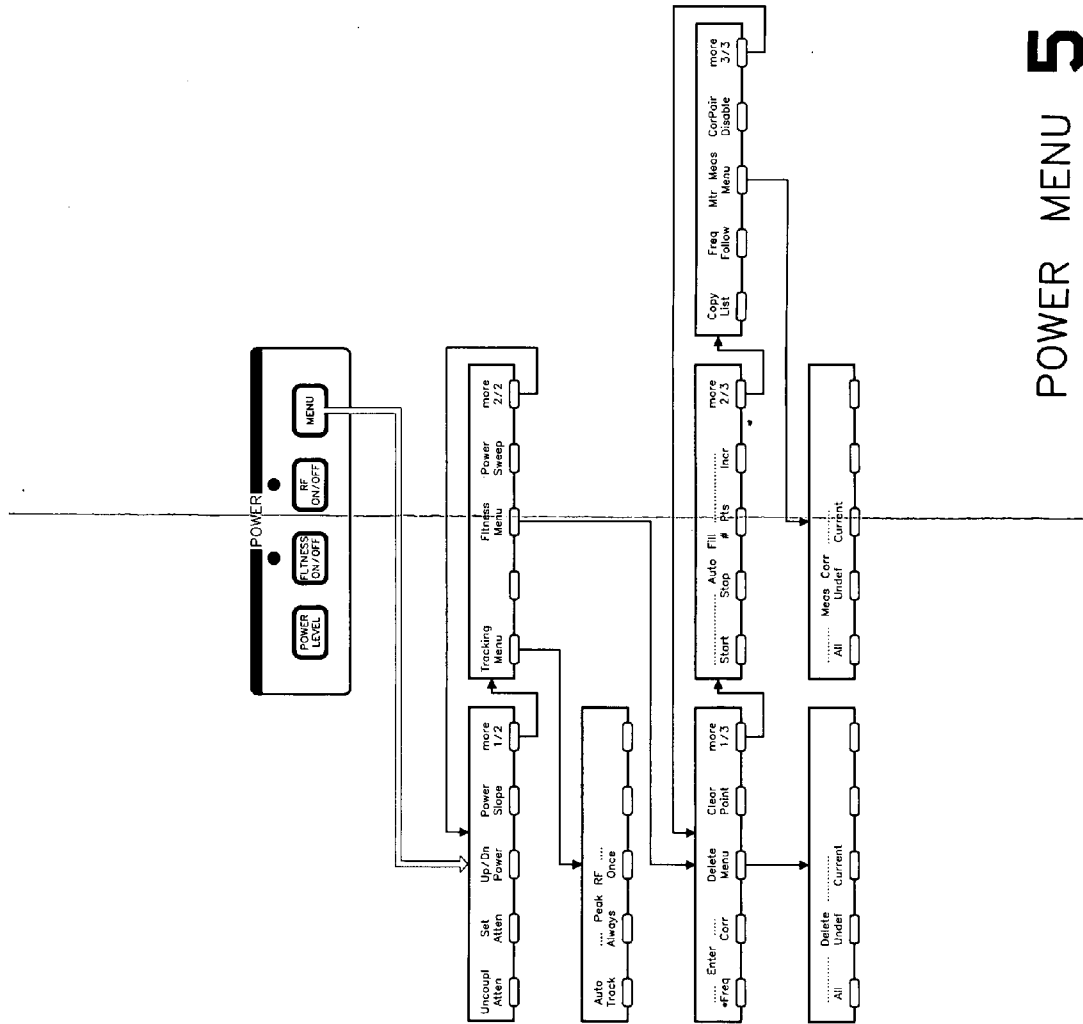

POWER MENU 5

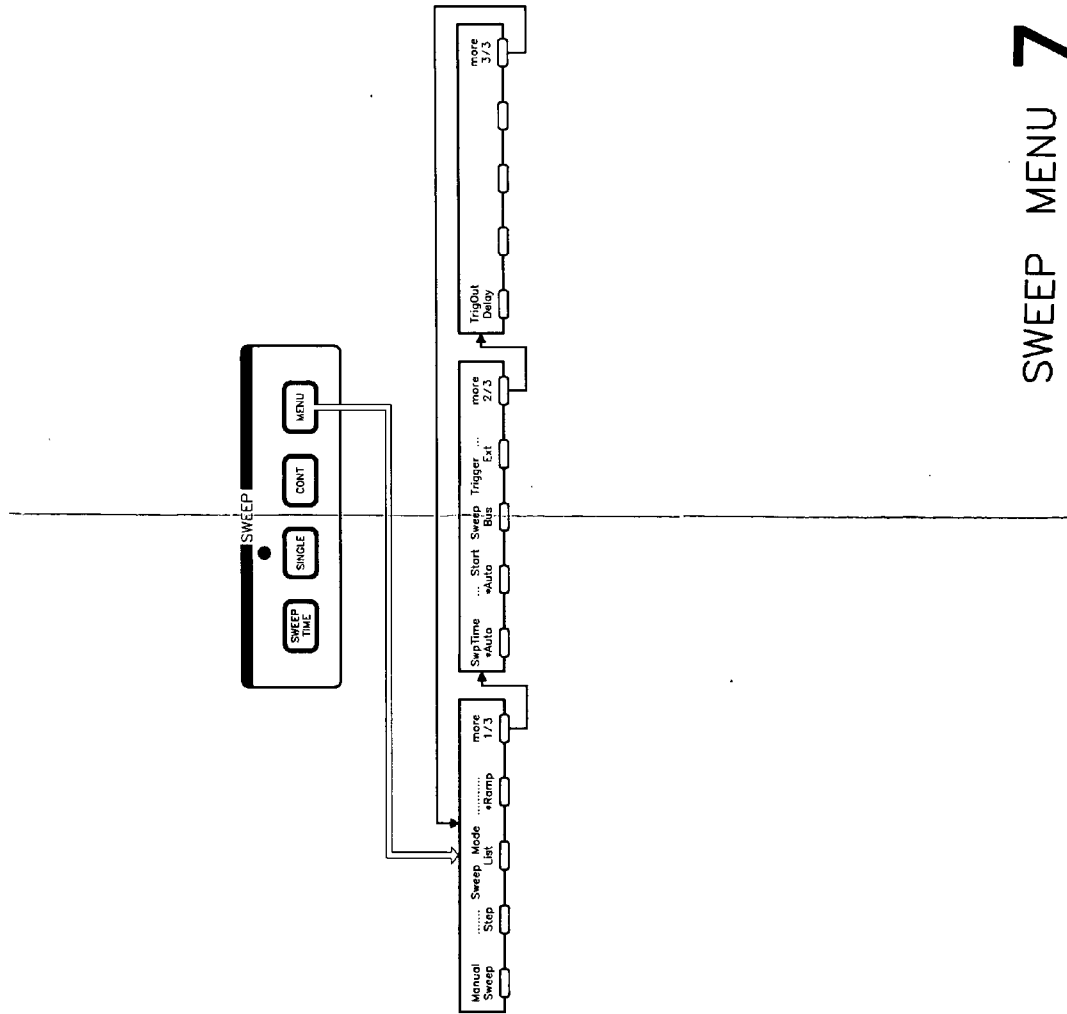

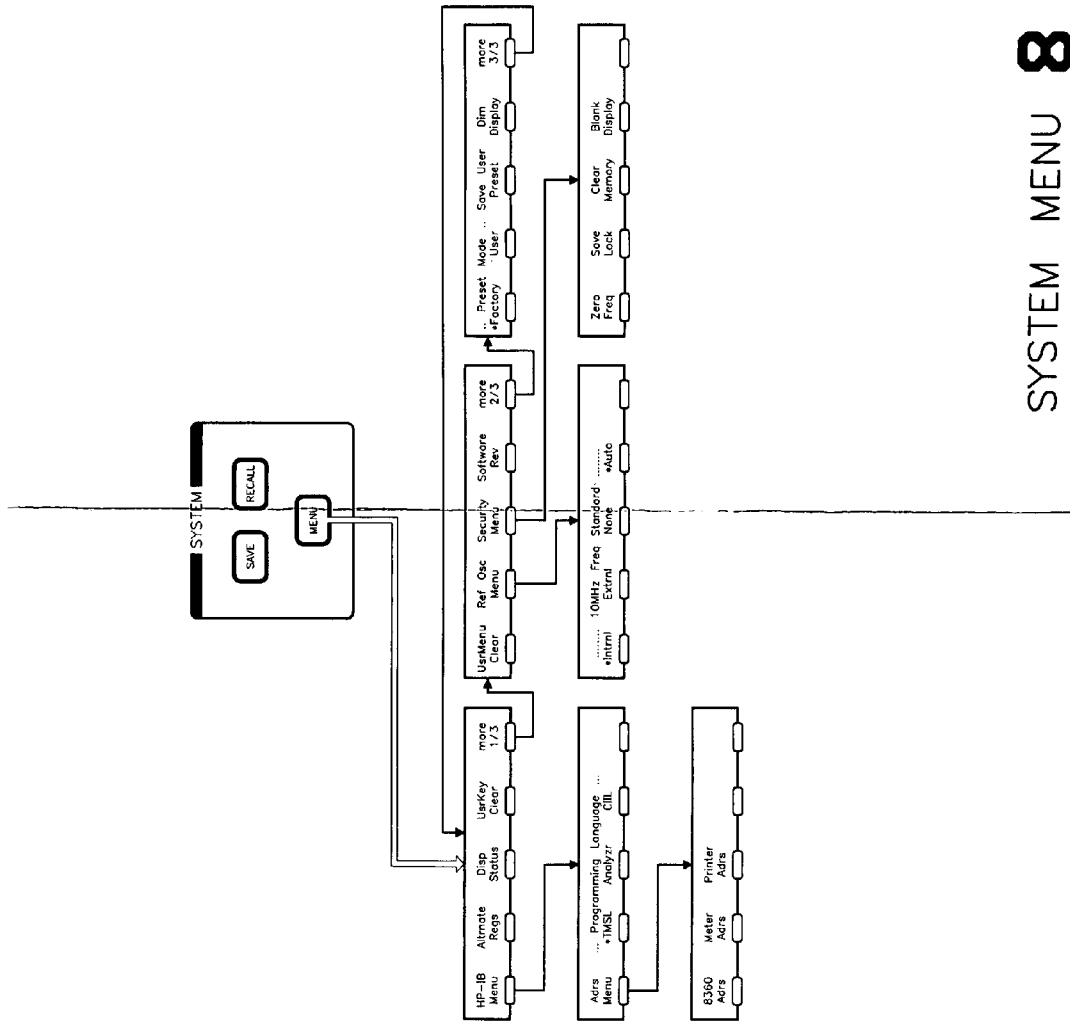

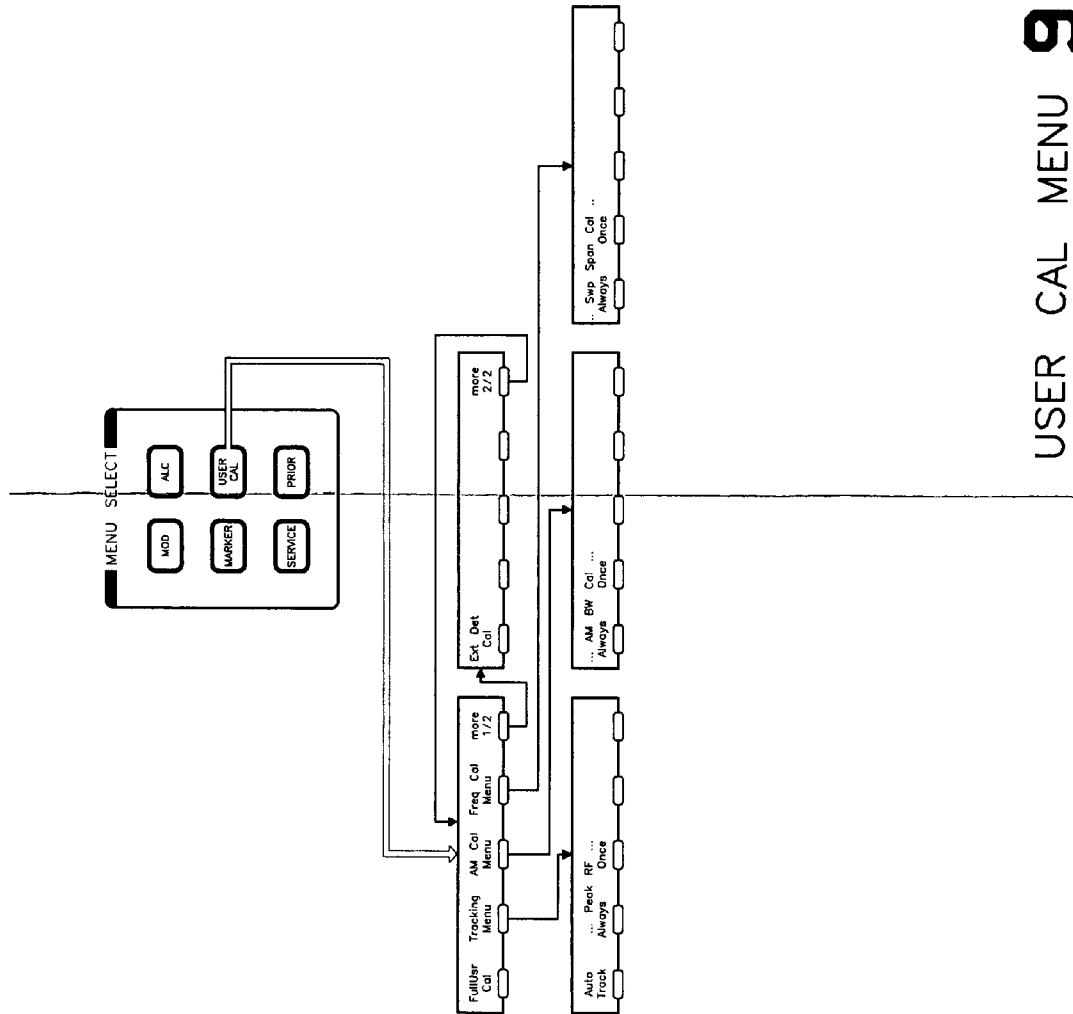

GLOSSARY

GLOSSARY

ADC: Analog-to-Digital Converter.

ALC: Automatic Leveling Control.

API: Analog Phase Interpolator.

EEPROM: Electrically Erasable Programmable Read-Only Memory.

factory preset: The factory-set standard starting configuration of the synthesizer when **PRESET** is pressed.

quadrature: A 90° offset between mixer inputs.

squigg: A distortion in the RF output caused by too much power to the SYTM and characterized by a power dropout in a portion of the trace or a power dropout over a broad frequency range.

SRD: Step Recovery Diode.

SYTM: Switched YIG-Tuned Oscillator.

UVEPROM: Ultraviolet Erasable Programmable Read-Only Memory.

VCO: Voltage Controlled Oscillator

YO: YIG (Yttrium-Iron-Garnate) Oscillator.

INDEX

INDEX

10 MHz standard adjustment. *see* adjustments

A

ADC adjustment. <i>see</i> automated adjustments	
adjustments	3-1
10 MHz standard	3-3
ALC power level accuracy	3-63
AM accuracy	3-71
AM delay	3-75
amplifier detector gain	3-57
amplifier detector offset	3-27
automated. <i>see</i> automated adjustments	
FM gain	3-81
fractional-N VCO	3-7
fractional-N reference and API spurs	3-9
low power SRD bias	3-53
modulator offset and gain	3-59
power flatness	3-69
pulse delay	3-77
sampler assembly	3-15
IF gain	3-17
200 MHz loop gain	3-17
200 MHz loop VCO tune	3-16
sampler match	3-17
VCO fixed trim capacitor selection	3-19
square wave symmetry	3-85
sweep ramp	3-13
SYTM adjustments	3-29
YO driver + 10V reference	3-21
YO driver gain and linearity	3-23
YO loop gain	3-25
aging rate	2-5
ALC power level accuracy adjustment. <i>see</i> adjustments	
AM accuracy adjustment. <i>see</i> adjustments	
AM accuracy performance test. <i>see</i> performance tests	
AM bandwidth performance test. <i>see</i> performance tests	
AM delay adjustment. <i>see</i> adjustments	
AM dynamic range performance test. <i>see</i> performance tests	
amplifier detector gain adjustment. <i>see</i> adjustments	
amplifier detector offset adjustment. <i>see</i> adjustments	
automated adjustments	
ADC	4-13
power flatness	4-14
step attenuator flatness	4-11
YO delay	4-13
automated performance tests	
power flatness and accuracy	4-9
step attenuator flatness	4-7
automated tests	4-1
installing the software	4-3
running the software	4-5
utilities	4-17
front panel emulation	4-17
calibration constants	4-20
self-test	4-20

HP 8360

C

calibration constants	3-87; <i>see also</i> automated tests
descriptions	3-93
calibration cycle	2-2
checksum verification	3-89

D

delay line discriminator	2-77
--------------------------	------

E

equipment required	1-1
external leveling performance test. <i>see</i> performance tests	

F

FM accuracy performance test. <i>see</i> performance tests	
FM bandwidth performance test. <i>see</i> performance tests	
FM gain adjustment. <i>see</i> adjustments	
fractional-N VCO adjustment. <i>see</i> adjustments	
fractional-N reference and API spurs adjustment. <i>see</i> adjustments	
frequency switching time performance test. <i>see</i> performance tests	

H

harmonics	2-29
-----------	------

I

internal timebase	2-5, 3-3
internal timebase: aging rate performance test. <i>see</i> performance tests	

L

low power SRD bias adjustment. <i>see</i> adjustments	
---	--

M

maximum FM deviation performance test. <i>see</i> performance tests	
maximum leveled power performance test. <i>see</i> performance tests	
modulator offset and gain adjustment. <i>see</i> adjustments	

O

operation verification	2-95
form	2-97
ordering manuals	ii

P

password	3-89
performance tests	2-1
AM accuracy	2-63
AM bandwidth	2-65
AM dynamic range	2-69
deep AM dynamic range	2-71
normal AM dynamic range	2-70
automated. <i>see</i> automated performance tests	
external leveling	2-27
FM accuracy	2-71
FM bandwidth	2-77
DC FM flatness (unlocked)	2-80

find quadrature	2-79
frequency switching time	2-13
CW	2-14
frequency list	2-16
stepped sweep	2-15
internal timebase: aging rate	2-5
maximum FM deviation	2-83
AC FM (at 100 kHz)	2-84
DC FM ($100 \leq \text{Hz}$)	2-83
maximum leveled power	2-23
power accuracy	2-19
power flatness	2-21
pulse modulation video feedthrough	2-57
high band video feedthrough	2-62
low band video feedthrough	2-59
video gain	2-58
pulse performance	2-51
rise and fall times	2-51
pulse leveling accuracy	2-54
single sideband phase noise	2-41
alternate procedure	2-45
spurious signals (harmonic)	2-29
harmonic/subharmonic verification	2-31
spurious signals (line-related)	2-37
spurious signals (non-harmonic)	2-33
fixed spurious signals	2-33
low band spurious signals	2-35
swept frequency accuracy	2-9
power accuracy performance test. <i>see</i> performance tests	
power flatness adjustment. <i>see</i> adjustments; automated adjustments	
power flatness performance test. <i>see</i> performance tests	
power flatness and accuracy performance test. <i>see</i> automated performance tests	
prefix. <i>see</i> serial number	
pulse delay adjustment. <i>see</i> adjustments	
pulse modulation video feedthrough performance test. <i>see</i> performance tests	
pulse performance performance test. <i>see</i> performance tests	
Q	
quadrature. <i>see</i> performance tests, FM bandwidth	

S	
sampler assembly adjustment. <i>see</i> adjustments	
serial number	i
single sideband phase noise performance test. <i>see</i> performance tests	
software, automated tests. <i>see</i> automated tests	
software support request	4-21
spurious signals (harmonic) performance test. <i>see</i> performance tests	
spurious signals (line-related) performance test. <i>see</i> performance tests	
spurious signals (non-harmonic) performance test. <i>see</i> performance tests	
square wave symmetry adjustment. <i>see</i> adjustments	
step attenuator flatness adjustment. <i>see</i> automated adjustments	
step attenuator flatness performance test. <i>see</i> automated performance tests	
subharmonics	2-29
sweep ramp adjustment. <i>see</i> adjustments	
swept frequency accuracy performance test. <i>see</i> performance tests	
SYTM adjustments. <i>see</i> adjustments	
T	
test record	2-89
U	
user flatness correction array	2-21
V	
VCO fixed trim capacitor selection. <i>see</i> adjustments, sampler assembly	
verification. <i>see</i> operation verification	
video feedthrough. <i>see</i> performance tests, pulse modulation video feedthrough	
Y	
YO delay adjustment. <i>see</i> automated adjustments	
YO driver +10V reference adjustment. <i>see</i> adjustments	
YO driver gain and linearity adjustments. <i>see</i> adjustments	
YO loop gain adjustment. <i>see</i> adjustments	